

SERENITY STUDIO 25 – SERENITY STUDIO SERIES

inches (mm)

71 ¼ x 41 ¾ x 25 ½ (1810 x 1060 x 650) • Fax on Demand #1270

SOAKER MODEL #AI25AIR7242CFTO

AIR BATH MODEL #AI25AIR7242CF



FEATURES

- Deep bathing well
- Slip-resistant floor
- Modern styling
- Interior bathing well and exterior can be different colors
- Pre-leveled ABS support base
- Universal drain
- Lucite cast acrylic surface
- Limited lifetime warranty

AIR BATH FEATURES

- Variable speed blower with 20-minute timer
- Air heating system
- Electronic controls with wave and pulse features
- Remote blower kit
- Air channels lined with antimicrobial coating

AQUATIC ADVANTAGE

- National distribution
- 5 manufacturing facilities
- Private fleet
- Centralized customer service
- Field support
- 24-hour fax-on-demand

COLOR & TRIM OPTIONS

Stock	Premium
Almond	Black
Bone	Cashmere
Linen/Biscuit	Mexican Sand
Sterling Silver	Red
White	Sandbar

OPTIONS

- Comfort pillow: Biscuit, Black, White
- Freestanding waste & overflow: Chrome, Oil Rubbed Bronze, Polished Brass, Brushed Nickel, White



SERENITY STUDIO 25

71 1/4 x 41 3/4 x 25 1/2 (1810 x 1060 x 650)
inches (mm)

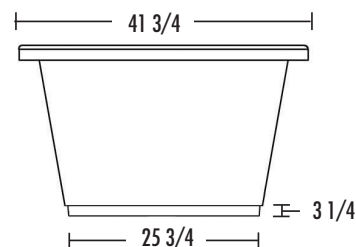
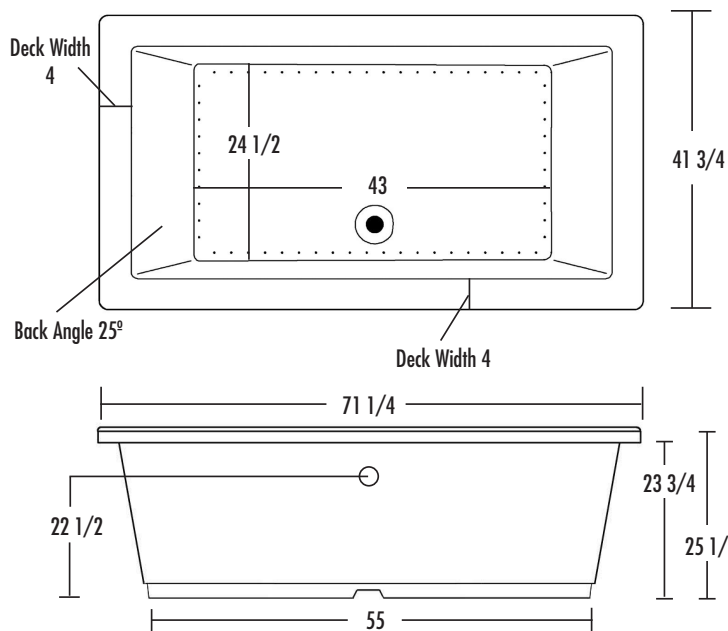

Note: Low profile pedestal prohibits use of decorative drain pipe flange.

FEATURES lbs (kg) Dimensional Tolerance ± 3/8". Dimensions needed for site preparation should be measured from the unit. Aquatic assumes no responsibility for preparatory work.

Type and Model #	Material	Air System	Blower	Pump	Heater	Controls	Drain	Pkg. Wt.
Soaker #AI25AIR7242CFTO	Acrylic	-	-	-	-	-	Universal	275 (125)
Air Bath #AI25AIR7242CF	Acrylic	Channel	Variable speed	-	Inline	Electronic	Universal	305 (139)

DIMENSIONS inches (mm)

Width Overall / Net	Depth Overall / Net	Height Overall / Net	Skirt Height
71 1/4 (1810)	41 3/4 (1060)	25 1/2 (650)	-

SUMP DATA inches (mm)

Capacity to Overflow gal (ltr)	Min. Operating Capacity gal (ltr)
150 (568)	-

PLUMBING DIMENSIONS inches (mm)

A	B
3 1/4 (85)	12 (305)

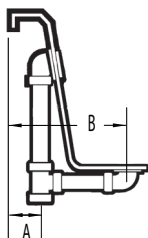

ELECTRICAL DATA

Component	Specification	Requirement
Blower/Heater (Air Bath)	10.5 AMP; 120 V	15 AMP; 120V, separate circuit; Class A GFCI
Pump (Hot Soak)	1/15 HP; 1.3 AMP; 110 V	20 AMP; 110 V, separate circuit; Class A GFCI
Heater (Hot Soak)	1.5 kW; 12.5 AMP; 110 V	

NOTES:

1) Where applicable, utilize cut-out templates packed with unit for deck cutouts.

2) 16 x 20 (405 x 510) minimum access required at pump/blower location(s).

Each Serenity air bath is equipped with an air heating system to raise the temperature of the air entering the bath. This air temperature will be lower than the bathing temperature of the water, but will help reduce rapid decrease in water temperature. In addition, the air coming from the air jets will feel cool against the skin. This system does not heat the water.