



COMMERCIAL PLASTIC SEATS

MODEL 2055CT

- ROUND SEAT, OPEN FRONT LESS COVER
- SOLID PLASTIC
- DURAGUARD® ANTIMICROBIAL AGENT
- STA-TITE®, COMMERCIAL FASTENING SYSTEM™

DuraGuard®
ANTIMICROBIAL

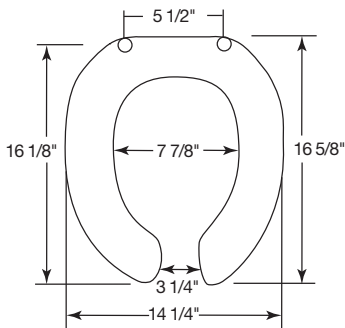

Ring thickness is 13/16"
Ring thickness including the bumper is 1"
Height of the seat is 2-1/4"

Seats shall be No. _____ as manufactured by Church Seats. Seats shall contain DuraGuard®, an antimicrobial agent. Seats shall be heavy weight and injection molded of solid plastic. Seats shall be open front less cover for round bowl and feature large molded-in bumpers. Seats shall have STA-TITE®, Commercial Fastening System™, featuring concealed check hinges with 300 Series stainless steel posts and pintles that stop seat 11 degrees beyond vertical. Color to be white.

Hinges shall be 2055CT / 2055SSCT.
(Circle model based on description below.)

2055CT Concealed check hinge stops seat 11° beyond vertical.

2055SSCT Self-sustaining, concealed stainless steel check hinge holds seat in any raised position up to 11° beyond vertical.



STA-TITE®

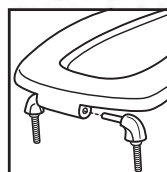

Assemble hinges.

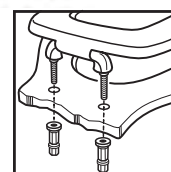

Finger-tighten fastening nuts.

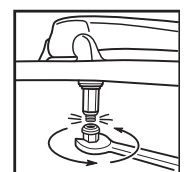

Using wrench, tighten until lower portion shears off.