



COMMERCIAL PLASTIC SEATS

MODEL 3155CT

- ELONGATED SEAT, OPEN FRONT LESS COVER
- SOLID PLASTIC
- DURAGUARD® ANTIMICROBIAL AGENT
- STA-TITE®, COMMERCIAL FASTENING SYSTEM™

DuraGuard®
ANTIMICROBIAL

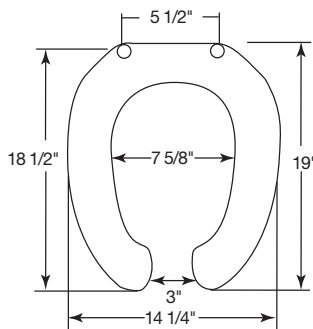

Ring thickness is 1"
Ring thickness including the bumper is 1-3/16"
Height of the seat is 2-5/8"

Seats shall be No. _____ as manufactured by Church Seats. Seats shall contain DuraGuard®, an antimicrobial agent. Seats shall be extra heavy weight and injection molded of solid plastic. Seats shall be open front less cover for elongated bowl and feature large molded-in bumpers. Seats shall have STA-TITE®, Commercial Fastening System™, featuring concealed check hinges with 300 Series stainless steel posts and pintles that stop seat 11 degrees beyond vertical. Color to be white.

Hinges shall be 3155CT / 3155SSCT.
(Circle model based on description below.)

3155CT Concealed check hinge stops seat 11° beyond vertical.

3155SSCT Self-sustaining, concealed stainless steel check hinge holds seat in any raised position up to 11° beyond vertical.



STA-TITE®

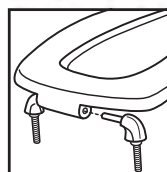

Assemble hinges.

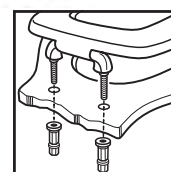

Finger-tighten fastening nuts.

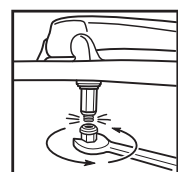

Using wrench, tighten until lower portion shears off.