

**K09-2GL, K09-2SPGL
and K09-3GL
COLOR-CODED CRIMPING TOOLS**

99922045

IM 1289 REV 3 3/12

© 2012 Greenlee Textron Inc.

	⚠ WARNING A person who has not read and does not understand all operating instructions is not qualified to operate this tool. Failure to read and understand safety instructions may result in injury or death.
--	--

	⚠ WARNING Electrical shock hazard: This tool is not insulated. Contact with live circuits can result in severe injury or death.
--	--

⚠ WARNING	<ul style="list-style-type: none"> Do not use on aluminum connectors or aluminum wire. Use proper die, connector and wire combinations. <p>Mismatched components can result in an incomplete crimp. An incomplete crimp may have high electrical resistance or may separate, resulting in a fire, severe injury or death.</p>
------------------	---

	⚠ WARNING Wear eye protection when using this tool. Failure to wear eye protection can result in serious eye injury from flying debris.
--	--

⚠ CAUTION	This tool is intended for two-handed operation. Maintain a firm grip on both handles during operation. Using this tool in any other manner can result in injury or damage to the tool.
------------------	--

	⚠ CAUTION Keep hands away from closing dies and other moving parts. Failure to observe this precaution can result in injury.
--	--

	⚠ ADVERTENCIA La persona que no haya leído o no comprenda estas instrucciones de operación no estará calificada para manejar esta herramienta. De no leerse y comprenderse estas instrucciones sobre seguridad podrían sufrirse lesiones o incluso la muerte.
--	--

	⚠ ADVERTENCIA Peligro de electrocución: Esta herramienta no está aislada. El contacto con circuitos activados puede ocasionar graves lesiones o incluso la muerte.
--	---

⚠ ADVERTENCIA	<ul style="list-style-type: none"> No lo utilice con conectores ni cables de aluminio. Utilice la combinación adecuada de casquillos, conectores y cables. <p>No utilizar los componentes correspondientes puede dar como resultado un engarzado incompleto o bien, provocar un incendio, graves lesiones o incluso la muerte, si un empalme se separa o presenta una resistencia muy alta a la corriente eléctrica.</p>
----------------------	--

	⚠ ADVERTENCIA Al manejar esta herramienta utilice protectores para los ojos; de lo contrario podría sufrir graves lesiones oculares ocasionadas si los restos de cable llegaran a saltar.
--	---

⚠ ATENCIÓN	Esta herramienta ha sido diseñada para manejarse con las dos manos. Sujete firmemente ambas manijas mientras la herramienta está en funcionamiento. Utilizarla de otra forma podría ocasionar lesiones o dañar el engarzador.
-------------------	---

	⚠ ATENCIÓN Mantenga las manos lejos de los casquillos mientras se cierran y de otras partes en movimiento; de lo contrario podría sufrir lesiones.
--	--

	⚠ AVERTISSEMENT Une personne qui n'a pas lu et ne comprend pas toutes les instructions d'utilisation n'est pas qualifiée pour utiliser cet outil. Négliger de lire et de comprendre les instructions de sécurité peut résulter en blessures ou en mort.
--	--

	⚠ AVERTISSEMENT Risques de choc électrique : Cet outil n'est pas isolé. Le contact avec des circuits sous tension peut causer des blessures graves ou la mort.
--	---

⚠ AVERTISSEMENT	<ul style="list-style-type: none"> Ne pas utiliser avec des connecteurs ou des fils en aluminium. Utiliser les bonnes combinaisons de matrices, de connecteurs et de câbles. <p>Des éléments mal assortis peuvent résulter en un sertissage incomplet. Un sertissage incomplet peut avoir une haute résistance électrique ou peut se séparer, le résultat pouvant être un incendie, des blessures graves ou même la mort.</p>
------------------------	---

	⚠ AVERTISSEMENT Porter une protection des yeux pendant l'utilisation de cet outil. Négliger de se protéger les yeux peut résulter en de sérieuses blessures aux yeux causées par la projection de débris.
--	--

⚠ ATTENTION	Cet outil est prévu pour être manié avec les deux mains. Pendant son utilisation, maintenir une forte prise sur les deux branches. Utiliser cet outil de toute autre façon peut résulter en blessures ou en dommages matériels.
--------------------	---

	⚠ ATTENTION Garder les mains à l'écart de la fermeture des matrices et de toutes autres parties mobiles. Négliger cette précaution peut résulter en blessures.
--	--

Range

- K09-2GL, K09-2SPGL: 8 AWG – 4/0 AWG
- K09-3GL: 3/0 AWG – 400 kcmil

Crimping Instructions

1. Remove the cable insulation according to the instructions supplied with each lug or splice. Do not cut or nick the individual strands.
2. Open the tool to its widest point and depress the die post mechanism.
3. Select the proper die setting by rotating the die, matching the cable size and colored dot at the top of the die to the cable size and colored bands of the connector. Release the post so that it returns to its original position. Repeat this process for the opposite die, making sure both dies match.
4. Insert the appropriate connector between the color-coded bands closest to the tongue for lugs, between the center marks for splices (see Figure 1).

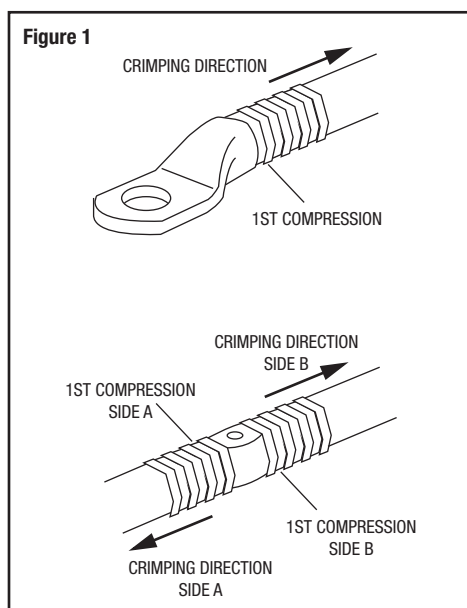

5. Close the tool completely. Make sure the crimp remains parallel to the color-coded bands.
Note: A ratcheting tool can not be opened until the crimp is complete.
Repeat this procedure for the recommended number of crimps as described in the chart on the following page. Crimp away from the first crimp (see Figure 1).

Maintenance

1. Clean the tool often and store in a dry location.
2. Oil the moving parts, including rotating die selectors, frequently.

Register this product at www.greenlee.com

Rango

- K09-2GL, K09-2SPGL: 8 AWG – 4/0 AWG
- K09-3GL: 3/0 AWG – 400 kcmil

Instrucciones para realizar el engarzado

1. Pele el cable tal como se indica en las instrucciones incluidas con cada orejeta o empalmador. No corte ni melle los hilos del cable.
2. Abra la herramienta completamente y desactive el mecanismo colocador de casquillos.
3. Seleccione la posición correcta del casquillo girándolo, y haciendo que el tamaño del cable y el punto de color en su parte superior coincida con el tamaño del cable y las rayas de color del conector. Suelte el colocador de modo que vuelva a su posición original. Repita este procedimiento para el otro casquillo asegurándose de que ambos coincidan.
4. Inserte el conector apropiado entre las bandas codificadas por color más próximas a la lengüeta para orejetas, entre las marcas centrales para los empalmes. (Véase la figura 1).

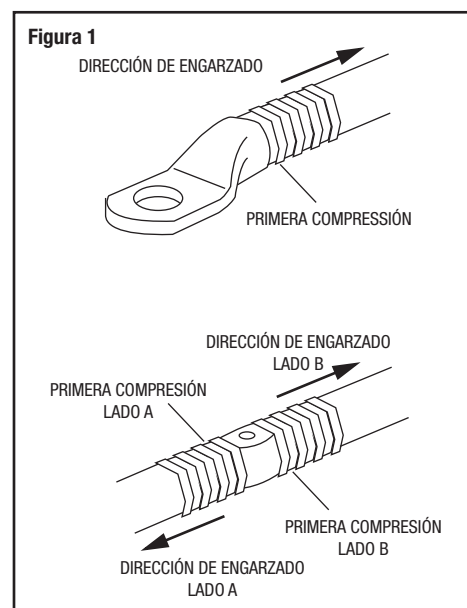

5. Cierre completamente la herramienta. Asegúrese de que el engarzado se mantenga paralelo a las bandas codificadas por color.
Nota: Nunca deberá abrirse una herramienta de trinquete hasta que no se haya completado el engarzado.
Repita este procedimiento para el número recomendado de engarzados tal como se describe en el diagrama de la siguiente página. Comience a partir del primer engarzado (Véase la figura 1).

Mantenimiento

1. Limpie con frecuencia la herramienta y guárdela en un lugar seco.
2. Aceite frecuentemente las partes móviles incluyendo los selectores giratorios de casquillo.

Registre este producto en www.greenlee.com

Capacité

- K09-2GL, K09-2SPGL: 8 AWG – 4/0 AWG
- K09-3GL: 3/0 AWG – 400 kcmil

Instructions de sertissage

1. Dénuder le câble conformément aux instructions fournies avec chaque cosse ou épissure. Ne pas couper ni entailler les torons individuels.
2. Ouvrir l'outil à son point le plus large et appuyer sur le mécanisme de rotation de la matrice.
3. Choisir le réglage de matrice correct en tournant la matrice, accordant le calibre du câble et le point de couleur sur le dessus de la matrice avec la dimension du câble et les bandes de couleur du connecteur. Relâcher le mécanisme de la matrice pour qu'il revienne à sa position d'origine. Répéter le même processus pour la matrice opposée, en s'assurant que les deux matrices s'accordent.
4. Insérer le connecteur approprié entre les bandes codées couleur les plus proches de la patte pour cosse, entre les marques centrales pour épissures (Voir Figure 1).

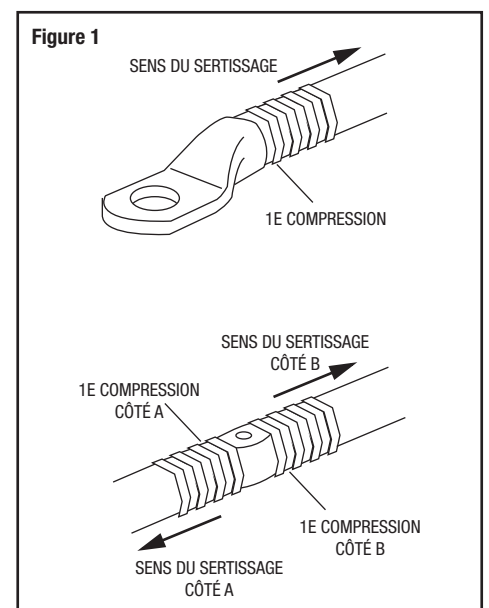

5. Fermer l'outil complètement. S'assurer que le sertissage est parallèle aux bandes du codage couleur.
Remarque : Un outil à cliquet ne peut pas être ouvert avant que le sertissage soit complété.
Répéter ce processus pour le nombre de sertissage recommandé comme décrit sur le tableau de la page suivante. Sertir en s'éloignant du premier sertissage (Voir Figure 1).

Entretien

1. Nettoyer souvent l'outil et le ranger dans un endroit sec.
2. Huiler fréquemment les pièces mobiles, y compris le sélecteur rotatif de matrices.

Enregistrez votre produit en ligne, www.greenlee.com

K09-2GL, K09-2SPGL and K09-3GL

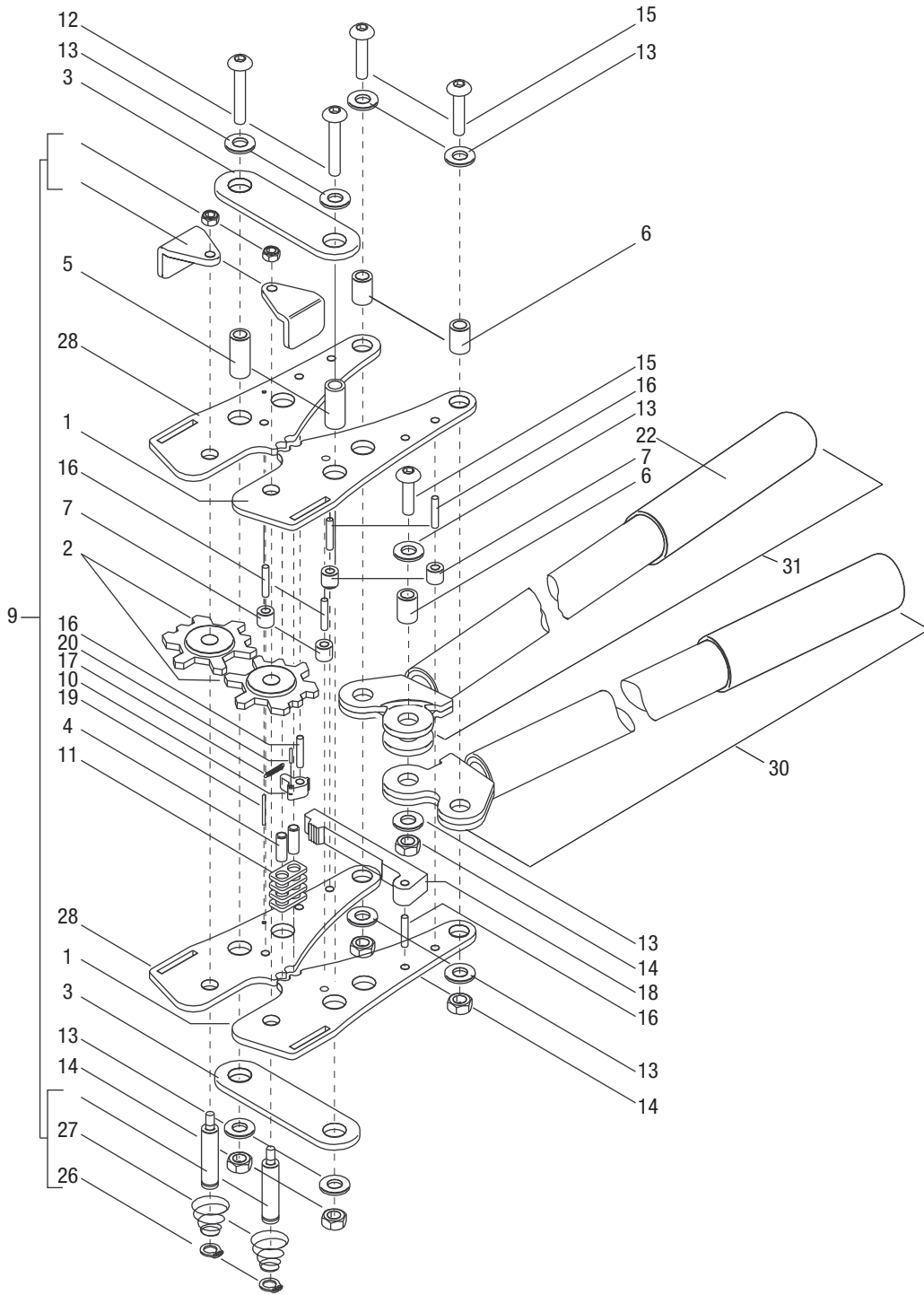

Key	Part No.	Description	Qty
1	50029118	Crimp Head Plate (K09-2GL, K09-3GL)	4
	50029118	Crimp Head Plate (K09-2SPGL)	2
2	50029126	Die Set (K09-2GL, K09-2SPGL).....	1
	50029134	Die Set (K09-3GL).....	1
3	50029142	Crimp Jaw Strap.....	2
4	50029150	Pivot Bushing.....	2
5	50029169	Bushing (8.1 x 14 x 30)	2
6	50029231	Bushings (8.1 x 12 x 20)	3
7	50029240	Inner Bushing.....	4
9	50029274	Die Axle Assembly	2
10	50029290	Ratchet Pawl.....	1
11	50031074	Pivot Bushing Retainer	4
12	50031104	Allen Bolt 8x42 mm.....	2
13	50031112	Washer, Burnished.....	10
14	50031120	Locknut, 8 mm.....	5
15	50031139	Allen Bolt, 8 x 32 mm.....	3
16	50031147	Retainer Pin, 5 x 20 mm	4
17	50034065	Spring	1
18	50034081	Rack.....	1
19	50034090	Pin, 2 x 20.....	1
20	50034103	Pin, 2 x 10.....	1
22	50034138	Grip.....	2
26	50034308	Retaining Ring.....	2
27	50034421	Return Spring.....	2
28	50034707	Crimp Plate (K09-2SPGL).....	2
29	50034944	Ratchet Assembly (K09-2SPGL) (includes 10, 17, 18, 19 and 20).....	1

Greenlee K09-2 Type Crimping Tools Tool Range: 8-4/0 AWG

This tool is cUL and UL classified for use with the following connector brands:

CONNECTOR TYPE	BARREL TYPE	ANDERSON	BLACKBURN®	BURNDY	ILSCO	PANDUIT	T&B	PENN-UNION	NUMBER OF CRIMPS*
Copper Splice	Short	VHSS	CSP	YS-L	CT	SCSS/SCS	54504-54512	BCU	A
	Long	VHS	CU	YS	CTL	SCL/SCH	54804-54812	BBCU	B
Copper Lugs	Short	VHCS	CTL-2/CTL	YA/YA-L/YA-2L YA-2LN/YA-L-TC/YA-L-2TC	CSW CRA/CRB	LCAS/LCA LCD	54104-54112 54204-54212	BLU	A
	Long	VHCL	CTL-L/LCN	YA-2N	CLN/CLW CRA-L/CRB-L CRA-2L/CRB-2L	LCB/LCC	54930BE-54970BE 54850BE-54866BE	BBLU	B

Greenlee K09-3 Type Crimping Tools Tool Range: 3/0 AWG-400 kcmil

This tool is cUL and UL classified for use with the following connector brands:

CONNECTOR TYPE	BARREL TYPE	ANDERSON	BLACKBURN®	BURNDY	ILSCO	PANDUIT	T&B	PENN-UNION	NUMBER OF CRIMPS*
Copper Splice	Short	VHSS	CSP	YS-L	CT	SCSS/SCS	54511-54516	BCU	A
	Long	VHS	CU	YS	CTL	SCL/SCH	54811-54816	BBCU	B
Copper Lugs	Short	VHCS	CTL-2/CTL	YA/YA-L/YA-2L YA-2LN/YA-L-TC/YA-L-2TC	CSW CRA/CRB	LCAS/LCA LCD	54111-54116 54211-54216	BLU	A
	Long	VHCL	CTL-L/LCN	YA-2N	CLN/CLW CRA-L/CRB-L CRA-2L/CRB-2L	LCB/LCC	54965BE-54916BE 54864BE-54874BE	BBLU	B



*Use the number of crimps listed in the last column instead of the number provided with the connector:

A: 8 AWG-1/0 AWG:	1 crimp	B: 8 AWG-1/0 AWG:	2 crimps
2/0 AWG-400 kcmil:	2 crimps	2/0 AWG-3/0 AWG:	3 crimps
		4/0 AWG-400 kcmil:	4 crimps

BLACKBURN is a registered trademark of Thomas & Betts.



4455 Boeing Drive • Rockford, IL 61109-2988 • USA • 815-397-7070
An ISO 9001 Company • Greenlee Textron Inc. is a subsidiary of Textron Inc.
www.greenlee.com

USA Tel: 800-435-0786 Fax: 800-451-2632

Canada Tel: 800-435-0786 Fax: 800-524-2853

International Tel: +1-815-397-7070 Fax: +1-815-397-9247