

LM(D)E, LP(D)E, TPE(D), NKE, NBE, CLME, 1~ and 3~

- Ⓜ GB Installation and operating instructions
- Ⓜ D Montage- und Betriebsanleitung
- Ⓜ F Notice d'installation et d'entretien
- Ⓜ I Istruzioni di installazione e funzionamento
- Ⓜ E Instrucciones de instalación y funcionamiento
- Ⓜ P Instruções de instalação e funcionamento
- Ⓜ GR Οδηγίες εγκατάστασης και λειτουργίας
- Ⓜ NL Installatie- en bedieningsinstructies
- Ⓜ S Monterings- och driftsinstruktion
- Ⓜ SF Asennus- ja käyttöohjeet
- Ⓜ DK Monterings- og driftsinstruktion



Declaration of Conformity

We **GRUNDFOS** declare under our sole responsibility that the products **LM(D)E, LP(D)E, TPE(D), NKE, NBE** and **CLME**, to which this declaration relates, are in conformity with the Council Directives on the approximation of the laws of the EEC Member States relating to:

- Machinery (98/37/EEC).
Standard used: EN 292.
- Electromagnetic compatibility (89/336/EEC).
Standard used: EN 61 800-3.
- Electrical equipment designed for use within certain voltage limits (73/23/EEC).
Standards used: EN 60 335-1 and EN 60 335-2-51.

Konformitätserklärung

Wir **GRUNDFOS** erklären in alleiniger Verantwortung, daß die Produkte **LM(D)E, LP(D)E, TPE(D), NKE, NBE** und **CLME**, auf die sich diese Erklärung bezieht, mit den folgenden Richtlinien des Rates zur Angleichung der Rechtsvorschriften der EG-Mitgliedstaaten übereinstimmen:

- Maschinen (98/37/EWG).
Norm, die verwendet wurde: EN 292.
- Elektromagnetische Verträglichkeit (89/336/EWG).
Norm, die verwendet wurde: EN 61 800-3.
- Elektrische Betriebsmittel zur Verwendung innerhalb bestimmter Spannungsgrenzen (73/23/EWG).
Normen, die verwendet wurden: EN 60 335-1 und EN 60 335-2-51.

Déclaration de Conformité

Nous **GRUNDFOS** déclarons sous notre seule responsabilité que les produits **LM(D)E, LP(D)E, TPE(D), NKE, NBE** et **CLME** auxquels se réfère cette déclaration sont conformes aux Directives du Conseil concernant le rapprochement des législations des Etats membres CEE relatives à

- Machines (98/37/CEE).
Standard utilisé: EN 292.
- Compatibilité électromagnétique (89/336/CEE).
Standard utilisé: EN 61 800-3.
- Matériel électrique destiné à employer dans certaines limites de tension (73/23/CEE).
Standards utilisés: EN 60 335-1 et EN 60 335-2-51.

Dichiarazione di Conformità

Noi **GRUNDFOS** dichiariamo sotto la nostra esclusiva responsabilità che i prodotti **LM(D)E, LP(D)E, TPE(D), NKE, NBE** e **CLME**, ai quali questa dichiarazione si riferisce, sono conformi alle direttive del Consiglio, concernenti il ravvicinamento delle legislazioni degli Stati membri CEE relativi a

- Macchine (98/37/CEE).
Standard usato: EN 292.
- Compatibilità elettromagnetica (89/336/CEE).
Standard usato: EN 61 800-3.
- Materiale elettrico destinato ad essere utilizzato entro certi limiti di tensione (73/23/CEE).
Standard usati: EN 60 335-1 e EN 60 335-2-51.

Declaración de Conformidad

Nosotros **GRUNDFOS** declaramos bajo nuestra única responsabilidad que los productos **LM(D)E, LP(D)E, TPE(D), NKE, NBE** y **CLME** a los cuales se refiere esta declaración son conformes con las Directivas del Consejo relativas a la aproximación de las legislaciones de los Estados Miembros de la CEE sobre

- Máquinas (98/37/CEE).
Norma aplicada: EN 292.
- Compatibilidad electromagnética (89/336/CEE).
Norma aplicada: EN 61 800-3.
- Material eléctrico destinado a utilizarse con determinados límites de tensión (73/23/CEE).
Normas aplicadas: EN 60 335-1 y EN 60 335-2-51.

Declaração de conformidade

Nós **GRUNDFOS** declaramos sob nossa responsabilidade que os produtos **LM(D)E, LP(D)E, TPE(D), NKE, NBE** e **CLME**, aos quais esta declaração se refere, estão em conformidade com as Directivas Comunitárias com aproximação das leis dos estados membros da CEE para:

- Máquinas (98/37/CEE).
Norma usada: EN 292.
- Compatibilidades Electromagnéticas (89/336/CEE).
Norma usada: EN 61 800-3.
- Equipamento Eléctrico desenhado para uso de certos limites de tensão (73/23/CEE).
Norma usada: EN 60 335-1 e EN 60 335-2-51.

Δήλωση Συμμόρφωσης

Εμείς η **GRUNDFOS** δηλώνουμε με αποκλειστικά δική μας ευθύνη ότι τα προϊόντα **LM(D)E, LP(D)E, TPE(D), NKE, NBE** και **CLME** συμμορφώνονται με την Οδηγία του Συμβουλίου επί της σύγκλισης των νόμων των Κρατών Μελών της Ευρωπαϊκής Ένωσης σε σχέση με τα:

- Μηχανήματα (98/37/EEC).
Πρότυπο που χρησιμοποιήθηκε: EN 292.
- Ηλεκτρομαγνητική συμβατότητα (89/336/EEC).
Πρότυπο που χρησιμοποιήθηκε: EN 61 800-3.
- Ηλεκτρικές συσκευές σχεδιασμένες για χρήση εντός ορισμένων ορίων ηλεκτρικής τάσης (73/23/EEC).
Πρότυπα που χρησιμοποιήθηκαν: EN 60 335-1 και EN 60 335-2-51.

Overeenkomstigheidsverklaring

Wij **GRUNDFOS** verklaren geheel onder eigen verantwoordelijkheid dat de producten **LM(D)E, LP(D)E, TPE(D), NKE, NBE** en **CLME** waarop deze verklaring betrekking heeft in overeenstemming zijn met de Richtlijnen van de Raad inzake de onderlinge aanpassing van de wetgevingen van de Lid-Staten betreffende

- Machines (98/37/EEG).
Norm: EN 292.
- Elektromagnetische compatibiliteit (89/336/EEG).
Norm: EN 61 800-3.
- Elektrisch materiaal bestemd voor gebruik binnen bepaalde spanningsgrenzen (73/23/EEG).
Normen: EN 60 335-1 en EN 60 335-2-51.

Försäkran om överensstämmelse

Vi **GRUNDFOS** försäkrar under ansvar, att produkterna **LM(D)E, LP(D)E, TPE(D), NKE, NBE** och **CLME**, som omfattas av denna försäkran, är i överensstämmelse med Rådets Direktiv om inbördes närmande till EU-medlemsstaternas lagstiftning, avseende

- Maskinell utrustning (98/37/EC).
Använd standard: EN 292.
- Elektromagnetisk kompatibilitet (89/336/EC).
Använd standard: EN 61 800-3.
- Elektrisk material avsedd för användning inom vissa spänningsgränser (73/23/EC).
Använda standarder: EN 60 335-1 och EN 60 335-2-51.

Vastaavuusvakuutus

Me **GRUNDFOS** vakuutamme yksin vastuullisesti, että tuotteet **LM(D)E, LP(D)E, TPE(D), NKE, NBE** ja **CLME**, jota tämä vakuutus koskee, noudattavat direktiivejä jotka käsittelevät EY:n jäsenvaltioiden koneellisia laitteita koskevien lakien yhdenmukaisuutta seur.:

- Koneet (98/37/EY).
Käytetty standardi: EN 292.
- Elektromagneettinen vastaavuus (89/336/EY).
Käytetty standardi: EN 61 800-3.
- Määrättyjen jänniterajoitusten puitteissa käytettävät sähköiset laitteet (73/23/EY).
Käytetyt standardit: EN 60 335-1 ja EN 60 335-2-51.

Overensstemmelseserklæring

Vi **GRUNDFOS** erklærer under ansvar, at produkterne **LM(D)E, LP(D)E, TPE(D), NKE, NBE** og **CLME**, som denne erklæring omhandler, er i overensstemmelse med Rådets direktiver om indbyrdes tilnærmelse til EF medlemsstaternes lovgivning om:

- Maskiner (98/37/EEC).
Anvendt standard: EN 292.
- Elektromagnetisk kompatibilitet (89/336/EEC).
Anvendt standard: EN 61 800-3.
- Elektrisk materiel bestemt til anvendelse inden for visse spændingsgrænser (73/23/EEC).
Anvendte standarder: EN 60 335-1 og EN 60 335-2-51.

Bjerringbro, 1st January 2002

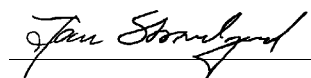

Jan Strandgaard
Technical Manager

LM(D)E, LP(D)E, TPE(D), NKE, NBE, CLME, 1~ and 3~

Installation and operating instructions	Page	4	GB
Montage- und Betriebsanleitung	Seite	21	D
Notice d'installation et d'entretien	Page	39	F
Istruzioni di installazione e funzionamento	Pag.	56	I
Instrucciones de instalación y funcionamiento	Pág.	73	E
Instruções de instalação e funcionamento	Pág.	90	P
Οδηγίες εγκατάστασης και λειτουργίας	Σελίδα	107	GR
Installatie- en bedieningsinstructies	Pag.	124	NL
Monterings- och driftsinstruktion	Sida	141	S
Asennus- ja käyttöohjeet	Sivu	158	SF
Monterings- og driftsinstruktion	Side	175	DK

CONTENTS

	Page		Page
1. General	4	12. Technical data – single-phase pumps	19
1.1 Twin-head pumps	4	12.1 Supply voltage	19
2. Installation	4	12.2 Leakage current	19
2.1 Electrical connection – single-phase pumps	5	12.3 Inputs/output	19
2.1.1 Mains switch	5	13. Technical data – three-phase pumps	19
2.1.2 Protection against electric shock – indirect contact	5	13.1 Supply voltage	19
2.1.3 Additional protection	5	13.2 Leakage current	19
2.1.4 Motor protection	5	13.3 Inputs/output	19
2.1.5 Overvoltage protection	5	13.4 Other technical data	20
2.1.6 Supply voltage	5	14. Disposal	20
2.1.7 Start/stop of pump	5		
2.2 Electrical connection – three-phase pumps	6		
2.2.1 Mains switch	6		
2.2.2 Protection against electric shock – indirect contact	6		
2.2.3 Additional protection	6		
2.2.4 Motor protection	6		
2.2.5 Overvoltage protection	6		
2.2.6 Supply voltage	6		
2.2.7 Start/stop of pump	6		
2.3 Other connections – single-phase pumps	7		
2.4 Other connections – single-phase TPED pumps	7		
2.5 Other connections – three-phase pumps	8		
2.6 Signal cables	8		
3. Setting the pump	9		
3.1 Control modes	9		
3.2 Operating modes	9		
3.2.1 Additional operating modes – single-phase TPED pumps	9		
3.3 Factory setting	10		
3.4 Factory setting – single-phase TPED pumps	10		
4. Setting by means of control panel	10		
4.1 Setpoint setting	10		
4.2 Setting to max. curve duty	11		
4.3 Setting to min. curve duty	11		
4.4 Start/stop of pump	11		
5. Setting by means of R100	12		
5.1 Menu OPERATION	13		
5.1.1 Setpoint setting	13		
5.1.2 Setting of operating mode	13		
5.1.3 Fault indications	13		
5.1.4 Alarm log	13		
5.2 Menu STATUS	13		
5.2.1 Display of actual setpoint	13		
5.2.2 Display of operating mode	13		
5.2.3 Display of actual value	13		
5.2.4 Display of actual speed	14		
5.2.5 Display of input power and power consumption	14		
5.2.6 Display of operating hours	14		
5.3 Menu INSTALLATION	14		
5.3.1 Selection of control mode	14		
5.3.2 Setting of controller	14		
5.3.3 Selection of external setpoint signal	15		
5.3.4 Selection of fault, operating or ready signal relay	15		
5.3.5 Blocking of the buttons on the pump	15		
5.3.6 Allocation of pump number	15		
5.3.7 Selection of function for digital input	15		
5.3.8 Setting of sensor	15		
5.3.9 Setting of min. and max. curves	15		
6. External forced-control signals	16		
6.1 Start/stop input	16		
6.2 Digital input	16		
7. External setpoint signal	16		
8. Bus signal	16		
9. Priority of settings	17		
10. Indicator lights and signal relay	18		
11. Megging	18		



Before beginning installation procedures, these installation and operating instructions should be studied carefully. **Furthermore, the enclosed installation and operating instructions for the standard pump should be studied carefully.** The installation and operation should also be in accordance with local regulations and accepted codes of good practice.

1. General

GRUNDFOS E-pumps are pumps fitted with frequency-controlled standard motors for single-phase or three-phase mains connection.

The pumps have a built-in PI controller and can be connected to an external sensor enabling control of for instance pressure, differential pressure, temperature, differential temperature or flow in the system in which the pumps are installed. The pumps can be set to uncontrolled operation, i.e. the pump performance can be set according to the demand.

The pumps are typically used as circulator pumps in large heating or cooling water systems with variable demands.

The desired value (setpoint), e.g. the desired differential pressure if a differential pressure sensor has been installed, can be set directly on the pump control panel, via an input for external setpoint signal or by means of the GRUNDFOS wireless remote control R100.

All other settings are made by means of the R100.

Important parameters such as actual value of control parameter, power consumption, etc. can be read via the R100.

The pump incorporates inputs for external potential-free contacts for start/stop and digital function. The digital function enables external setting of max. curve or min. curve.

The pump incorporates an output for a potential-free fault, operating or ready signal.

Furthermore, the pump has an input for bus communication. Via the bus communication input, the pump can be controlled and monitored by a building management system or another external control system.

1.1 Twin-head pumps

Single-phase twin-head pumps do not require any external controller.

Three-phase twin-head pumps usually require an external controller. The GRUNDFOS Delta Control 2000 ME has been developed for this application.

For further details about the setting and connection of three-phase twin-head pumps, see installation and operating instructions for the Delta Control 2000 ME.

2. Installation

To ensure cooling of motor and electronics, the following must be observed:

- Place the pump in such a way that sufficient cooling is ensured.
- The temperature of the cooling air must not exceed 40°C.
- Motor cooling fins and fan blades must be kept clean.

When installed outdoors, the motor must be provided with a suitable cover to avoid condensation on the electronic components, fig. 1.

Fig. 1

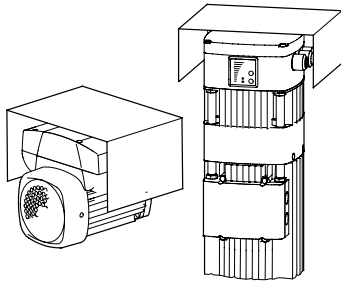

For further installation, see installation and operating instructions for the standard pump.

2.1 Electrical connection – single-phase pumps

Note: The user or the installer is responsible for the installation of the correct earthing and protection according to valid national and local standards. All operations must be carried out by a qualified electrician.



Never make any connections in the pump terminal box unless the electricity supply has been switched off for at least 5 minutes.

2.1.1 Mains switch

The pump must be connected to an external all-pole mains switch with a contact separation of at least 3 mm in each pole according to IEC 364.

2.1.2 Protection against electric shock – indirect contact



The pump must be earthed and protected against indirect contact in accordance with national regulations.

Protective earth conductors must always have a yellow/green (PE) or yellow/green/blue (PEN) colour marking.

2.1.3 Additional protection

If the pump is connected to an electric installation where an earth leakage circuit breaker is used as additional protection, this circuit breaker must be marked with the following symbol:



ELCB

Note: When an earth leakage circuit breaker is selected, the total leakage current of all the electrical equipment in the installation must be taken into account.

The leakage current of the pump can be found in section 12.2 *Leakage current*.

2.1.4 Motor protection

The pump requires no external motor protection. The motor incorporates thermal protection against slow overloading and blocking (IEC 34-11: TP 211).

2.1.5 Overvoltage protection

The pump is overvoltage-protected through built-in varistors between phase-neutral and phase-earth.

2.1.6 Supply voltage

1 x 200-240 V ±10%, 50/60 Hz, PE.

The supply voltage and frequency are marked on the pump nameplate. Please make sure that the motor is suitable for the electricity supply on which it will be used.

The wires in the pump terminal box must be as short as possible. Excepted from this is the protective earth conductor which must be so long that it is the last one to be disconnected in case the cable is inadvertently pulled out of the cable entry.

Figure 2 shows an example of a mains-connected pump with mains switch, back-up fuses and additional protection.

Fig. 2

MGE 71 and MGE 80

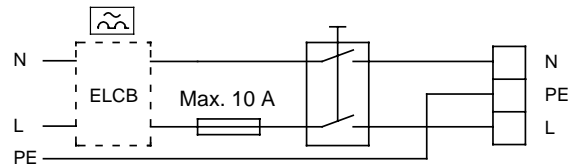

Actual mains connection is shown in figs. 3 and 4.

Fig. 3

MGE 71 and MGE 80

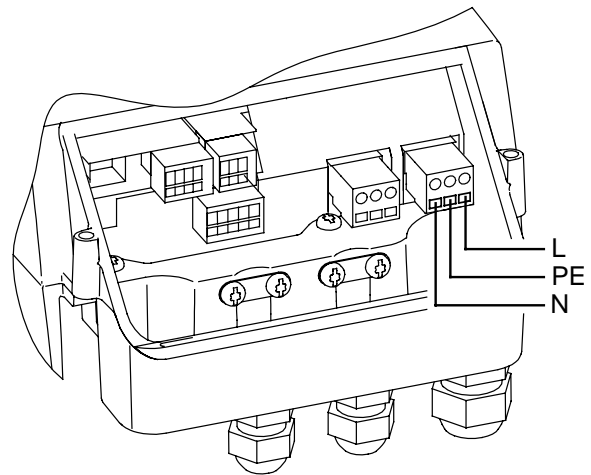
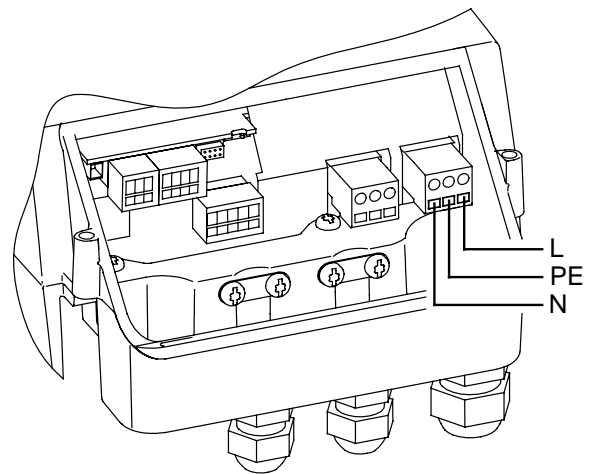

Fig. 4

TPED - MGE 71 and MGE 80



2.1.7 Start/stop of pump

The number of starts and stops via the mains voltage must not exceed 4 times per hour.

When the pump is switched on via the mains, it will start after approx. 5 seconds.

If a higher number of starts and stops is desired, the input for external start/stop must be used when starting/stopping the pump. When the pump is started/stopped via an external on/off switch, it will start immediately.

TM02 0789 0101

GB

TM02 0827 4702

TM02 5990 4702

2.2 Electrical connection – three-phase pumps

Note: The user or the installer is responsible for the installation of the correct earthing and protection according to valid national and local standards. All operations must be carried out by a qualified electrician.



Never make any connections in the pump terminal box unless the electricity supply has been switched off for at least 5 minutes.

2.2.1 Mains switch

The pump must be connected to an external all-pole mains switch with a contact separation of at least 3 mm in each pole according to IEC 364.

2.2.2 Protection against electric shock – indirect contact



The pump must be earthed and protected against indirect contact in accordance with national regulations.

Protective earth conductors must always have a yellow/green (PE) or yellow/green/blue (PEN) colour marking.

Note: As the leakage current of 4 kW to 7.5 kW motors is > 3.5 mA, these motors must be connected to especially reliable/sturdy earth connections.

The leakage current of the individual motor size can be found in section 13.2 *Leakage current*.

EN 50 178 and BS 7671 specify the following:

Leakage current > 3.5 mA:

The pump must be stationary and installed permanently. Furthermore, the pump must be connected permanently to the electricity supply or may be connected via an industrial type of plug (CEE). The plug must comply with EN 60 309 or IEC 309.

- The earth connection must be carried out as duplicate conductors.

2.2.3 Additional protection

If the pump is connected to an electric installation where an earth leakage circuit breaker is used as additional protection, this circuit breaker must be of the type:

- which is suitable for handling leakage currents and cutting-in with short pulse-shaped leakage.
- which trips out when alternating fault currents and fault currents with DC content, i.e. pulsating DC and smooth DC fault currents, occur.

For these pumps an earth leakage circuit breaker **type B** must be used.

This circuit breaker must be marked with the following symbols:

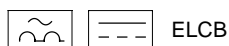

Note: When an earth leakage circuit breaker is selected, the total leakage current of all the electrical equipment in the installation must be taken into account.

The leakage current of the pump can be found in section 13.2 *Leakage current*.

2.2.4 Motor protection

The pump requires no external motor protection. The motor incorporates thermal protection against slow overloading and blocking (IEC 34-11: TP 211).

2.2.5 Overvoltage protection

The pump is overvoltage-protected through built-in varistors between the phases and between phases and earth.

2.2.6 Supply voltage

3 x 380-415 V ±10%, 50/60 Hz, PE.

The supply voltage and frequency are marked on the pump nameplate. Please make sure that the motor is suitable for the electricity supply on which it will be used.

The wires in the pump terminal box must be as short as possible. Excepted from this is the protective earth conductor which must be so long that it is the last one to be disconnected in case the cable is inadvertently pulled out of the cable entry.

Figure 5 shows an example of a mains-connected pump with mains switch, back-up fuses and additional protection.

Fig. 5

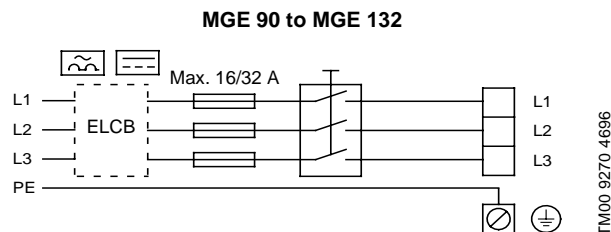

Actual mains connection is shown in figs. 6 and 7.

Fig. 6

MGE 90 and MGE 100

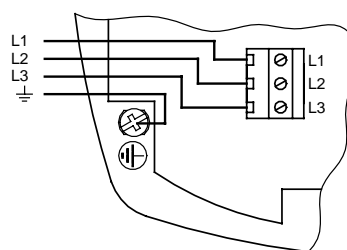
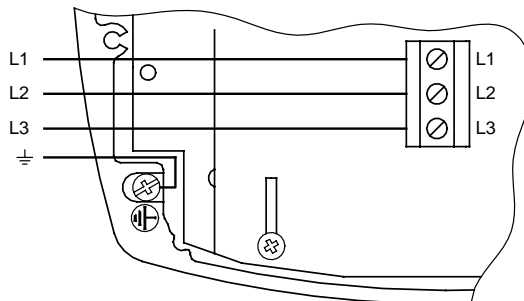

Fig. 7

MGE 112 and MGE 132



2.2.7 Start/stop of pump

The number of starts and stops via the mains voltage must not exceed 4 times per hour.

When the pump is switched on via the mains, it will start after approx. 5 seconds.

If a higher number of starts and stops is desired, the input for external start/stop must be used when starting/stopping the pump. When the pump is started/stopped via an external on/off switch, it will start immediately.

2.3 Other connections – single-phase pumps

Note: For single-phase TPED pumps, see section 2.4 *Other connections – single-phase TPED pumps*.

The connection terminals of external potential-free contacts for start/stop and digital function, external setpoint signal, sensor signal, GENIbus and relay signal are shown in fig. 8.

Note: If no external on/off switch is connected, short-circuit terminals 2 and 3 using a short wire.

Note: As a precaution, the wires to be connected to the following connection groups must be separated from each other by reinforced insulation in their entire lengths:

1. **Inputs** (external start/stop, digital function, setpoint and sensor signals, terminals 1-9, and bus connection, B, Y, A).

All inputs (group 1) are internally separated from the mains-conducting parts by reinforced insulation and galvanically separated from other circuits.

All control terminals are supplied by protective extra-low voltage (PELV), thus ensuring protection against electric shock.

2. **Output** (relay signal, terminals NC, C, NO).

The output (group 2) is galvanically separated from other circuits. Therefore, the supply voltage or protective extra-low voltage can be connected to the output as desired.

3. **Supply voltage** (terminals N, PE, L).

A galvanically safe separation must fulfil the requirements for reinforced insulation including creepage distances and clearances specified in EN 50 178.

Fig. 8

MGE 71 and MGE 80

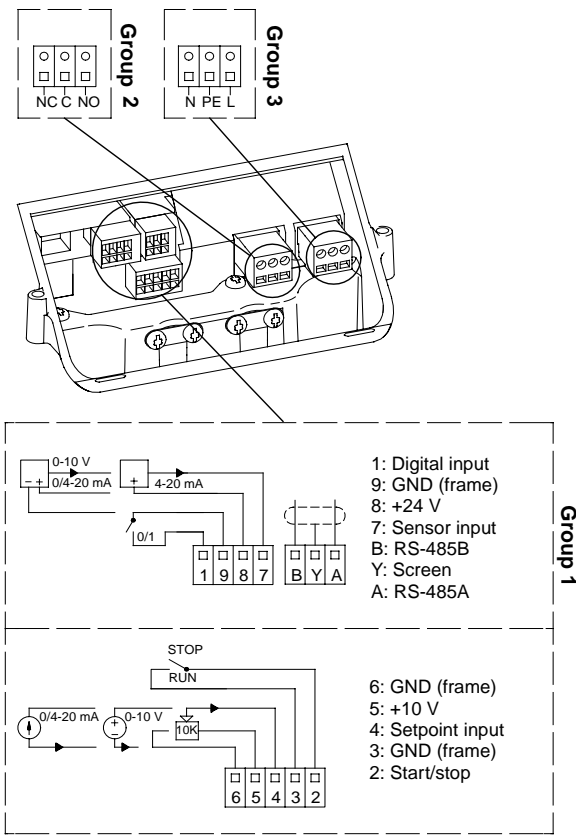

2.4 Other connections – single-phase TPED pumps

The connection terminals of external potential-free contacts for start/stop and digital function, external setpoint signal, sensor signal, GENIbus, relay signal and communication cable are shown in fig. 9.

Note: If no external on/off switch is connected, short-circuit terminals 2 and 3 using a short wire.

Note: As a precaution, the wires to be connected to the following connection groups must be separated from each other by reinforced insulation in their entire lengths:

1. **Inputs** (external start/stop, digital function, setpoint and sensor signals, terminals 1-9, and bus connection, B, Y, A).

All inputs (group 1) are internally separated from the mains-conducting parts by reinforced insulation and galvanically separated from other circuits.

All control terminals are supplied by protective extra-low voltage (PELV), thus ensuring protection against electric shock.

2. **Output** (relay signal, terminals NC, C, NO).

The output (group 2) is galvanically separated from other circuits. Therefore, the supply voltage or protective extra-low voltage can be connected to the output as desired.

3. **Supply voltage** (terminals N, PE, L).

4. **Communication cable** (8-pin male socket).

The communication cable is connected to the socket in group 4. The cable ensures communication between the two pumps, whether one or two pressure sensors are connected, see section 2.6 *Signal cables*.

The selector switch in group 4 enables changeover between the operating modes “alternating operation” and “standby operation”. See description in section 3.2.1 *Additional operating modes – single-phase TPED pumps*.

A galvanically safe separation must fulfil the requirements for reinforced insulation including creepage distances and clearances specified in EN 50 178.

Fig. 9

MGE 71 and MGE 80

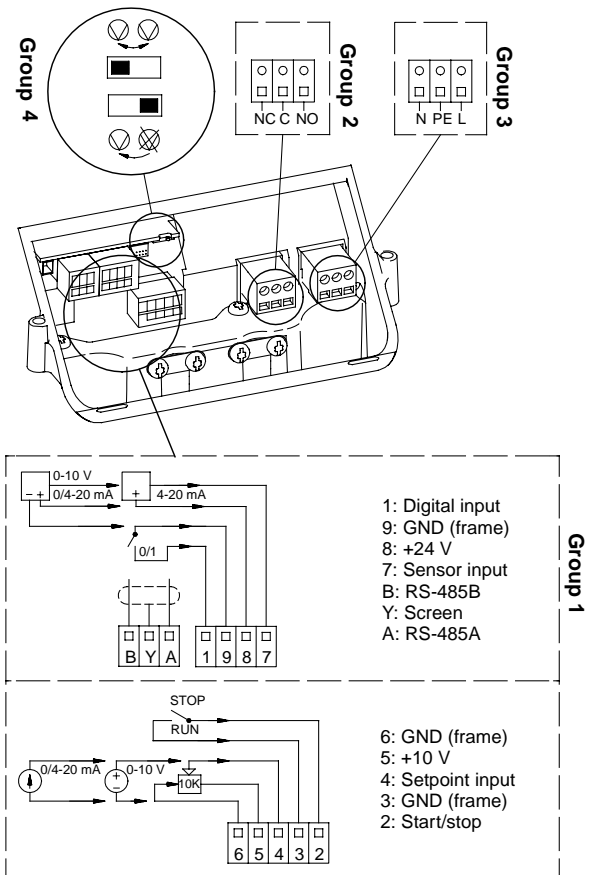

2.5 Other connections – three-phase pumps

The connection terminals of external potential-free contacts for start/stop and digital function, external setpoint signal, sensor signal, GENIbus and relay signal are shown in figs. 10 and 11.

Note: If no external on/off switch is connected, short-circuit terminals 2 and 3 using a short wire.

Note: As a precaution, the wires to be connected to the following connection groups must be separated from each other by reinforced insulation in their entire lengths:

1. **Inputs** (external start/stop, digital function, setpoint and sensor signals, terminals 1-8, and bus connection, A, Y, B).

All inputs (group 1) are internally separated from the mains-conducting parts by reinforced insulation and galvanically separated from other circuits.

All control terminals are supplied by protective extra-low voltage (PELV), thus ensuring protection against electric shock.

2. **Output** (relay signal, terminals NC, NO, C).

The output (group 2) is galvanically separated from other circuits. Therefore, the supply voltage or protective extra-low voltage can be connected to the output as desired.

3. **Supply voltage** (terminals L1, L2, L3).

A galvanically safe separation must fulfil the requirements for reinforced insulation including creepage distances and clearances specified in EN 50 178.

Fig. 10

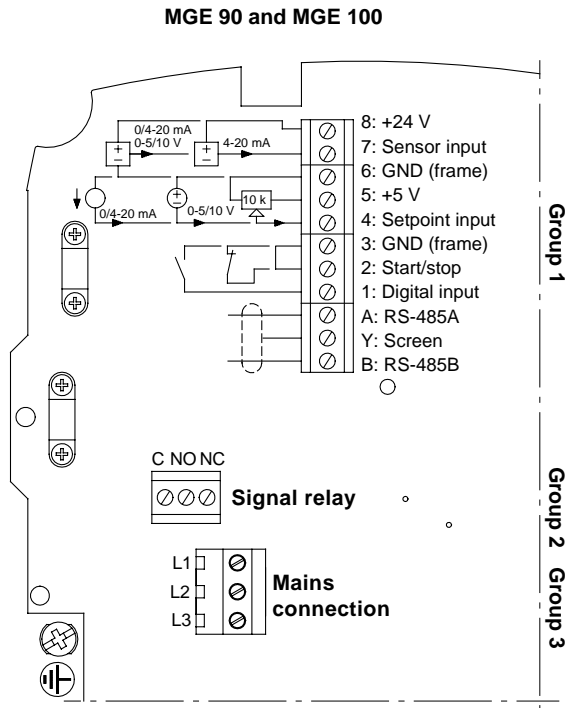

TM000 6788 0101

Fig. 11

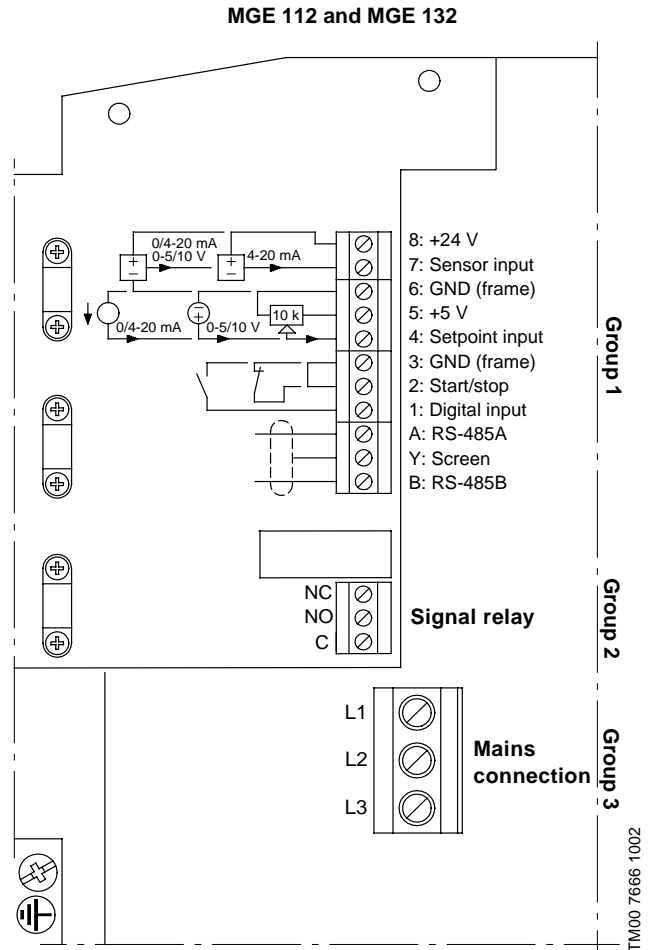

TM000 7666 1002

2.6 Signal cables

- Use screened cables having a cross-sectional area of min. 0.5 mm² and max. 1.5 mm² for external on/off switch, digital input, setpoint and sensor signals.
- The screens of the cables must be connected to frame at both ends with good frame connection. They must be as close as possible to the terminals, fig. 12.

Fig. 12

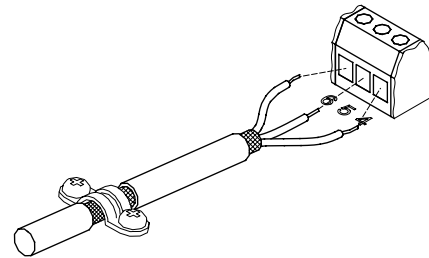

TM000 7667 1696

- Screws for frame connections must always be tightened whether a cable is fitted or not.
- The wires in the pump terminal box must be as short as possible.

For the bus connection a screened 2-core cable must be used. Connect the screen to terminal Y at both ends, fig. 13.

Fig. 13

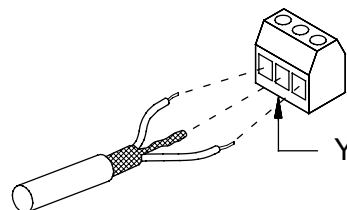

TM000 7601 0101

Communication cable for single-phase TPED pumps only:

Connect the communication cable between the two pump heads. A good frame connection near the cable clamp must be made.

See also the above description.

Fig. 14

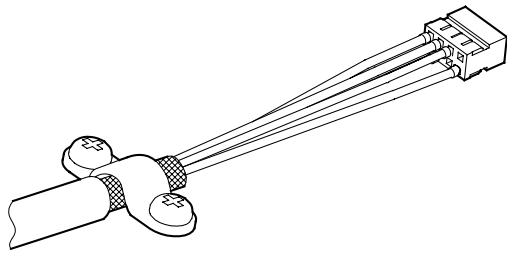

TM02 5991 4702

When connecting the communication cable, the following must be observed:

If **one sensor** is connected, insert the communication cable plugs into the sockets in the terminal boxes as shown in fig. 15.

Fig. 15

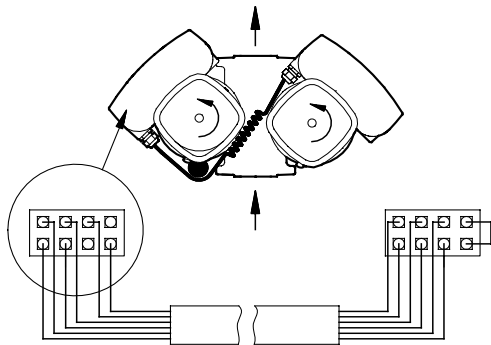

TM02 6012 4702

If **two sensors** are connected, cut the red wire, see fig. 16.

Fig. 16

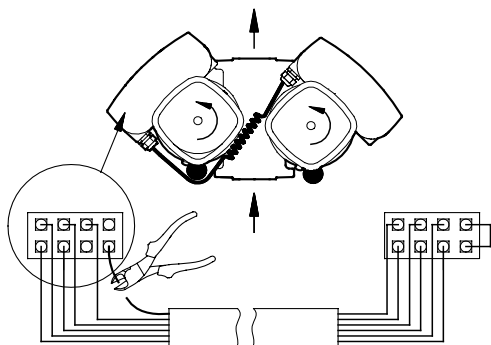

TM02 6013 4702

If **one sensor** is connected, it is connected to the master pump to the left of the flow direction.

If **two sensors** are connected, one sensor is connected to the master pump (to the left of the flow direction) and the other to the slave pump, see fig. 17.

Fig. 17

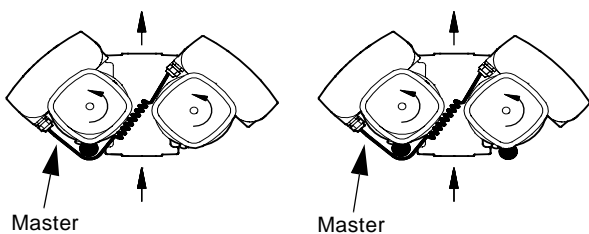

TM02 6014 4702

3. Setting the pump

3.1 Control modes

E-pumps can be set to two control modes, i.e:

- **controlled**-operation or
- **uncontrolled**-operation.

In **controlled**-operation mode, the pump will adjust its performance to the desired setpoint for the control parameter (pressure, differential pressure, temperature, differential temperature or flow). Figure 18 shows a differential-pressure controlled pump as an example of controlled operation.

In **uncontrolled**-operation mode, the pump will operate according to the constant curve set.

Fig. 18

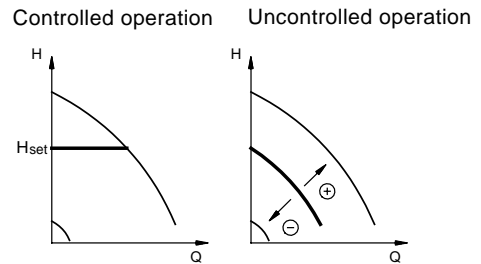

TM00 7668 1696

The pumps have been factory-set to uncontrolled operation, see section 3.3 *Factory setting*.

3.2 Operating modes

The following operating modes can be selected:

- Stop,
- Min.,
- Normal (controlled or uncontrolled operation),
- Max.

The operating modes can all be set on the pump control panel.

Fig. 19

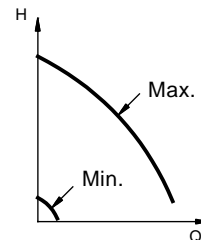

TM00 5547 0995

The min. curve can be used in periods in which a minimum flow is required.

The max. curve can for instance be used in connection with the venting procedure during installation.

If the electricity supply to the pump is disconnected, the pump setting will be stored.

The remote control R100 offers additional possibilities of setting and status displays, see section 5. *Setting by means of R100*.

3.2.1 Additional operating modes – single-phase TPED pumps

The single-phase TPED pumps offer the following additional operating modes:

- **Alternating operation.** Pump operation alternates every 24 hours. If the duty pump stops due to a fault, the other pump will start.
- **Standby operation.** One pump is operating continuously. In order to prevent seizing-up, the other pump is started 10 sec. every 24 hours. If the duty pump stops due to a fault, the other pump will start.

The operating mode is selected by means of a selector switch in each terminal box, see fig. 9.

The selector switches enable changeover between the operating modes “**alternating operation**” (left position) and “**standby operation**” (right position).

The switches in the two terminal boxes must be set to the same position. If the switches are positioned differently, “standby operation” is selected.

Twin-head pumps can be set and operated in the same way as single-head pumps. The duty pump uses its setpoint setting, whether it is made by means of the control panel, via the R100 or via bus.

Note: Both pumps should be set to the same setpoint and control mode. Different settings will result in different operation when changing between the two pumps.

If the electricity supply to the pump is disconnected, the pump setting will be stored.

The remote control R100 offers additional possibilities of setting and status displays, see section 5. *Setting by means of R100.*

3.3 Factory setting

Note: For single-phase TPED pumps, see section 3.4 *Factory setting – single-phase TPED pumps.*

The pumps have been factory-set to uncontrolled operation. The setpoint value corresponds to 100% of the maximum pump performance (see data sheet for the pump).

Other pump settings are marked with **bold**-faced type under each individual display in sections 5.1 *Menu OPERATION* and 5.3 *Menu INSTALLATION.*

3.4 Factory setting – single-phase TPED pumps

The pumps have been factory-set to uncontrolled operation and the additional operating mode “alternating operation”.

The setpoint value corresponds to 100% of the maximum pump performance (see data sheet for the pump).

Other pump settings are marked with **bold**-faced type under each individual display in sections 5.1 *Menu OPERATION* and 5.3 *Menu INSTALLATION.*

4. Setting by means of control panel



At high system temperatures, the pump may be so hot that only the buttons should be touched to avoid burns.

The pump control panel, fig. 20, incorporates the following:

- Buttons, “+” and “-”, for setpoint setting.
- Light fields, yellow, for indication of setpoint.
- Indicator lights, green (operation) and red (fault).

Fig. 20

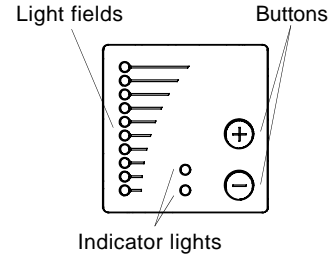

TM00 7600 1196

4.1 Setpoint setting

The desired setpoint is set by pressing the button “+” or “-”.

The light fields on the control panel will indicate the setpoint set. See the following examples, figs. 21 and 22.

Example: Pump in controlled-operation mode (differential pressure control):

Figure 21 shows that the light fields 5 and 6 are activated, indicating a desired setpoint of 4 m with a sensor measuring range from 0 to 8 m. The setting range is equal to the sensor measuring range (see sensor nameplate).

Fig. 21

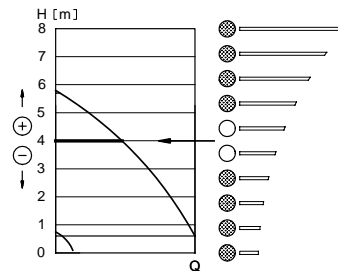

TM00 7749 1896

Example: Pump in uncontrolled-operation mode:

In uncontrolled-operation mode, the pump performance is set within the range from min. to max. curve, fig. 22.

Fig. 22

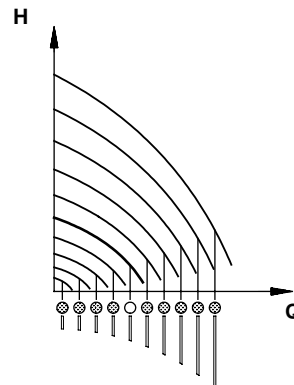

TM00 7746 1896

4.2 Setting to max. curve duty

Press “+” continuously to change over to the max. curve of the pump (top light field flashes). When the top light field is on, “+” must be pressed for 3 seconds before the light field starts flashing.

To change back, press “-” continuously until the desired setpoint is indicated.

Fig. 23

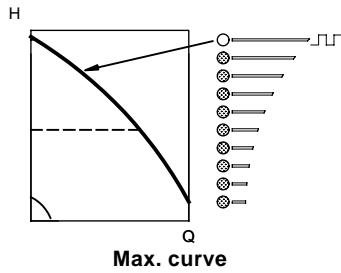

TM00 7345 1196

4.3 Setting to min. curve duty

Press “-” continuously to change over to the min. curve of the pump (bottom light field flashes). When the bottom light field is on, “-” must be pressed for 3 seconds before the light field starts flashing.

To change back, press “+” continuously until the desired setpoint is indicated.

Fig. 24

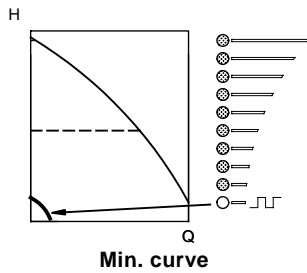

TM00 7346 1196

4.4 Start/stop of pump

Stop the pump by continuously pressing “-” until none of the light fields are activated and the green indicator light flashes.

Start the pump by continuously pressing “+” until the desired setpoint is indicated.

5. Setting by means of R100

The pump is designed for wireless communication with the GRUNDFOS remote control R100.

Fig. 25

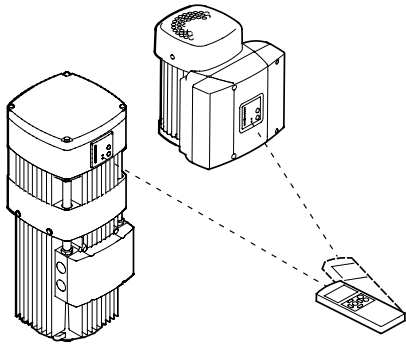
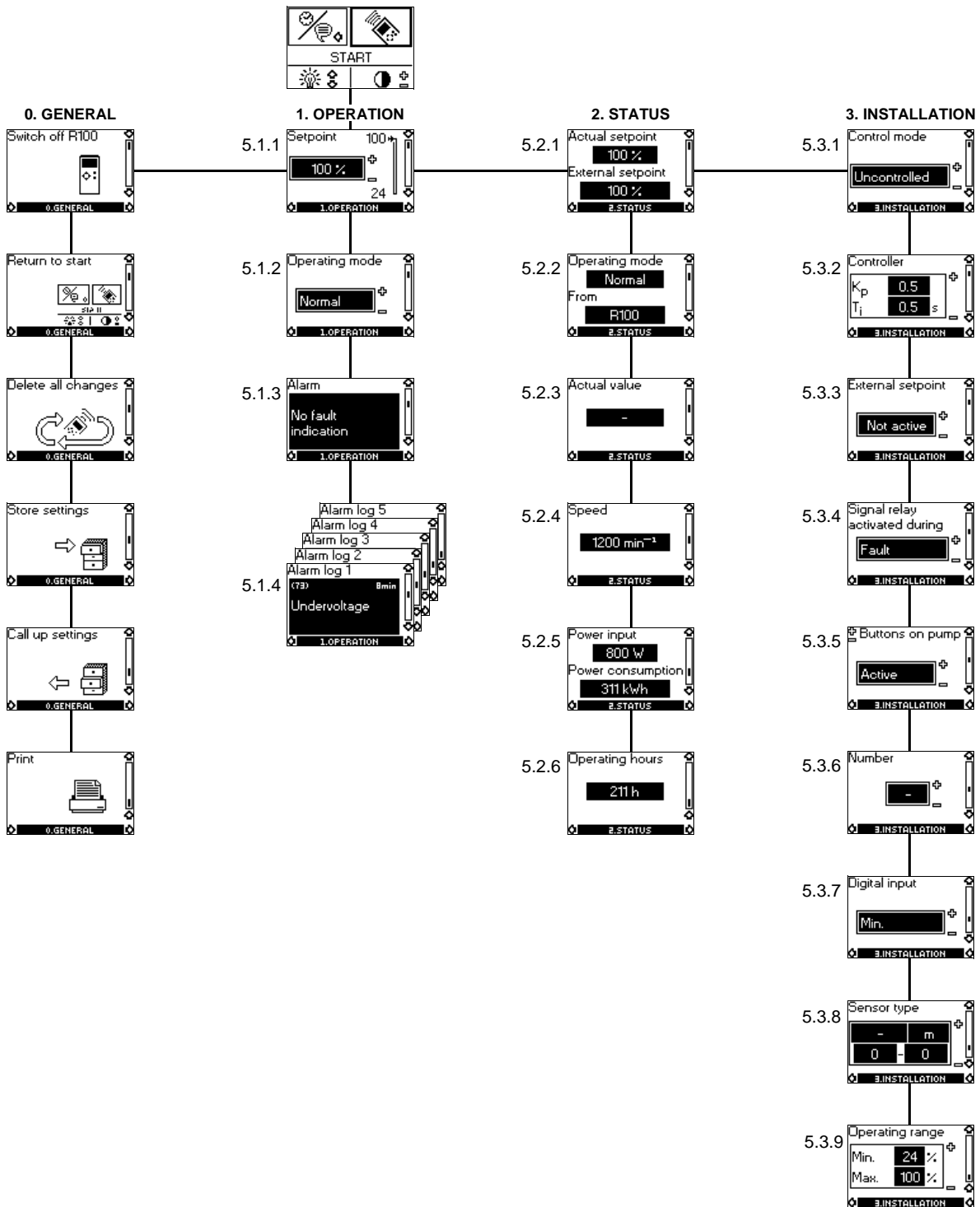

Fig. 26



TM02 0791 0101

The R100 communicates with the pump via infra-red light. The transmitter and the receiver are incorporated in the pump control panel, fig. 25.

During communication, the R100 must be pointed at the control panel.

When the R100 communicates with the pump, the red indicator light will flash rapidly.

The R100 offers additional possibilities of setting and status displays for the pump.

The displays are divided into four parallel menus, fig. 26:

0. GENERAL (see operating instructions for the R100)

1. OPERATION

2. STATUS

3. INSTALLATION

The number stated at each individual display in fig. 26 refers to the section in which the display is described.

5.1 Menu OPERATION

When communication between the R100 and the pump has been established, the first display in this menu will appear.

5.1.1 Setpoint setting

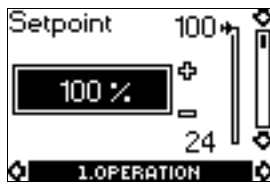

- ▶ Setpoint set
- Actual setpoint
- Actual value

In this display, the setpoint is set.

In **controlled**-operation mode, the setting range is equal to the sensor measuring range, e.g. 0 to 25 m.

In **uncontrolled**-operation mode, the setpoint is set in % of the maximum performance. The setting range will lie between the min. and max. curves.

Select one of the following operating modes:

- *Stop*,
- *Min.* (min. curve),
- *Max.* (max. curve).

If the pump is connected to an external setpoint signal, the setpoint in this display will be the maximum value of the external setpoint signal, see section 7. *External setpoint signal*.

If the pump is controlled via external signals (*Stop*, *Min.* curve or *Max.* curve) or a bus, this will be indicated in the display if setpoint setting is attempted.

In this case, the number of possible settings will be reduced, see section 9. *Priority of settings*.

5.1.2 Setting of operating mode

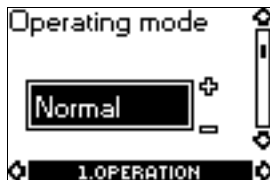

Select one of the following operating modes:

- *Stop*,
- *Min.*,
- **Normal** (duty),
- *Max.*

The operating modes can be selected without changing the setpoint setting.

5.1.3 Fault indications

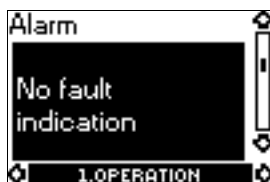

If the pump is faulty, the cause will appear in this display.

Possible causes:

- *Too high motor temperature*
- *Undervoltage*
- *Overvoltage*
- *Phase failure* (three-phase pumps only)
- *Mains supply failure* (three-phase pumps only)
- *Too many restarts* (after faults)
- *Overload*
- *Sensor signal outside signal range* (only 4-20 mA)

- *Setpoint signal outside signal range* (only 4-20 mA)
- *Dry running*
- *Other fault*

A fault indication can be reset in this display if the cause of the fault has disappeared.

5.1.4 Alarm log

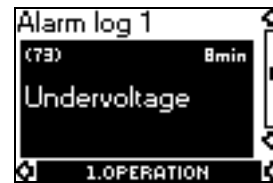

If faults have been indicated, the last five fault indications will appear in the alarm log. "Alarm log 1" shows the newest/latest fault.

The example shows the fault indication "Undervoltage", the fault code and the number of minutes the pump has been connected to the electricity supply after the fault occurred.

The time cannot be displayed for three-phase pumps as the software does not support this function.

5.2 Menu STATUS

The displays appearing in this menu are status displays only. It is not possible to change or set values.

The displayed values are the values that applied when the last communication between the pump and the R100 took place. If a status value is to be updated, point the R100 at the control panel and press "OK".

If a parameter, e.g. speed, should be called up continuously, press "OK" constantly during the period in which the parameter in question should be monitored.

The tolerance of the displayed value is stated under each display. The tolerances are stated as a guide in % of the maximum values of the parameters.

5.2.1 Display of actual setpoint

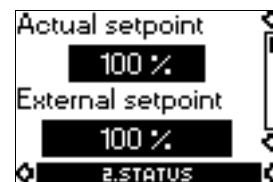

Tolerance: $\pm 2\%$

This display shows the actual setpoint and the external setpoint in % of the range from minimum value to the setpoint set, see section 7. *External setpoint signal*.

5.2.2 Display of operating mode



This display shows the actual operating mode (*Stop*, *Min.*, *Normal* (duty) or *Max.*). Furthermore, it shows where this operating mode was selected (*R100*, *Pump*, *BUS* or *External*).

5.2.3 Display of actual value



The actually measured value of a connected sensor will appear in this display, e.g. 12 metres.

If no sensor is connected to the pump, "-" will appear in the display.

5.2.4 Display of actual speed



Tolerance: $\pm 5\%$

The actual pump speed will appear in this display.

5.2.5 Display of input power and power consumption

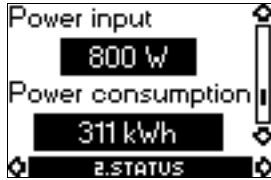

Tolerance: $\pm 10\%$

This display shows the actual pump input power from the mains supply. The power is displayed in W or kW.

The pump power consumption can also be read from this display. The value of power consumption is an accumulated value calculated from the pump's birth and it cannot be reset.

5.2.6 Display of operating hours



Tolerance: $\pm 2\%$

The value of operating hours is an accumulated value and cannot be reset.

5.3 Menu INSTALLATION

5.3.1 Selection of control mode



Select one of the following control modes (see fig. 18):

- *Controlled*,
- **Uncontrolled.**

The desired performance is set in section 5.1.1 *Setpoint setting*.

Note: If the pump is connected to a bus (see section 8. *Bus signal*), it is not possible to select the control mode via the R100.

5.3.2 Setting of controller

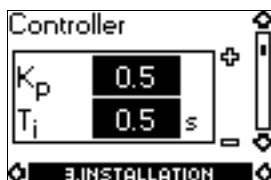

In this display, the gain (K_p) and the integral-action time (T_i) of the built-in PI controller can be set if the factory setting is not the optimum setting:

- The gain (K_p) is set within the range from 0.1 to 20.
- The integral-action time (T_i) is set within the range from 0.1 to 3600 s. If 3600 s is selected, the controller will function as a P controller.

Furthermore, it is possible to set the controller to inverse control (if the setpoint is increased, the speed will be reduced). In the case of inverse control, the gain (K_p) must be set within the range from -0.1 to -20 .

Setting the PI controller:

For most applications, the factory setting of the controller constants K_p and T_i will ensure optimum pump operation. In the following cases, a change of the setting can be useful or necessary.

A change of the T_i setting can be useful:

- in a differential-pressure control system if the sensor is placed far away from the pump.

A change of the T_i setting, and in some cases the K_p setting, may be necessary:

- if the pump is controlled on the basis of temperature or differential temperature.

The table below shows the recommended controller settings:

System/ application	K_p		T_i
	Heating system ¹⁾	Cooling system ²⁾	
	0.5		0.5
	0.5		L < 5 m: 0.5 L > 5 m: 3 L > 10 m: 5
	0.5		0.5
	0.5		0.5
	0.5	-0.5	10 + 5L
	0.5		10 + 5L
	0.5	-0.5	30 + 5L

- 1) Heating systems are systems in which an increase in pump performance will result in a **rise** in temperature at the sensor.
- 2) Cooling systems are systems in which an increase in pump performance will result in a **drop** in temperature at the sensor.

5.3.3 Selection of external setpoint signal



The input for external setpoint signal can be set to different signal types.

Select one of the following types:

- 0-5 V (three-phase pumps only),
- 0-10 V,
- 0-20 mA,
- 4-20 mA,
- **Not active.**

If *Not active* is selected, the setpoint set by means of the R100 or on the control panel will apply.

The setpoint set is the maximum value of the external setpoint signal, section 7. *External setpoint signal*. The actual value of the external setpoint can be read from section 5.2.1 *Display of actual setpoint*.

5.3.4 Selection of fault, operating or ready signal relay



It can be selected in which situation the relay should be activated:

- **Fault** (fault indication),
- *Operation* (operating indication),
- *Ready* (ready indication).

See section 10. *Indicator lights and signal relay*.

5.3.5 Blocking of the buttons on the pump



The buttons "+" and "-" on the pump can be set to:

- **Active,**
- *Not active.*

5.3.6 Allocation of pump number



A number between 1 and 64 can be allocated to the pump. In the case of bus communication, a number must be allocated to each pump.

5.3.7 Selection of function for digital input



The digital input of the pump (terminal 1, fig. 8, 9,10 or 11) can be set to different functions.

Select one of the following functions:

- **Min.** (min. curve),
- **Max.** (max. curve).

The selected function is activated by closing the contact between the following terminals:

- 1 and 9 of single-phase pumps (fig. 8 or 9) and
- 1 and 3 of three-phase pumps (fig. 10 or 11).

See also section 6.2 *Digital input*.

Min.:

When the input is activated, the pump is operating according to the min. curve.

Max.:

When the input is activated, the pump is operating according to the max. curve.

5.3.8 Setting of sensor

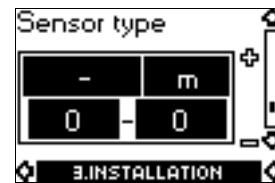

The setting of the sensor is only carried out in the case of controlled operation.

Select the following:

- Sensor output signal (0-5 V (three-phase pumps only), 0-10 V, 0-20 mA or 4-20 mA),
- sensor measuring unit (*bar, mbar, m, kPa, psi, ft, m³/h, m³/s, l/s, gpm, °C, °F or %*) and
- sensor measuring range.

5.3.9 Setting of min. and max. curves

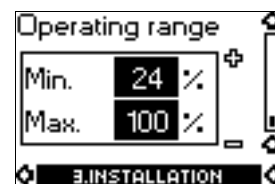

Set the min. and max. curves in % of maximum performance if the operating range must be reduced, fig. 27.

Fig. 27

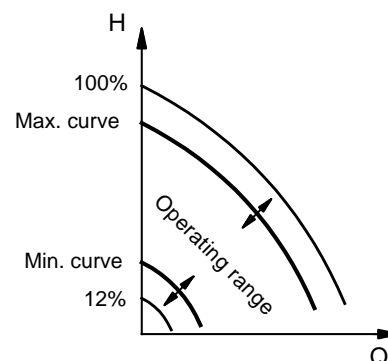

- The max. curve can be adjusted within the range from maximum performance (100%) to min. curve.
- The min. curve can be adjusted within the range from max. curve to 12% of maximum performance. The pump has been factory-set to 24% of maximum performance.
- The operating range lies between the min. and max. curves.

6. External forced-control signals

The pump has inputs for external signals for the forced-control functions:

- Start/stop of pump.
- Digital function.

6.1 Start/stop input

Functional diagram: Start/stop input:

Start/stop (terminals 2 and 3)		
		Normal duty
		Stop

6.2 Digital input

By means of the R100, one of the following functions can be selected for the digital input:

- Min. curve.
- Max. curve.

Functional diagram: Input for digital function:

Digital function (terminals 1 and 9 – single-phase pumps) (terminals 1 and 3 – three-phase pumps)		
		Normal duty
		Min. curve
		Max. curve

7. External setpoint signal

By connecting an analog signal transmitter to the input for the setpoint signal (terminal 4), it is possible to remote-set the setpoint.

The actual external signal (0-5 V (three-phase pumps only), 0-10 V, 0-20 mA, 4-20 mA) must be selected via the R100, see section 5.3.3 *Selection of external setpoint signal*.

If uncontrolled operation is selected by means of the R100, the pump can be controlled by any controller.

In **controlled**-operation mode, the setpoint can be set externally within the range from the lower value of the sensor measuring range to the setpoint set on the pump or by means of the R100, fig. 28.

Fig. 28

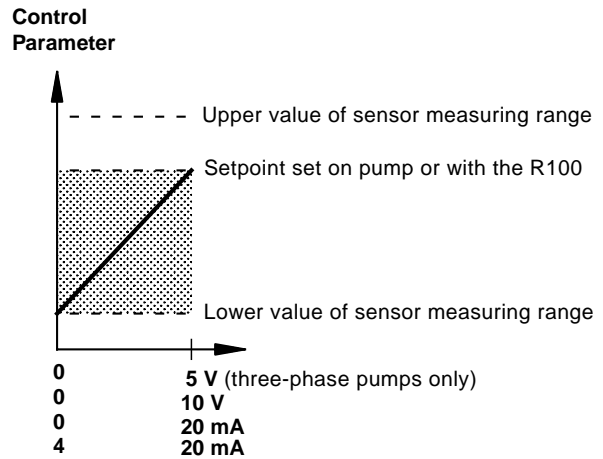

Example: At a lower differential-pressure sensor value of 0 m, a setpoint set of 20 m and an external setpoint of 80%, the actual setpoint will be as follows:

$$\begin{aligned}
 H_{\text{actual}} &= (H_{\text{set}} - H_{\text{lower}}) \times \%_{\text{external setpoint}} + H_{\text{lower}} \\
 &= (20 - 0) \times 80\% + 0 \\
 &= 16 \text{ m}
 \end{aligned}$$

In **uncontrolled**-operation mode, the setpoint can be set externally within the range from the min. curve to the setpoint set on the pump or by means of the R100, fig. 29.

Fig. 29

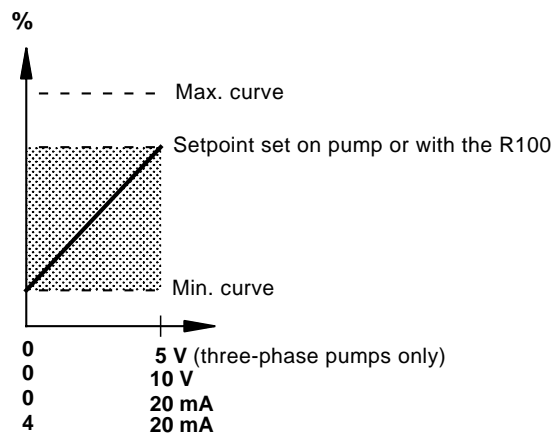

8. Bus signal

The pump enables serial communication via an RS-485 input. The communication is carried out according to the GRUNDFOS bus protocol, GENIbus protocol, and enables connection to a building management system or another external control system.

Via the bus signal, it is possible to remote-set pump operating parameters, like setpoint, operating mode, etc. At the same time, the pump can provide status information about important parameters, like actual value of control parameter, input power, fault indications, etc.

Contact GRUNDFOS for further details.

Note: If a bus signal is used, the number of settings available via the R100 will be reduced.

9. Priority of settings

The start/stop and digital inputs will influence the number of possible settings.

By means of the R100, the pump can always be set to max. curve duty or to stop.

If two or more functions are activated at the same time, the pump will operate according to the function with the highest priority.

The priority of the settings is as shown in the following tables:

Without bus signal		
Priority	Possible settings	
	Control panel on pump or R100	External signals
1	Stop	
2	Max. curve	
3		Stop
4		Max. curve
5	Min. curve	Min. curve
6	Setpoint setting	Setpoint setting

Example: If, via the digital input, the pump has been forced to operate according to the max. curve, the pump control panel and the R100 can only set the pump to stop.

With bus signal			
Priority	Possible settings		
	Control panel on pump or R100	External signals	Bus signal
1	Stop		
2	Max. curve		
3		Stop	Stop
4			Max. curve
5			Min. curve
6			Setpoint setting

Example: If, via the digital input, the pump has been forced to operate according to the max. curve, the pump control panel, the R100 and the bus signal can only set the pump to stop.

10. Indicator lights and signal relay

The operating condition of the pump is indicated by the green and red indicator lights on the pump control panel, fig. 30.

Fig. 30

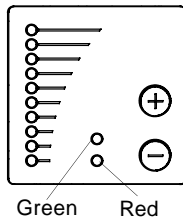

TMM00 7600 1196

The pump incorporates an output for a potential-free signal via an internal relay.

The signal output can be set to fault, operating or ready indication by means of the R100, see section 5.3.4 *Selection of fault, operating or ready signal relay*.

The functions of the two indicator lights and the signal relay are as shown in the following table:

Indicator lights		Signal relay activated during:			Description
Fault (red)	Operation (green)	Fault	Operation	Ready	
Off	Off				The electricity supply has been switched off.
Off	Permanently on				The pump is operating.
Off	Flashing				The pump has been set to stop.
Permanently on	Off				The pump has stopped because of a fault. Restarting will be attempted (it may be necessary to restart the pump by resetting the fault indication).
Permanently on	Permanently on				The pump is operating, but it has been stopped because of a fault. If the cause is "sensor signal outside signal range", the pump will continue operating according to the max. curve and the fault indication cannot be reset until the signal is inside the signal range. If the cause is "setpoint signal outside signal range", the pump will continue operating according to the min. curve and the fault indication cannot be reset until the signal is inside the signal range.
Permanently on	Flashing				The pump has been set to stop, but it has been stopped because of a fault.

A fault indication can be reset in one of the following ways:

- By briefly pressing the button "+" or "-" on the pump. This will not change the setting of the pump.
A fault indication cannot be reset by means of "+" or "-" if the buttons have been locked.
- By switching off the electricity supply until the indicator lights are off.
- By means of the R100, see section 5.1.3 *Fault indications*.

When the R100 communicates with the pump, the red indicator light will flash rapidly.

11. Megging

Note: Megging of an installation incorporating E-pumps is not allowed, as the built-in electronics may be damaged.

12. Technical data – single-phase pumps

12.1 Supply voltage

1 x 200-240 V $\pm 10\%$, 50/60 Hz, PE.

See nameplate.

Back-up fuse

Motor sizes from 0.37 to 1.1 kW: Max. 10 A.

Standard as well as quick-blow or slow-blow fuses may be used.

12.2 Leakage current

Earth leakage current < 3.5 mA.

The leakage currents are measured in accordance with EN 60 355-1.

12.3 Inputs/output

Start/stop

External potential-free switch.

Voltage: 5 VDC.

Current: < 5 mA.

Screened cable.*

Digital

External potential-free switch.

Voltage: 5 VDC.

Current: < 5 mA.

Screened cable.*

Setpoint signals

- Potentiometer
0-10 VDC, 10 k Ω (via internal voltage supply).
Screened cable.*
Maximum cable length: 100 m.
- Voltage signal
0-10 VDC, $R_i > 50$ k Ω .
Tolerance: +0%/-3% at maximum voltage signal.
Screened cable.*
Maximum cable length: 500 m.
- Current signal
DC 0-20 mA/4-20 mA, $R_i = 175$ Ω .
Tolerance: +0%/-3% at maximum current signal.
Screened cable.*
Maximum cable length: 500 m.

Sensor signals

- Voltage signal
0-10 VDC, $R_i > 50$ k Ω (via internal voltage supply).
Tolerance: +0%/-3% at maximum voltage signal.
Screened cable.*
Maximum cable length: 500 m.
- Current signal
DC 0-20 mA/4-20 mA, $R_i = 175$ Ω .
Tolerance: +0%/-3% at maximum current signal.
Screened cable.*
Maximum cable length: 500 m.
- Electricity supply to sensor:
+24 VDC, max. 40 mA.

Signal output

Potential-free changeover contact.

Maximum contact load: 250 VAC, 2 A.

Minimum contact load: 5 VDC, 1 mA.

Screened cable: 0.5 - 2.5 mm².

Maximum cable length: 500 m.

Bus input

GRUNDFOS bus protocol, GENIbus protocol, RS-485.

0.5 - 1.5 mm² screened 2-core cable.

Maximum cable length: 500 m.

* Cross section min. 0.5 mm² and max. 1.5 mm².

13. Technical data – three-phase pumps

13.1 Supply voltage

3 x 380-415 V $\pm 10\%$, 50/60 Hz, PE.

See nameplate.

Back-up fuse

Motor sizes from 1.1 to 5.5 kW: Max. 16 A.

Motor size 7.5 kW: Max. 32 A.

Standard as well as quick-blow or slow-blow fuses may be used.

13.2 Leakage current

Motor size [kW]	Leakage current [mA]
1.1 to 3.0	< 3.5
4.0 to 5.5	< 5
5.5 kW, 1400-1800 min ⁻¹	< 10
7.5	< 10

The leakage currents are measured in accordance with EN 60 355-1.

13.3 Inputs/output

Start/stop

External potential-free switch.

Voltage: 5 VDC.

Current: < 5 mA.

Screened cable.*

Digital

External potential-free switch.

Voltage: 5 VDC.

Current: < 5 mA.

Screened cable.*

Setpoint signals

- Potentiometer
0-5 VDC, 10 k Ω (via internal voltage supply).
Screened cable.*
Maximum cable length: 100 m.
- Voltage signal
0-5 VDC/0-10 VDC, $R_i > 50$ k Ω .
Tolerance: +0%/-3% at maximum voltage signal.
Screened cable.*
Maximum cable length: 500 m.
- Current signal
DC 0-20 mA/4-20 mA, $R_i = 250$ Ω .
Tolerance: +0%/-3% at maximum current signal.
Screened cable.*
Maximum cable length: 500 m.

Sensor signals

- Voltage signal
0-5 VDC/0-10 VDC, $R_i > 50$ k Ω (via internal voltage supply).
Tolerance: +0%/-3% at maximum voltage signal.
Screened cable.*
Maximum cable length: 500 m.
- Current signal
DC 0-20 mA/4-20 mA, $R_i = 250$ Ω .
Tolerance: +0%/-3% at maximum current signal.
Screened cable.*
Maximum cable length: 500 m.
- Electricity supply to sensor:
+24 VDC, max. 40 mA.

Signal output

Potential-free changeover contact.

Maximum contact load: 250 VAC, 2 A.

Minimum contact load: 5 VDC, 1 mA.

Screened cable: 0.5 - 2.5 mm².

Maximum cable length: 500 m.

Bus input

GRUNDFOS bus protocol, GENIbus protocol, RS-485.

0.5 - 1.5 mm² screened 2-core cable.

Maximum cable length: 500 m.

* Cross section min. 0.5 mm² and max. 1.5 mm².

13.4 Other technical data

EMC (electromagnetic compatibility)

EN 61 800-3.

Motors of 0.37 to 5.5 kW, except for 5.5 kW, 1400-1800 min⁻¹:

Residential areas - unlimited distribution,
corresponding to CISPR 11, class B, group 1.

Motors of 7.5 kW and 5.5 kW, 1400-1800 min⁻¹:

Residential areas - limited distribution.

Industrial areas - unlimited distribution,
corresponding to CISPR 11, class A, group 1.

When pumps fitted with motors of 7.5 kW and 5.5 kW,
1400-1800 min⁻¹, are installed in residential areas, an additional
EMC filter is required to obtain class B, group 1 status.

The motor fulfils EN 50 178.

Contact GRUNDFOS for further information.

Enclosure class

Standard: IP 55 (IEC 34-5).

Insulation class

F (IEC 85).

Ambient temperature

During operation: -20°C to +40°C.

During storage/transport: -40°C to +60°C.

Relative air humidity

Maximum 95%.

Sound pressure level

Single-phase pumps:

<70 dB(A).

Three-phase pumps:

Motor [kW]	Speed stated on nameplate [min ⁻¹]	Sound pressure level [dB(A)]
1.1	1400-1500	52
	1700-1800	55
1.5	1400-1500	53
	1700-1800	56
	2800-3000	63
	3400-3600	68
2.2	1400-1500	52
	1700-1800	54
	2800-3000	64
3.0	1400-1500	57
	1700-1800	59
	2800-3000	64
	3400-3600	68
4.0	1400-1500	59
	2800-3000	68
	3400-3600	73
5.5	2800-3000	68
	3400-3600	73
7.5	2800-3000	74
	3400-3600	79

14. Disposal

Disposal of this product or parts of it must be carried out according to the following guidelines:

1. Use the local public or private waste collection service.
2. In case such waste collection service does not exist or cannot handle the materials used in the product, please deliver the product or any hazardous materials from it to your nearest GRUNDFOS company or service workshop.

Subject to alterations.

Denmark

GRUNDFOS DK A/S
Poul Due Jensens Vej 7A
DK-8850 Bjerringbro
Tlf.: +45-87 50 50 50
Telefax: +45-87 50 51 51
E-mail: info_GDK@grundfos.com
www.grundfos.com/DK

Argentina

Bombas GRUNDFOS de Argentina S.A.
Ruta Panamericana km. 37.500 Lote 34A
1619 - Garin
Pcia. de Buenos Aires
Phone: +54-3327 414 444
Telefax: +54-3327 411 111

Australia

GRUNDFOS Pumps Pty. Ltd.
P.O. Box 2040
Regency Park
South Australia 5942
Phone: +61-8-8461-4611
Telefax: +61-8-8340 0155

Austria

GRUNDFOS Pumpen Vertrieb Ges.m.b.H.
Grundfosstraße 2
A-5082 Grödig/Salzburg
Tel.: +43-6246-883-0
Telefax: +43-6246-883-30

Belgium

N.V. GRUNDFOS Bellux S.A.
Boomsesteenweg 81-83
B-2630 Aartselaar
Tél.: +32-3-870 7300
Télécopie: +32-3-870 7301

Brazil

GRUNDFOS do Brasil Ltda.
Rua Tomazina 106
CEP 83325 - 040
Pinhais - PR
Phone: +55-41 668 3555
Telefax: +55-41 668 3554

Canada

GRUNDFOS Canada Inc.
2941 Brighton Road
Oakville, Ontario
L6H 6C9
Phone: +1-905 829 9533
Telefax: +1-905 829 9512

China

GRUNDFOS Pumps (Shanghai) Co. Ltd.
22 Floor, Xin Hua Lian Building
755-775 Huai Hai Rd, (M)
Shanghai 200020
PRC
Phone: +86-512-67 61 11 80
Telefax: +86-512-67 61 81 67

Czech Republic

GRUNDFOS s.r.o.
Cajkovského 21
779 00 Olomouc
Phone: +420-585-716 111
Telefax: +420-585-438 906

Finland

OY GRUNDFOS Pumput AB
Mestarintie 11
Piispankylä
FIN-01730 Vantaa (Helsinki)
Phone: +358-9 878 9150
Telefax: +358-9 878 91550

France

Pompes GRUNDFOS Distribution S.A.
Parc d'Activités de Chesnes
57, rue de Malacombe
F-38290 St. Quentin Fallavier (Lyon)
Tél.: +33-4 74 82 15 15
Télécopie: +33-4 74 94 10 51

Germany

GRUNDFOS GMBH
Schlüterstr. 33
40699 Erkrath
Tel.: +49-(0) 211 929 69-0
Telefax: +49-(0) 211 929 69-3799
e-mail: infoservice@grundfos.de
Service in Deutschland:
e-mail: kundendienst@grundfos.de

Greece

GRUNDFOS Hellas A.E.B.E.
20th km. Athinon-Markopoulou Av.
P.O. Box 71
GR-19002 Peania
Phone: +0030-210-66 83 400
Telefax: +0030-210-66 46 273

Hong Kong

GRUNDFOS Pumps (Hong Kong) Ltd.
Unit 1, Ground floor
Siu Wai Industrial Centre
29-33 Wing Hong Street &
68 King Lam Street, Cheung Sha Wan
Kowloon
Phone: +852-27861706/27861741
Telefax: +852-27858664

Hungary

GRUNDFOS Hungária Kft.
Park u. 8
H-2045 Törökbalint,
Phone: +36-34 520 100
Telefax: +36-34 520 200

India

GRUNDFOS Pumps India Private Limited
Flat A, Ground Floor
61/62 Chamiers Aptmt
Chamiers Road
Chennai 600 028
Phone: +91-44 432 3487
Telefax: +91-44 432 3489

Indonesia

PT GRUNDFOS Pompa
Jl. Rawa Sumur III, Blok III / CC-1
Kawasan Industri, Pulogadung
Jakarta 13930
Phone: +62-21-460 6909
Telefax: +62-21-460 6910/460 6901

Ireland

GRUNDFOS (Ireland) Ltd.
Unit 34, Stillorgan Industrial Park
Blackrock
County Dublin
Phone: +353-1-2954926
Telefax: +353-1-2954739

Italy

GRUNDFOS Pompe Italia S.r.l.
Via Gran Sasso 4
I-20060 Truccazzano (Milano)
Tel.: +39-02-95838112
Telefax: +39-02-95309290/95838461

Japan

GRUNDFOS Pumps K.K.
1-2-3, Shin Miyakoda
Hamamatsu City
Shizuoka pref. 431-21
Phone: +81-53-428 4760
Telefax: +81-53-484 1014

Korea

GRUNDFOS Pumps Korea Ltd.
6th Floor, Aju Building 679-5
Yeoksam-dong, Kangnam-ku, 135-916
Seoul Korea
Phone: +82-2-5317 600
Telefax: +82-2-5633 725

Malaysia

GRUNDFOS Pumps Sdn. Bhd.
7 Jalan Peguam U1/25
Glenmarie Industrial Park
40150 Shah Alam
Selangor
Phone: +60-3-5569 2922
Telefax: +60-3-5569 2866

Mexico

Bombas GRUNDFOS de Mexico S.A. de C.V.
Boulevard TLC No. 15
Parque Industrial Stiva Aeropuerto
Apodaca, N.L. 66600
Mexico
Phone: +52-81-8144 4000
Telefax: +52-81-8144 4010

Netherlands

GRUNDFOS Nederland B.V.
Postbus 104
NL-1380 AC Weesp
Tel.: +31-294-492 211
Telefax: +31-294-492244/492299

New Zealand

GRUNDFOS Pumps NZ Ltd.
17 Beatrice Tinsley Crescent
North Harbour Industrial Estate
Albany, Auckland
Phone: +64-9-415 3240
Telefax: +64-9-415 3250

Norway

GRUNDFOS Pumper A/S
Strømsveien 344
Postboks 235, Leirdal
N-1011 Oslo
Tlf.: +47-22 90 47 00
Telefax: +47-22 32 21 50

Poland

GRUNDFOS Pompy Sp. z o.o.
ul. Klonowa 23
Baranowo k. Poznania
PL-62-081 Przemierowo
Phone: +48-61-650 13 00
Telefax: +48-61-650 13 50

Portugal

Bombas GRUNDFOS Portugal, S.A.
Rua Calvet de Magalhães, 241
Apartado 1079
P-2770-153 Paço de Arcos
Tel.: +351-21-440 76 00
Telefax: +351-21-440 76 90

Russia

OOO GRUNDFOS
Shkolnaya 39
RUS-109544 Moscow
Phone: +7-095 564 88 00, +7-095 737 30 00
Telefax: +7-095 564 88 11, +7-095 737 75 36
e-mail: grundfos.moscow@grundfos.com

Singapore

GRUNDFOS (Singapore) Pte. Ltd.
24 Tuas West Road
Jurong Town
Singapore 638381
Phone: +65-6865 1222
Telefax: +65-6861 8402

Spain

Bombas GRUNDFOS España S.A.
Camino de la Fuentequilla, s/n
E-28110 Algete (Madrid)
Tel.: +34-91-848 8800
Telefax: +34-91-628 0465

Sweden

GRUNDFOS AB
Box 63, Angeredsvinkeln 9
S-424 22 Angered
Tel.: +46-771-32 23 00
Telefax: +46-31 331 94 60

Switzerland

GRUNDFOS Pumpen AG
Bruggacherstrasse 10
CH-8117 Fällanden/ZH
Tel.: +41-1-806 8111
Telefax: +41-1-806 8115

Taiwan

GRUNDFOS Pumps (Taiwan) Ltd.
14, Min-Yu Road
Tunglo Industrial Park
Tunglo, Miao-Li County
Taiwan, R.O.C.
Phone: +886-37-98 05 57
Telefax: +886-37-98 05 70

Thailand

GRUNDFOS (Thailand) Ltd.
947/168 Moo 12, Bangna-Trad Rd., K.M. 3,
Bangna, Phrakonong
Bangkok 10260
Phone: +66-2-744 1785 ... 91
Telefax: +66-2-744 1775 ... 6

Turkey

GRUNDFOS POMPA SAN. ve TIC. LTD. STI
Bulgurlu Caddesi no. 32
TR-81190 Üsküdar Istanbul
Phone: +90 - 216-4280 306
Telefax: +90 - 216-3279 988

United Arab Emirates

GRUNDFOS Gulf Distribution
P.O. Box 16768
Jebel Ali Free Zone
Dubai
Phone: +971-4- 8815 166
Telefax: +971-4-8815 136

United Kingdom

GRUNDFOS Pumps Ltd.
Grovebury Road
Leighton Buzzard/Beds. LU7 8TL
Phone: +44-1525-850000
Telefax: +44-1525-850011

U.S.A.

GRUNDFOS Pumps Corporation
17100 West 118th Terrace
Olathe, Kansas 66061
Phone: +1-913-227-3400
Telefax: +1-913-227-3500

96 40 57 42 0203	134
Repl. 96 40 57 42 1002	