

WIRING INSTRUCTIONS

TITLE

LARGE DRILL POWER UNIT

BULLETIN

58-01-0371

MILWAUKEE ELECTRIC TOOL CORP.

13135 WEST LISBON RD. BROOKFIELD, WIS

DATE
Mar. '75

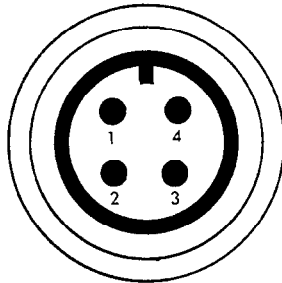

120V
CORD PLUG FACE

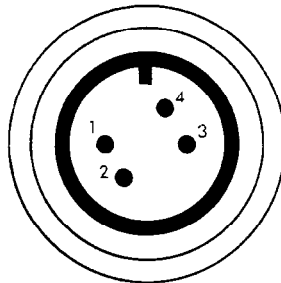

240V
CORD PLUG FACE

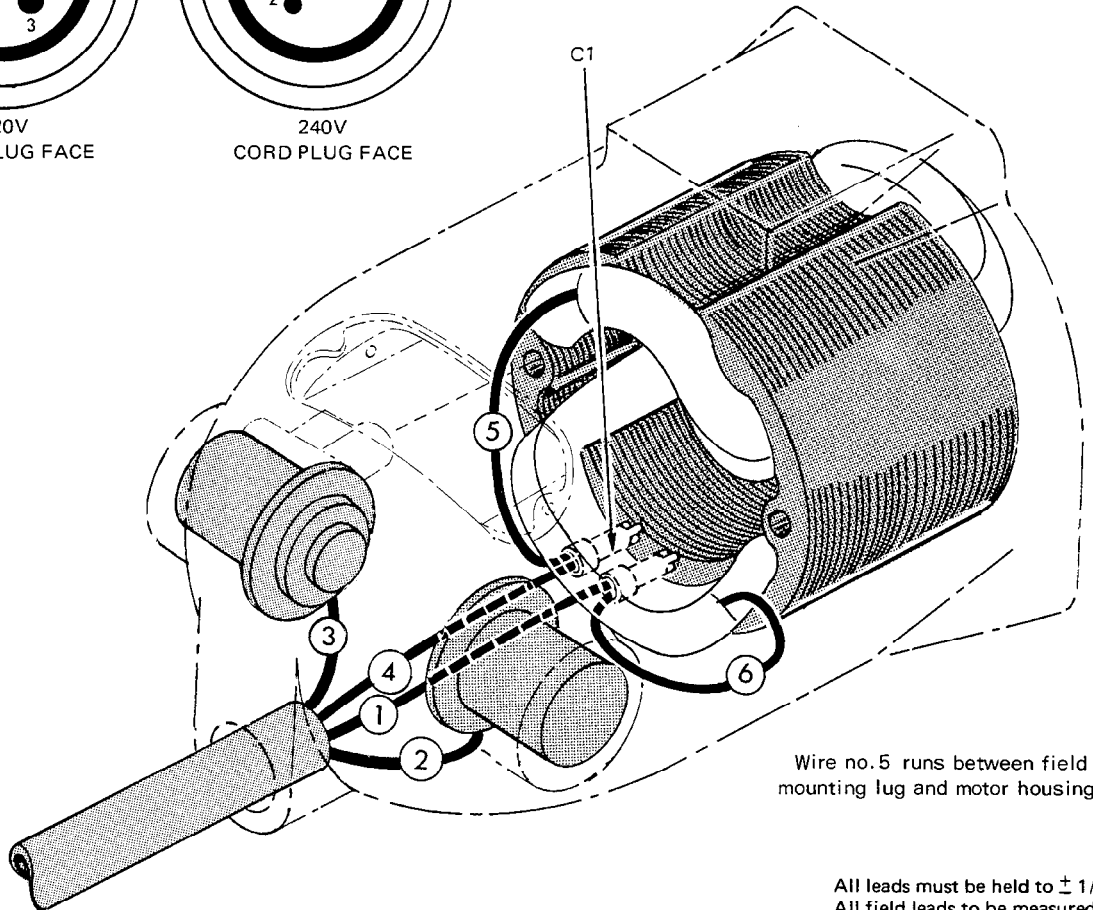

Wire no. 5 runs between field mounting lug and motor housing

Refer to electrical parts chart for terminal and connector part nos.
and quantity required — see drawing for actual hook-up.

All leads must be held to $\pm 1/8''$.
All field leads to be measured from
and perpendicular to laminations.
All lead lengths are before stripping.

WIRING SPECIFICATIONS

Wire No.	Wire Color	Origin or Gauge	Length	Terminal				Connector				
				T1	T2	T3	T4	C1	C2	C3	C4	
1	WHITE	CORD	2"									
2	RED	CORD	3-3/4"									
3	BLUE	CORD	3-3/4"									
4	BLACK	CORD	2"									
5	BLACK	FIELD	6-1/2"					X				
6	YELLOW	FIELD	3-3/4"					X				

ELECTRICAL PARTS

TERMINAL DESCRIPTION

Code	Part No.	Qty.

CONNECTOR DESCRIPTION

Code	Part No.	Qty.
C1	22-56-0160	2

SWITCH DESCRIPTION

Code	Part No.	Qty.