

## SELECTRONIC® HARD-WIRED AC POWERED PROXIMITY TOILET FLUSH VALVE 1.1, 1.28, 1.6, 1.6/1.1 & 1.28/1.1

### MODEL NUMBERS

6067.111	6068.161
6067.721	6068.121
6067.761	6068.111
6067.121	6068.761
6067.161	6068.721

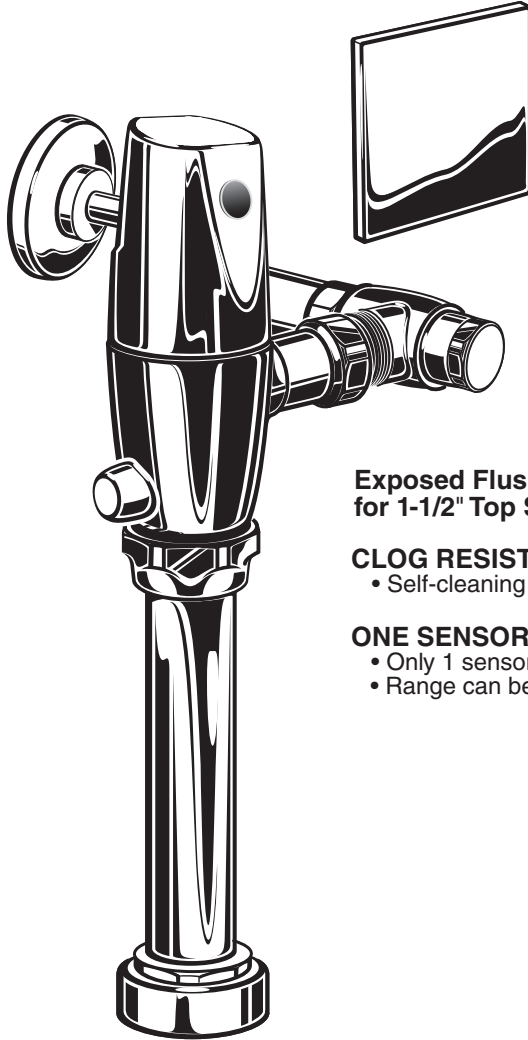

**Exposed Flushometer  
for 1-1/2" Top Spud Bowls**

#### **CLOG RESISTANT**

- Self-cleaning piston valve prevents clogging and reduces maintenance.

#### **ONE SENSOR FITS ALL**

- Only 1 sensor for entire Selectronic™ line of faucets, urinals, and flush valves.
- Range can be adjusted manually or with optional remote control.

Certified to comply with ASME A112.19.2M  
© 2011 AS America, Inc.

M965219 REV. 1.6

*American Standard*

**NOTE TO INSTALLER: Please give this manual to the customer after installation.**

To learn more about American Standard Faucets visit our website at: [www.americanstandard-us.com](http://www.americanstandard-us.com)  
or U.S. customer's e-mail us at: [faucetsupport@americanstandard.com](mailto:faucetsupport@americanstandard.com)

**For Parts, Service, Warranty or other Assistance,**  
please call **1-800-442-1902 (In Canada: 1-800-387-0369)**  
(In Toronto Area only: 1-905-3061093)

Thank you for selecting American-Standard...the benchmark of fine quality for over 100 years. To ensure that your installation proceeds smoothly--please read these instructions carefully before you begin.

## UNPACKING

All American Standard Products Are Water Tested At Our Factory. Some Residual Water May Remain In The Valve During Shipping.

1. Remove the Flush Valve items from the carton. The illustration below shows all items after they have been removed from the carton. Some items may be packaged partially assembled to other items.

- |                                  |                                      |
|----------------------------------|--------------------------------------|
| 1. Flush Valve Assembly          | 8. Supply Stop                       |
| 2. Down Tube and Vacuum Breaker  | 9. Installation Instructions         |
| 3. Spud Coupling Nut and Washers | 10. Front Panel                      |
| 4. Spud Flange                   | 11. Power Supply                     |
| 5. Sweat Solder Adapter          | 12. 10' Extension Cable for Multi-AC |
| 6. Cover Tube                    | 13. Cable Extension, 27"             |
| 7. Wall Escutcheon               | 14. Y Connector                      |

### CARE INSTRUCTIONS:

**DO: SIMPLY RINSE THE PRODUCT CLEAN WITH CLEAR WATER. DRY WITH A SOFT COTTON FLANNEL CLOTH.**

**DO NOT: DO NOT CLEAN THE PRODUCT WITH SOAPS, ACID, POLISH, ABRASIVES, HARSH CLEANERS, OR A CLOTH WITH A COARSE SURFACE.**

**DO NOT REMOVE PROTECTIVE FILM FROM SENSOR EYE UNTIL INSTALLATION IS COMPLETE.**

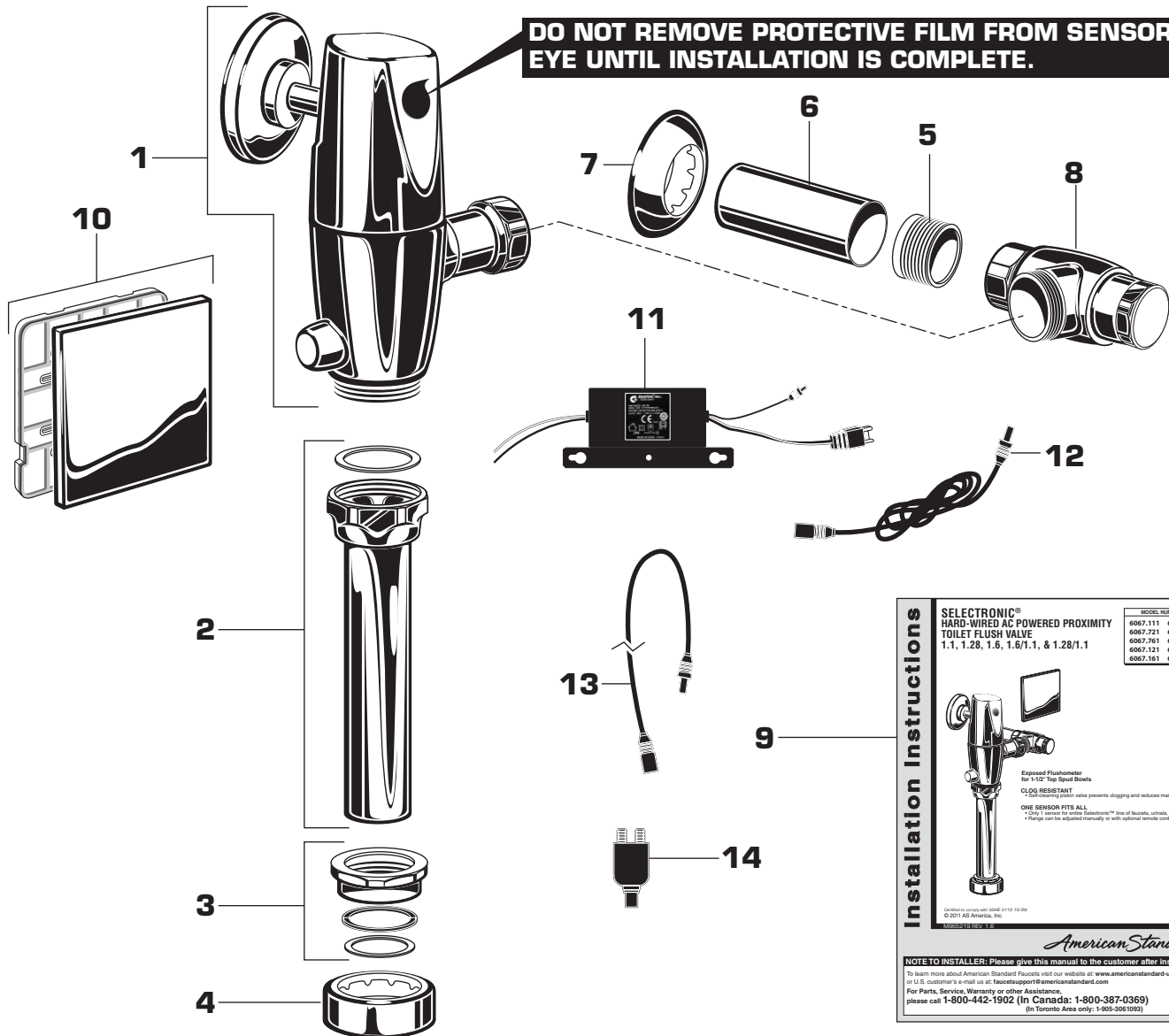

**Installation Instructions**

**SELECTRONIC®**  
**HARD-WIRED AC POWERED PROXIMITY**  
**TOILET FLUSH VALVE**  
 1.1, 1.28, 1.6, 1.6/1.1, & 1.28/1.1

MODEL NUMBERS	
6067.111	6068.161
6067.221	6068.121
6067.701	6068.111
6067.121	6068.701
6067.161	6068.721

Exposed Flushmeter for 5-1/2" Top Spud Bowls

**CLOG RESISTANT**  
 \*Self-cleaning piston valve prevents clogging and reduces maintenance.

**ONE SENSOR FITS ALL**  
 \*Fits all Selectronic™ line of toilets, urinals, and flush valves.  
 \*Hinge can be adjusted manually or with optional remote control.

*American Standard*

**NOTE TO INSTALLER: Please give this manual to the customer after installation.**

To learn more about American Standard Faucets visit our website at [www.americanstandardusa.com](http://www.americanstandardusa.com) or U.S. customer's e-mail us at [faucet-support@americanstandard.com](mailto:faucet-support@americanstandard.com)

For Parts, Service, Warranty or other Assistance, please call 1-800-442-1902 (In Canada: 1-800-387-0369) (In Toronto Area only: 1-905-306-1093)

©2011 AS America, Inc. M965219 REV. 1.0

**Fig. 1**  
**Roughing-in Dimensions**

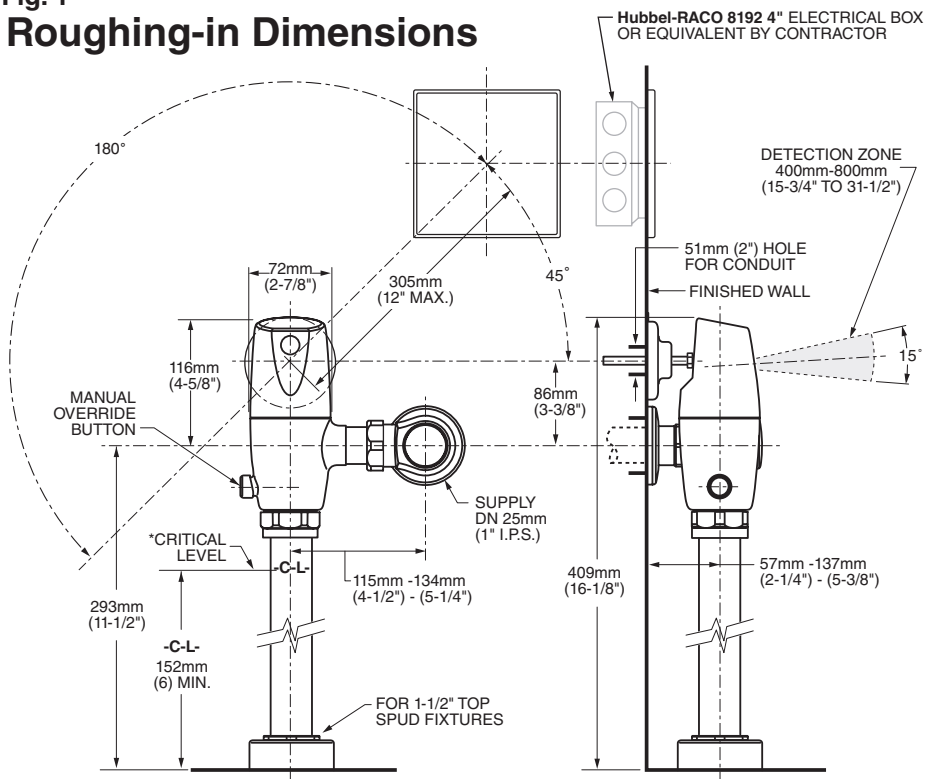

\*Note: The Critical Line (-C-L) on Vacuum Breaker must typically be 6" (152mm) above fixture. Consult Codes for details.

**GENERAL DESCRIPTION:**

**SELECTRONIC™  
PROXIMITY TOILET  
FLUSH VALVE**

**Exposed Flushometer  
for 1-1/2" Top Spud Fixtures**

Exclusive, self cleaning piston-type flush valve with proximity operation and manual override. Operates on AC power. Recommended operating pressure 25psi (flowing) to 80 psi (static). Can install left or right-handed. Detection Zone can also be adjusted manually, or with optional remote control.

**Right or Left Hand Installation**

See (Section 7) for converting Flush Valve to Left Hand Installation.

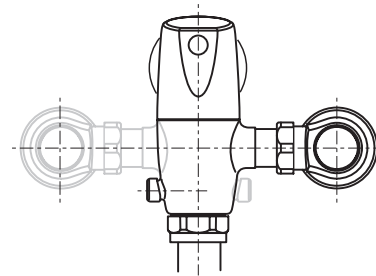

**RECOMMENDED TOOLS; Fig. 2**

1. Teflon Tape
2. Flat Blade Screwdriver
3. Adjustable Wrench
4. Tape Measure
5. Hacksaw
6. Tubing Cutter
7. File
8. For Sweat Connection; Solder and Torch
9. 2.5mm Hex Wrench
10. 1.5mm Hex Wrench

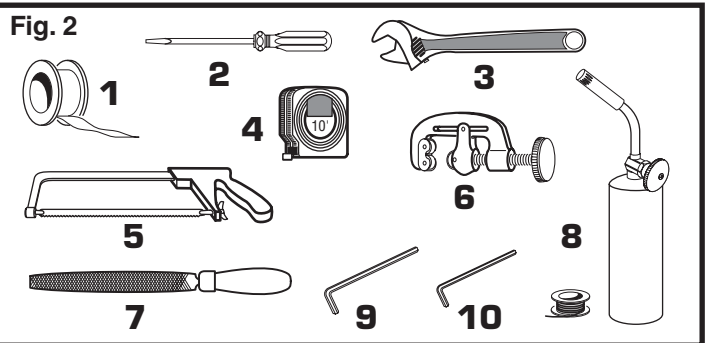

**PRIOR TO INSTALLATION**

**Note:** Prior to installing the Selectronic™ Flush Valve the following items must be installed.

1. Water Closet
2. Drain line
3. Water supply line

**IMPORTANT:**

- All plumbing and electrical wiring must be installed in accordance with applicable codes, regulations and standards.
- The use of water hammer arrestors is strongly recommended for commercial applications. All piping behind the walls should be properly secured and fastened.
- Water supply lines must be sized to provide an adequate volume of water for each fixture.

- Flush all water lines prior to operation (See Step 6). Dirt and debris can cause flush valve to run continuously.
- **With the exception of Supply Stop Inlet, DO NOT use pipe sealant or plumbing grease on any valve component or coupling!**
- Protect the chrome or special finish on the Flushometer. DO NOT USE toothed tools on finished surfaces to install or service these valves. Also see "Care and Cleaning" section of this manual.
- This product contains mechanical and/or electrical components that are subject to normal wear. These components should be checked on a regular basis and replaced as needed to maintain the valve's performance.

# INSTALLATION

## 1 INSTALL ELECTRICAL BOX ASSEMBLY; Fig. 3

1. Drill a 2" diameter hole in the finished wall for the conduit tube from the flush valve at the dimension shown. **Fig.3.**
  2. Cut a 127x127mm (5"x 5") opening in finished wall for ELECTRICAL BOX (1) (not supplied) at the dimensions shown.
  3. Feed SENSOR CABLE (2) through wall opening and out 2" diameter hole.
- Important: Make sure the smaller end of the SENSOR CABLE (2) goes through the 2" diameter hole. Detail A.**
4. Install ELECTRICAL BOX (1).
- Note: The ELECTRICAL BOX (1) can be installed in any location along the 180° arc.**

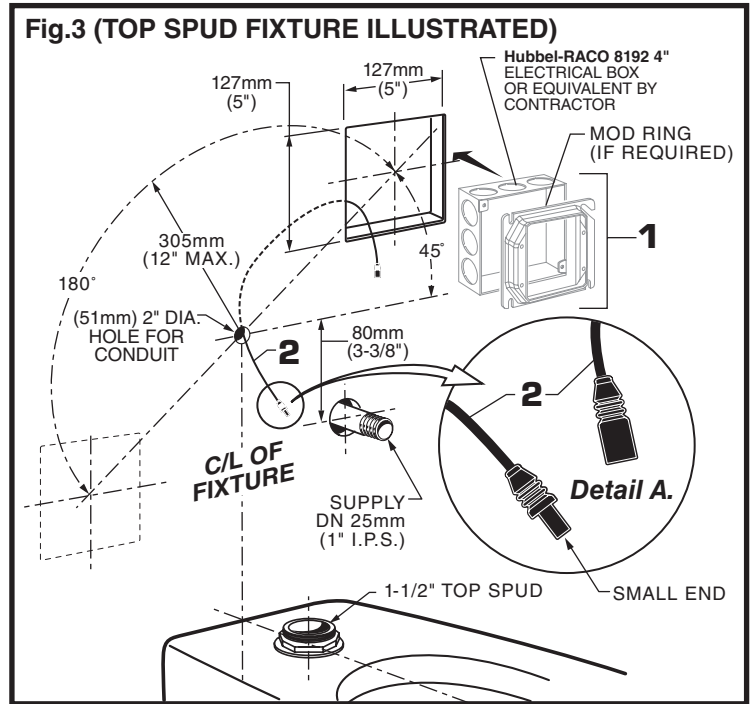

## 2 INSTALL POWER SUPPLY AND MAKE ELECTRICAL CONNECTIONS; Fig. 4

**CAUTION** Turn power supply OFF before making connections

1. Mount POWER SUPPLY (1) into ELECTRICAL BOX (2). Connect White and Black power connections to POWER SUPPLY (1).
2. Connect the 27" CABLE EXTENSION (3) to the POWER SUPPLY CABLE (1a). **Fig. 4a.**
3. After POWER SUPPLY (1) is installed and wire connections are completed install the FRONT PANEL FRAME (4) to the ELECTRICAL BOX (2). **Fig. 4b.**
4. Install the two Tabs on the back side of the FRONT PANEL (5) into the two Slots located on the top edge of the FRONT PANEL FRAME (4). Push on bottom until it snaps into place. **Fig. 4b.**

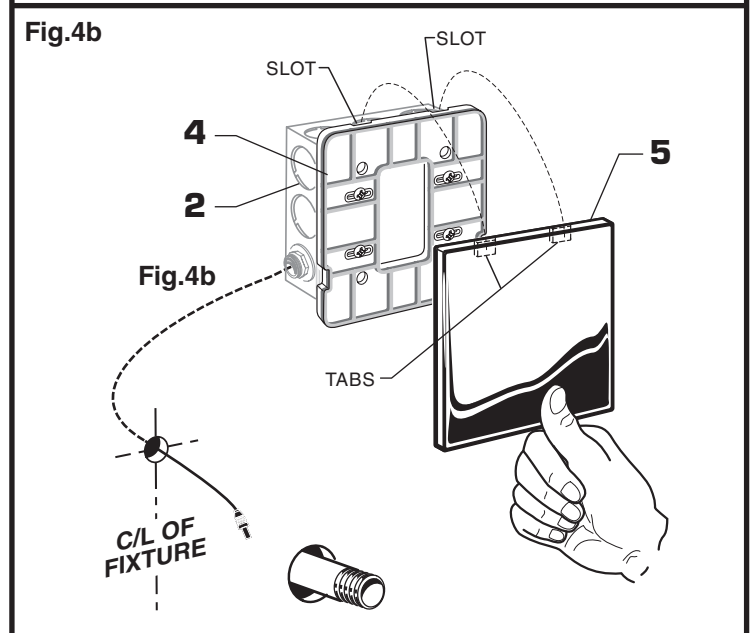
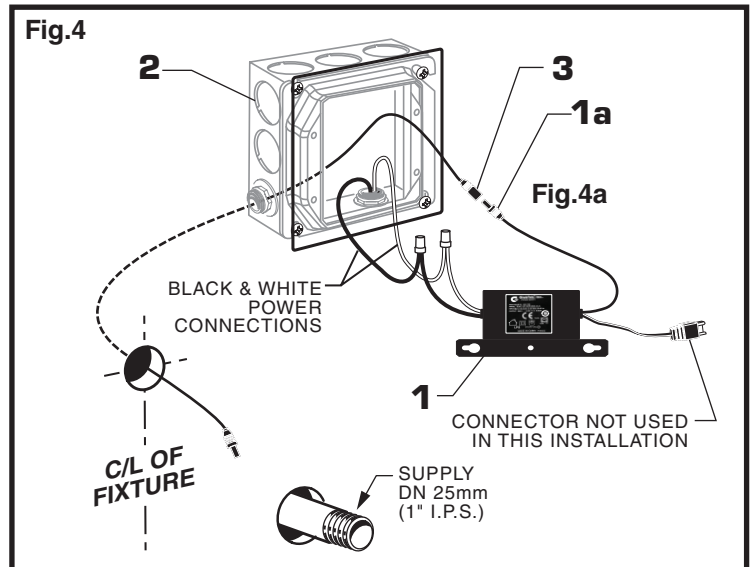
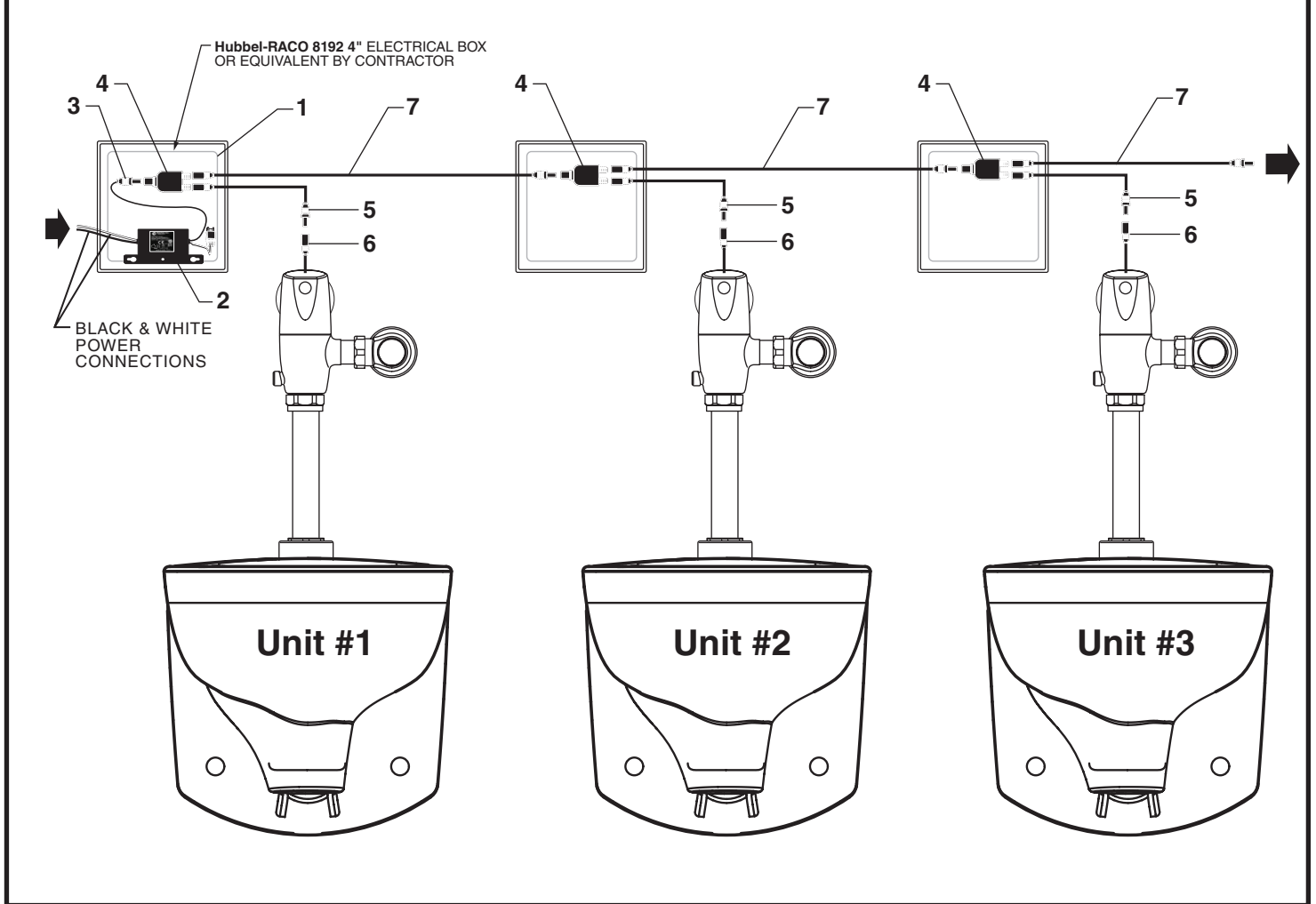

Fig.4c



### 3 FOR AC-VERSION (MULTI HOOK-UP); Fig. 4c

1. Contractor to supply ELECTRICAL BOX (1). Mount POWER SUPPLY (2) into ELECTRICAL BOX (1). Connect White and Black power connections to POWER SUPPLY.
2. Connect the POWER CABLE (3) from the power supply to the SPLITTER (4).
3. Connect the 27" CABLE EXTENSION (5) to the SPLITTER (4) and to the SENSOR CABLE (6) from the flush valve.
4. Connect the 10' MULTI EXTENSION POWER CABLE (7) to the SPLITTER (4) and to the end of the next SPLITTER and so on.
5. Repeat steps 3 and 4 as necessary for additional Multi-AC units required.

## 4 INSTALL THE SWEAT SOLDER ADAPTER; Fig. 5

**CAUTION** Turn water supplies off before beginning

**Note:** *Install Optional Sweat Solder Adapter (Supplied) for copper pipe supply line. Fig. 5.*

1. Measure the distance (A) from the finished wall to the center of the inlet spud on the fixture.
2. Cut the supply pipe 1-1/4" (A-B=C) shorter than the measurement taken in Step 1. File any rough edges off the end of the supply pipe.
3. Clean the end of the supply pipe. Push the threaded Adapter on until it is seated against the internal stop. Sweat the Adapter to the pipe.

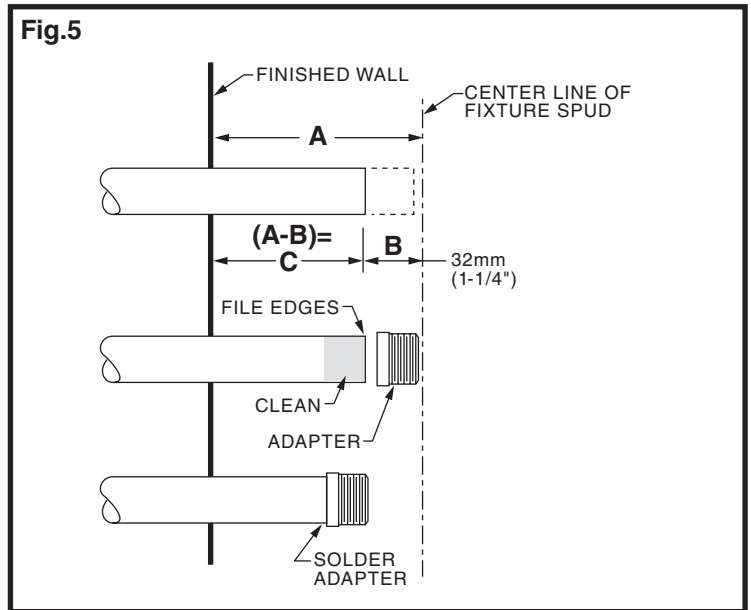

## 5 INSTALL COVER TUBE, WALL ESCUTCHEON and SUPPLY STOP; Fig. 6

1. Measure from finished wall to first thread of Adapter or threaded supply pipe (dimension "X"). Cut COVER TUBE (1) to length (X). Apply Teflon Tape to the threaded end of the Adapter or supply pipe. **Fig. 6a.**
2. Push the COVER TUBE (1) into the WALL ESCUTCHEON (2). Slide both onto the SUPPLY PIPE (3). **Fig. 6b.**
3. Push the COVER TUBE (1) in to expose the threads of the supply pipe. Fig. 4c. With a wrench thread the SUPPLY STOP (4) onto the SUPPLY PIPE (3). Align and tighten. **Fig. 6c.**
4. Pull COVER TUBE (1) against SUPPLY STOP (4) and push WALL ESCUTCHEON (2) against finished wall.

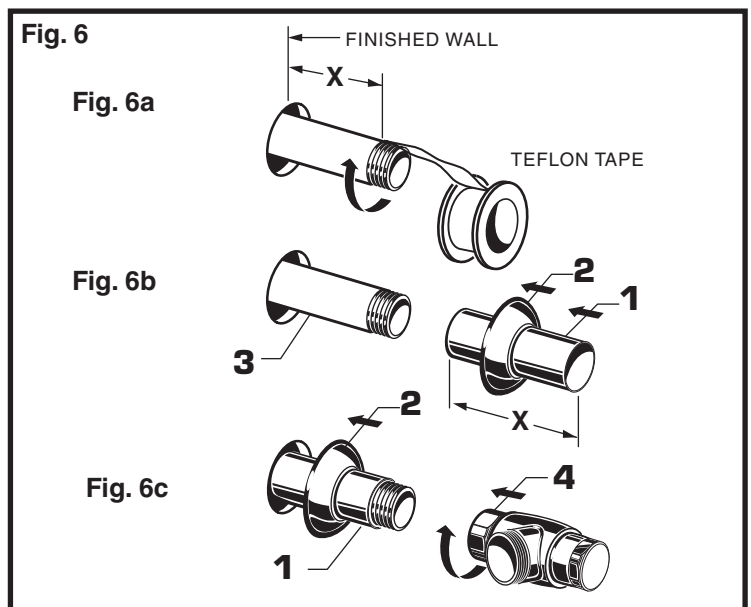

## 6 INSTALL DOWN TUBE AND VACUUM BREAKER; Fig. 7

1. Place the SPUD FLANGE (1) over the spud on the Fixture.
2. Thread SPUD COUPLING NUT (2) onto Spud. Make sure SEAL WASHER (3) and FRICTION WASHER (4) are installed. Do not tighten fully.
3. Insert the DOWN TUBE (5) into the SPUD COUPLING NUT (2) and push it down.

**Note:** *If cutting Down Tube (5) to size, note that Critical Line (CIL) on Vacuum Breaker must typically be 6" (152mm) above fixture. Consult Code for details.*

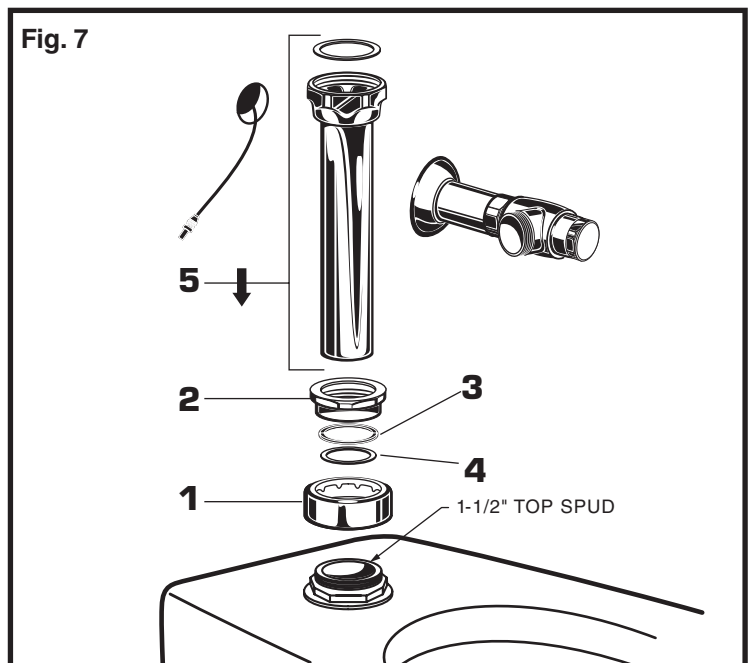

## 7 FLUSH OUT SUPPLY LINES; Fig. 8

1. Remove COVER (1) from SUPPLY STOP (2).
2. With a flat blade screwdriver open SUPPLY STOP (2).
3. Turn on water supply to flush line of any debris or sediment.
4. Close SUPPLY STOP (2) and replace COVER (1).

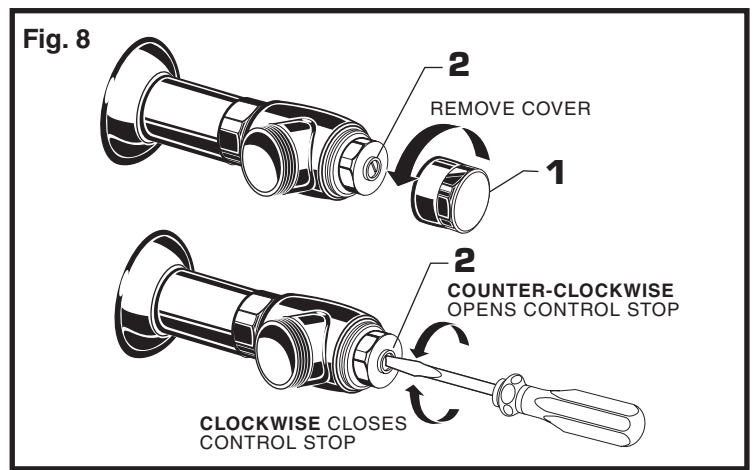

## 8 LEFT OR RIGHT HAND INSTALLATION; Fig. 9

The UNIT is shipped with the inlet flange on the right side. If needed, the orientation can be reversed by following the steps below.

1. Loosen SET SCREW (1) with 2.5mm Hex Wrench (4) in back of top half of FLUSH VALVE (2). Fig. 9a.
2. Rotate COVER (2) to the right and pull off. Fig. 9b.
3. Rotate bottom half of FLUSH VALVE (3) 180°. Fig. 9b.
4. Replace COVER (2) and rotate until key engages then tighten SET SCREW (1). Fig. 9c, 9d.

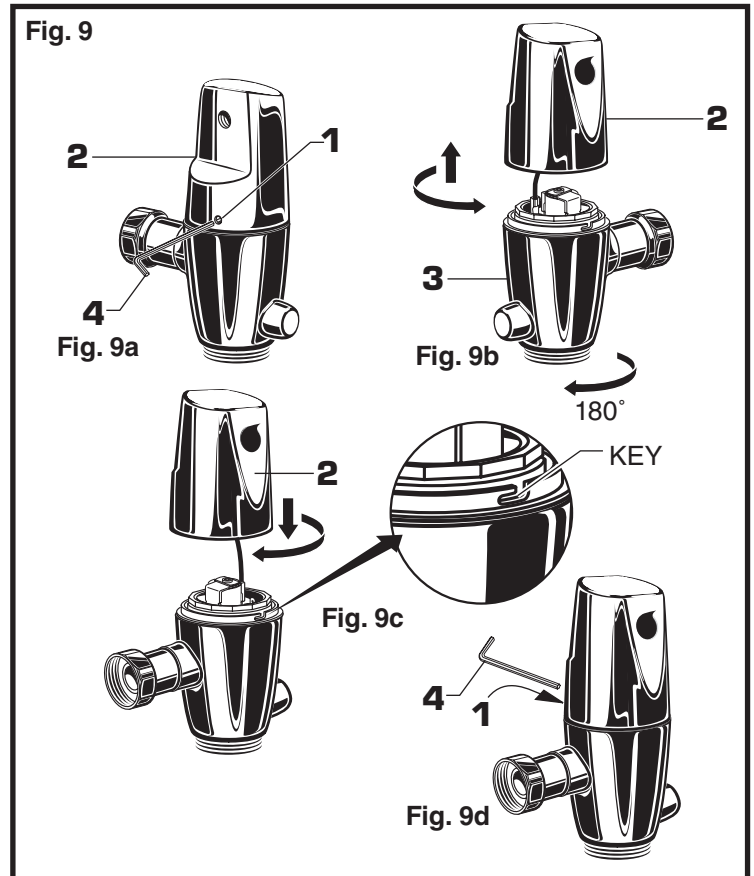

## 9 INSTALL FLUSH VALVE; Fig. 10a

1. Insert the side INLET FLANGE (1) on the FLUSH VALVE (2) into the SUPPLY STOP (3). Lubricate the INLET FLANGE O-RING (4) with water if necessary. Lightly tighten COUPLING NUT (5). Fig. 10a.  
**Important: Do not use lubricants (other than water) or any type of thread sealing paste or tape.**

2. Align the FLUSH VALVE (2) (Fig. 10b) directly above the DOWN TUBE (7) and VACUUM BREAKER COUPLING NUT (6). Make sure that GASKET (10) is installed.

**Note: There is a +13mm, -6mm (+1/2, -1/4) tolerance for the 121mm (4-3/4) dimension. Fig. 10b.**

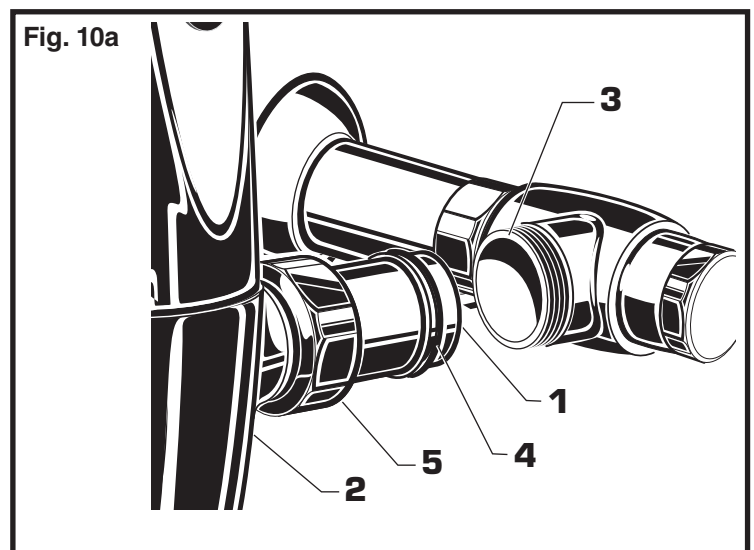

## 10 INSTALL FLUSH VALVE; Fig. 10b

1. Pull the DOWN TUBE (7) up to meet the threaded FLUSH VALVE CONNECTION (8) and hand tighten the VACUUM BREAKER COUPLING NUT (6). Align all components of the flush valve assembly. Fig. 10b.
2. Lightly tighten the COUPLING NUT (5) connection first, then the VACUUM BREAKER COUPLING NUT (6) and finally the SPUD COUPLING NUT (9). Once aligned correctly, use a wrench to tighten couplings to make water tight connections. Fig. 10b.

## 11 INSTALL CONDUIT, ESCUTCHEON AND SENSOR CABLE; Fig. 11

1. Remove COVER ASSEMBLY (1). See step seven to remove the COVER ASSEMBLY (1). Fig. 9a.
2. Thread CONDUIT (2) into COVER ASSEMBLY (1) and secure by tightening LOCK NUT (3). Fig. 11a.
3. Slide ESCUTCHEON (4) onto CONDUIT (2). Fig. 11b.
4. Feed the 27" CABLE EXTENSION (5) thru CONDUIT (2) and connect the CABLE END (5a) to the SENSOR CABLE (7) in the COVER ASSEMBLY (1). Fig. 11b. Tuck SENSOR CABLE (5) into COVER ASSEMBLY (1).
5. Insert CONDUIT (2) into hole in wall while replacing COVER ASSEMBLY (1). Rotate until key engages then tighten SET SCREW (1). Fig. 9c, 9d.  
**Note: If space between wall and valve are too tight, the CONDUIT (2) will have to be removed and replaced after the COVER ASSEMBLY (1) is installed.**
6. Slide ESCUTCHEON (4) tight against finished wall and secure by tightening SET SCREW (7). Fig. 11b.

## 12 ADJUST SUPPLY STOP; Fig. 12

**IMPORTANT: To avoid overflowing, the SUPPLY STOP (3) must never be opened to the point where the flow from the valve exceeds the flow capacity of the fixture. The fixture must be able to handle a continuous flow in case of a flush valve failure.**

1. After installation is complete, peel off the PROTECTIVE FILM (1) from the sensor. Standing to one side, block the sensor with your hand for 10 seconds.  
**Remove your hand and listen for audible "click" from within the valve.**
2. Remove COVER (2) from SUPPLY STOP (3). Turn on water supply 1/4 turn to 1/2 turn (CCW) and test for leaks.  
**Note: Unit may flush for approximately 5 to 10 sec. when water is first turned on. If flow persists, turn water off and repeat step #1 above.**
3. Actuate the FLUSH VALVE:
  - A) Cover sensor with hand for 10 seconds.  
**NOTE: Stand outside of sensor detection area.**
  - B) Remove hand from in front of the sensor; unit will flush in approximately 3 seconds.
4. Adjust SUPPLY STOP (3) after each flush until the stated flush volume is achieved, no splashing occurs and the fixture is properly cleansed.
5. When adjustment is complete, replace COVER (2) and tighten to ensure vandal-resistance.

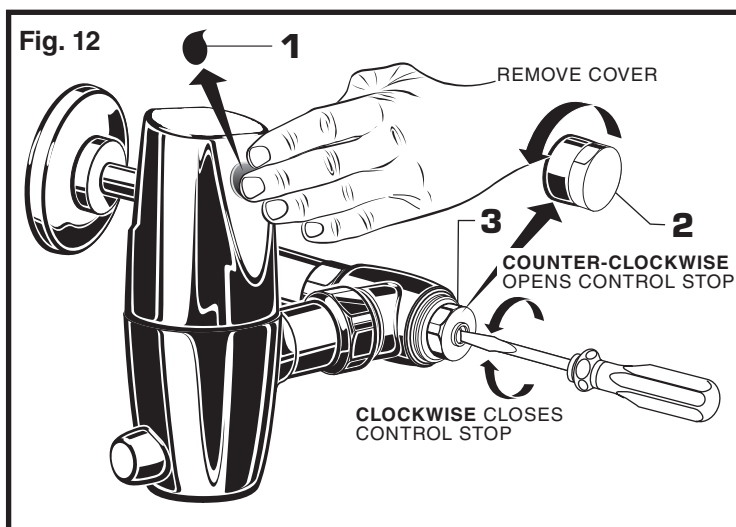
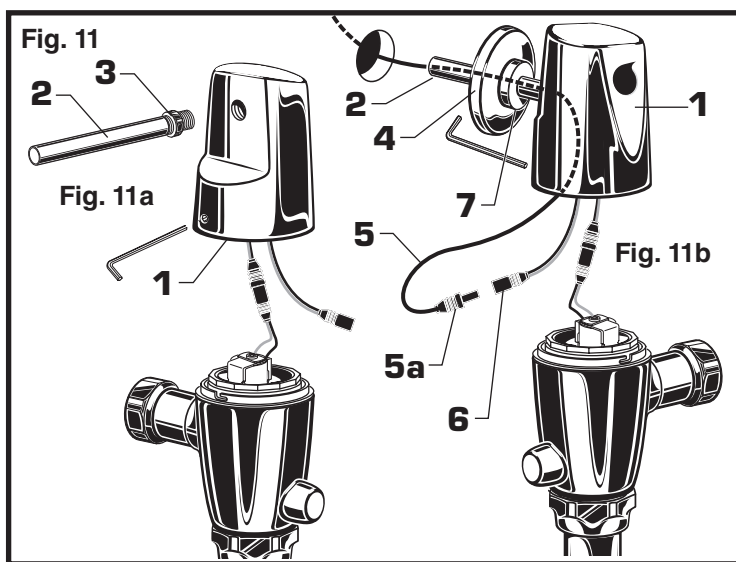
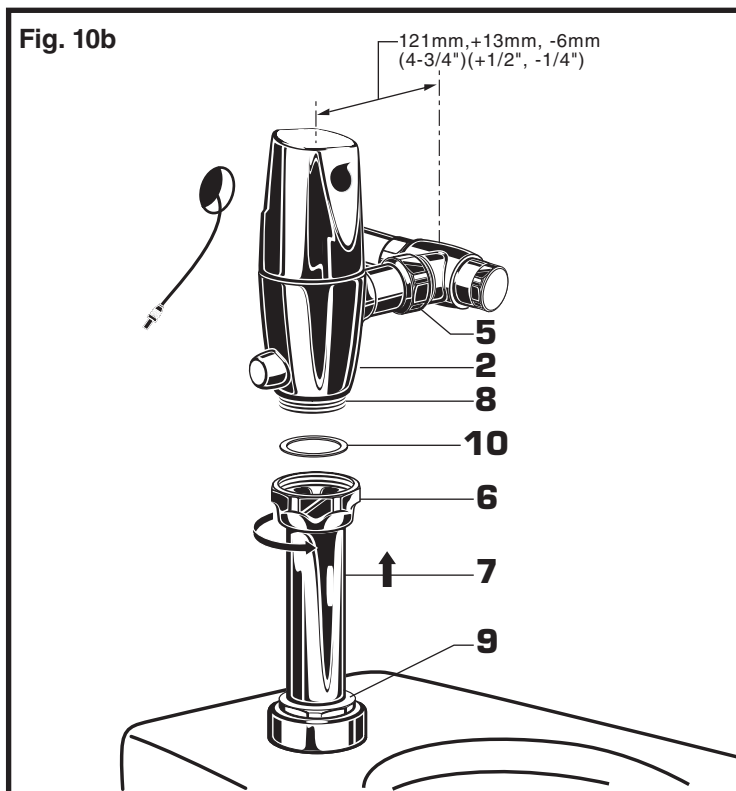



## 13 HOW TO SET DETECTION RANGE (If Required) ; Fig. 13 & 14

**Note:** *The detection distance is preset and is ideal for most installations. Should an adjustment be required follow the steps below.*

1. To remove the FRONT PANEL (1), insert WIRE KEY (2) (supplied) into the two holes located at the bottom of the FRONT PANEL (1). Push the WIRE KEY (2) up until it releases the bottom clips. Pull the bottom edge away and lift the FRONT PANEL (1) off. Fig. 13a.
2. Pull out the POWER SUPPLY CONNECTOR (3). Disconnect and then reconnect the the POWER SUPPLY CONNECTOR (3). Fig. 13b.  
**Note:** *You will have 5 seconds after connecting both connectors to enter the program code.*
3. While the SENSOR CONTROL LED (6) is blinking slowly, place your hand 1 to 2 in. (30-50mm.) in front of the sensor. Fig. 14a.
4. When the LED (6) stops blinking and stays "ON", move your hand to the desired position from sensor (detection zone, 1-1/2" to 31", 38 to 787mm ) and hold in place until the LED (6) begins to blink again. Fig. 14b.  
**Note:** *Detection Zone is 1-1/2" to 31", 38 to 787mm from sensor.*
5. Once the SENSOR CONTROL LED (6) begins to blink again, remove your hand from the detection zone. When the flashing stops, the detection distance is set.
6. Actuate the FLUSH VALVE:
  - A) Cover sensor with hand for 10 seconds. **NOTE:** **Stand outside of sensor detection area.**
  - B) Remove hand from in front of the sensor; unit will flush in approximately 3 seconds.

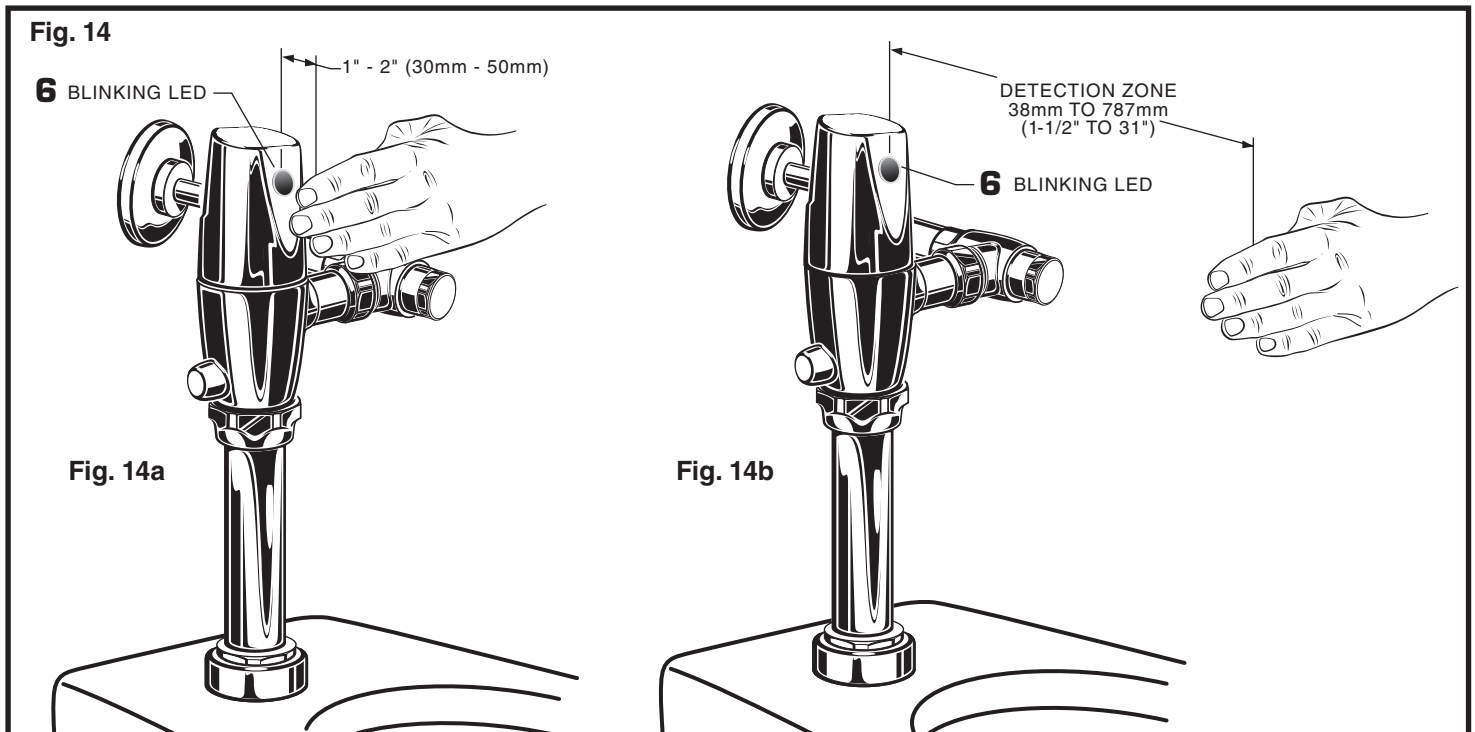
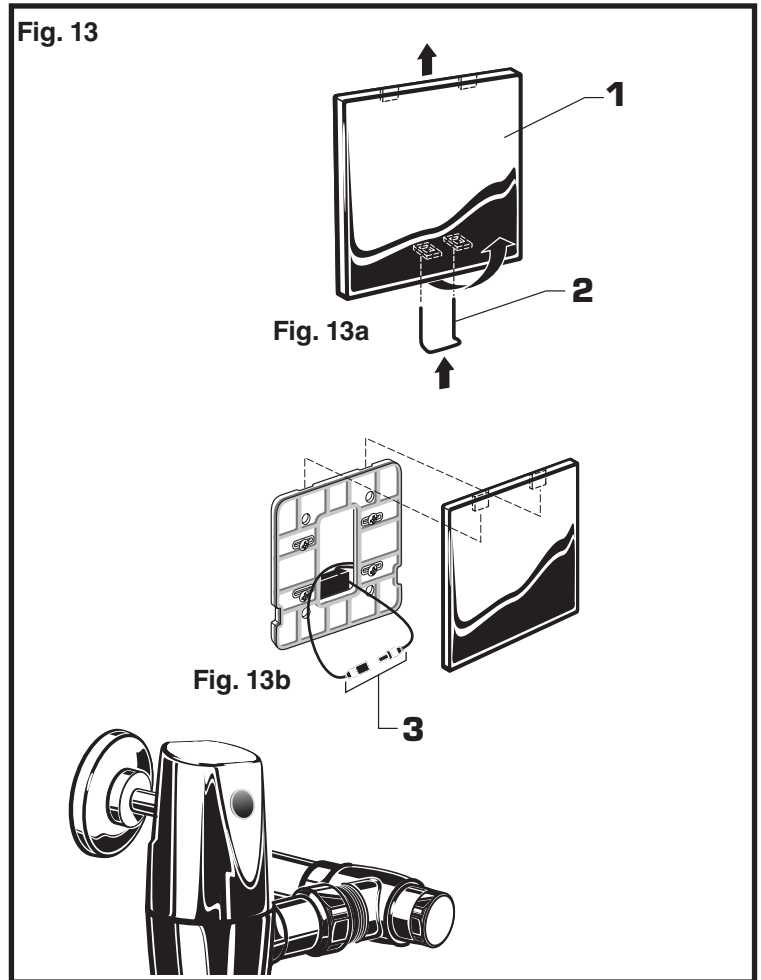

# TROUBLESHOOTING FLOW CHARTS

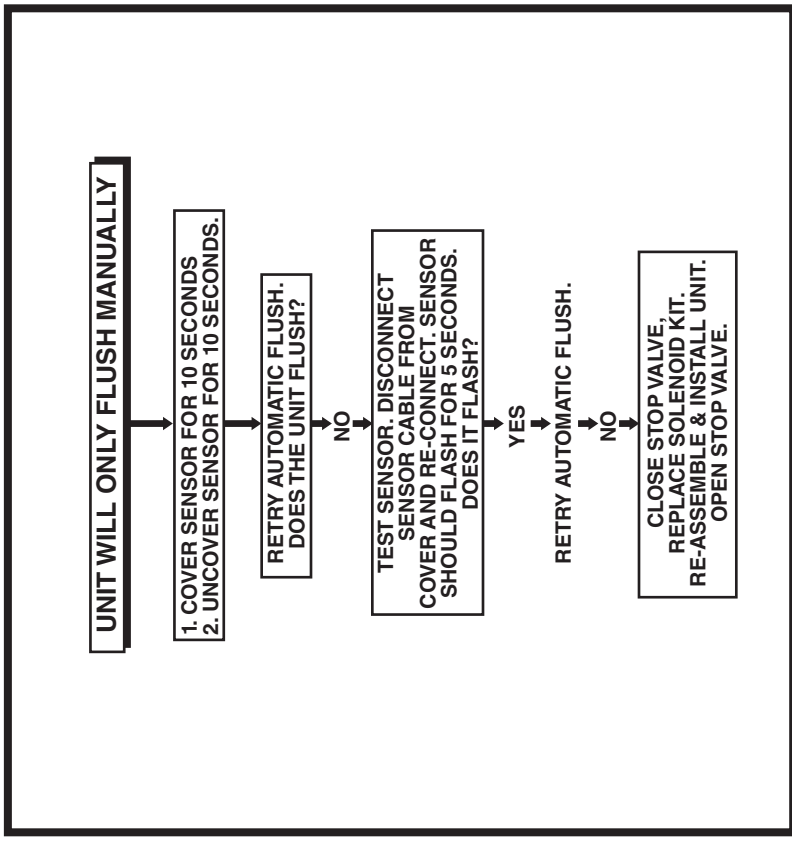
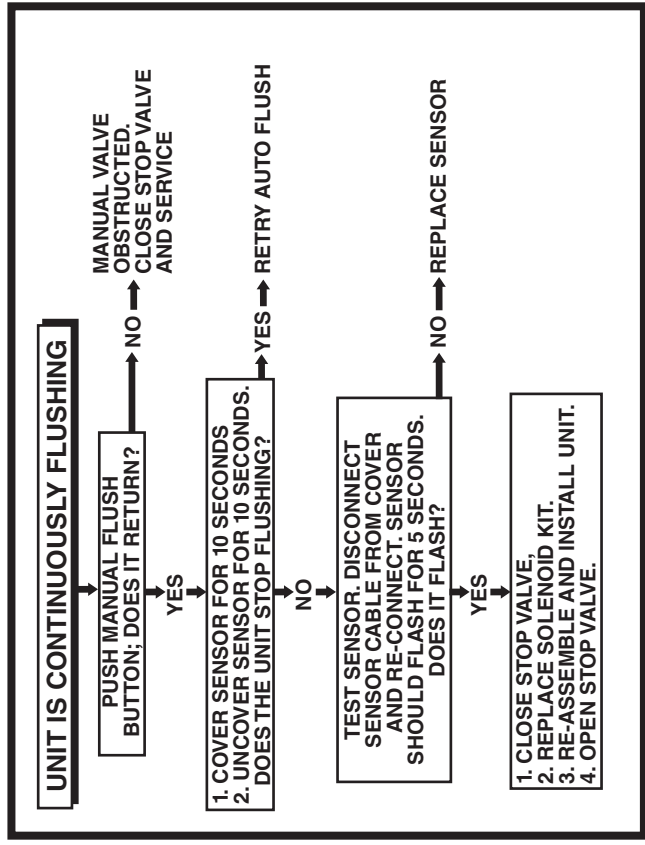
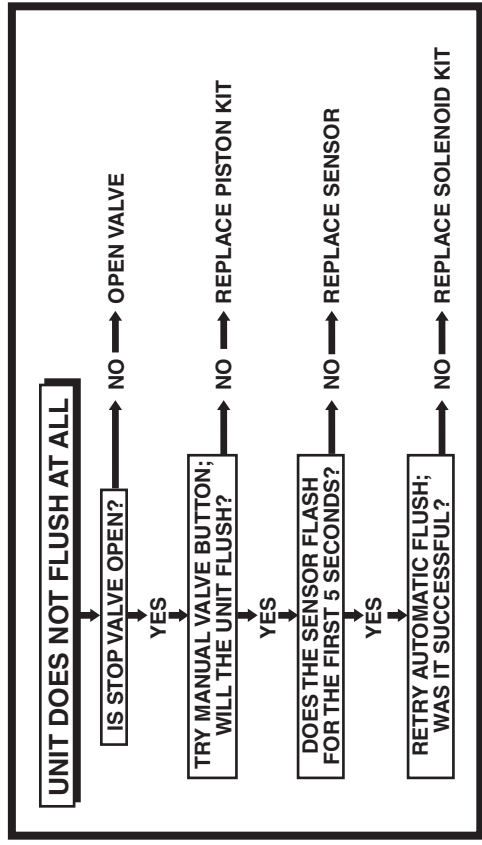



**HOT LINE FOR HELP**

For toll-free information and answers to your questions, call:  
 1 (800) 442-1902  
 Weekdays 8:00 a.m. to 6:00 p.m. EST  
 IN MEXICO 01-800-839-1200

IN CANADA 1-800-387-0369 (TORONTO 1-905-306-1093)  
 Weekdays 8:00 a.m. to 7:00 p.m. EST

Product names listed herein are trademarks of AS America, Inc.

**SELECTRONIC®  
HARD-WIRED AC POWERED PROXIMITY  
TOILET FLUSH VALVE  
1.1, 1.28, 1.6, 1.6/1.1 & 1.28/1.1**

**PRODUCT NUMBERS**

<b>6067.111</b>	<b>6068.161</b>
<b>6067.721</b>	<b>6068.121</b>
<b>6067.761</b>	<b>6068.111</b>
<b>6067.121</b>	<b>6068.761</b>
<b>6067.161</b>	<b>6068.721</b>

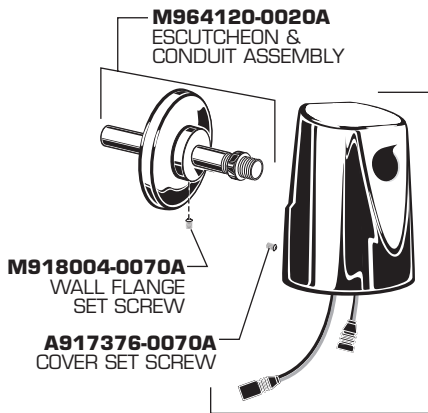

- M964107-0024000A**  
COVER ASSEMBLY FOR  
FLUSH VALVE WITH 1.6/1.1 gpf
- M964107-0025000A**  
COVER ASSEMBLY FOR  
FLUSH VALVE WITH 1.28/1.1 gpf
- M964107-0021600A**  
COVER ASSEMBLY FOR  
FLUSH VALVE WITH 1.6 gpf
- M964107-0021280A**  
COVER ASSEMBLY FOR  
FLUSH VALVE WITH 1.28 gpf
- M964107-0021100A**  
COVER ASSEMBLY FOR  
FLUSH VALVE WITH 1.1 gpf

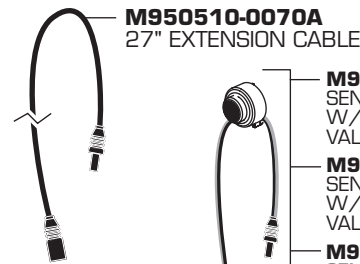
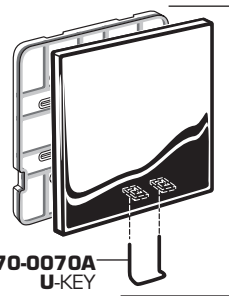

- M950319-0071600A**  
SENSOR ASSEMBLY  
W/MTG. KIT. FOR FLUSH  
VALVE WITH 1.6 gpf
- M950319-0071280A**  
SENSOR ASSEMBLY  
W/MTG. KIT. FOR FLUSH  
VALVE WITH 1.28 gpf
- M950319-0074000A**  
SENSOR ASSEMBLY  
W/MTG. KIT. FOR FLUSH  
VALVE WITH 1.6/1.1gpf
- M950319-0075000A**  
SENSOR ASSEMBLY  
W/MTG. KIT. FOR FLUSH  
VALVE WITH 1.28/1.1gpf
- M950319-0071100A**  
SENSOR ASSEMBLY  
W/MTG. KIT. FOR FLUSH  
VALVE WITH 1.1gpf



- OPTIONAL ADJUSTABLE TAILPIECE  
(Purchased Separately)
- M962836-0020A** (8-1/4" to 9-1/4" Rough-in)
- M962835-0020A** (7-1/4" to 8-1/4" Rough-in)
- M962834-0020A** (6-1/4" to 7-1/4" Rough-in)
- M962833-0020A** (5-1/4" to 6-1/4" Rough-in)

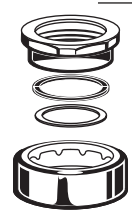
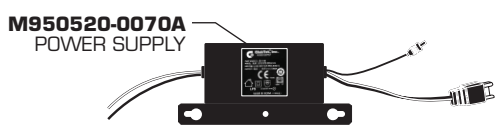
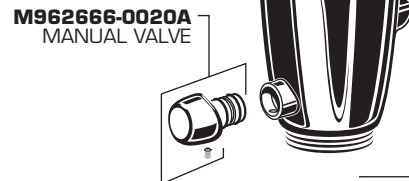

**M952269-0020A**  
ESCUTCHEON KIT

**HOT LINE FOR HELP**  
For toll-free information and answers to your questions, call:  
1 (800) 442-1902  
Weekdays 8:00 a.m. to 6:00 p.m. EST  
IN MEXICO 01-800-839-12-00  
IN CANADA 1-800-387-0369 (TORONTO 1-905-306-1093)  
Weekdays 8:00 a.m. to 7:00 p.m. EST

Product names listed herein are trademarks of AS America, Inc.  
© American Standard Inc. 2012