



Lavatory Faucet

S-240 Series

INSTALLATION, OPERATION AND SERVICE INSTRUCTIONS

Faucet meets ANSI A112.18.1M Flow rate: 2.2 gpm (8.3 L/min)

Caution: Be sure to turn off hot and cold water supplies before installing or servicing faucet.

INSTALLATION:

1. Push faucet supplies through holes in sink. Secure faucet to sink by tightening flange nuts (KN-116) from underside. (If sink or counter surface is uneven, use putty or sealant to make proper seal under base.)
2. Connect hot supply to left tube and cold supply to right tube using appropriate connectors.
3. Pop-up drain installation:
 - a) Remove pop-up plug, tail piece and flange from the drain body. Make sure that locknut is threaded all the way down onto the body with flat friction washer in middle and beveled washer on top.
 - b) Apply plumbers putty or sealant to bottom of flange.
 - c) Install drain body through drain opening in lavatory and screw flange onto the drain body making sure that the threads are completely engaged for proper sealing and strength of the connection. Apply joint compound to all threaded parts to insure proper seal. Apply putty or teflon tape to tail piece before attaching to drain body.
 - d) Tighten locknut to compress the beveled flange evenly across the bottom of the drain opening taking care not to over tighten the locknut, causing damage to the lavatory.
 - e) Remove one of two ball washers from inside the threaded cavity. Insert pop-up plug and pivot rod into body. Add one ball washer (the second ball washer should remain inside the body) to the outside of the ball. Tighten the retaining nut until the ball is seated on the internal and external ball washers. Note: The pop-up plug can be installed either in the removable or non-removable position, depending on the location of the hole located in the guide at the bottom of the plug.
 - f) Slide the pivot rod through one side of the spring clip, then the appropriate adjustment hole and then other side of the spring clip.
 - g) Insert lift rod through faucet housing and the top of the lift strap and secure it in place by tightening the screw. Note: To insure proper operation of lift rod and pop-up, some adjustment of the linkage may be required. There are two possible adjustment points: 1) lift strap to lift rod and 2) lift strap to pivot rod.
4. It is very important to thoroughly flush the supply lines to prevent foreign matter, i.e. copper chips, sand, stones, etc. from damaging the sealing surfaces of cartridge. Remove aerator and turn cold valve handle on to full cold position, open cold supply. Without closing, turn hot valve handle to full hot position and open hot supply. Let water run in hot only and cold only positions long enough to flush supply lines thoroughly. Shut off faucet and replace aerator. Check for leaks.

To replace cartridge (KN-113 or KN-114) in faucet with standard or LCT handles:

1. Remove plug button (T-33, T-33R or T-33B), loosen philip head screw (LN-121A) and remove handle (LN-140, LN-131 or LN-102).
2. Place wrench on cartridge hex nut (KN-113, KN-114). Turn

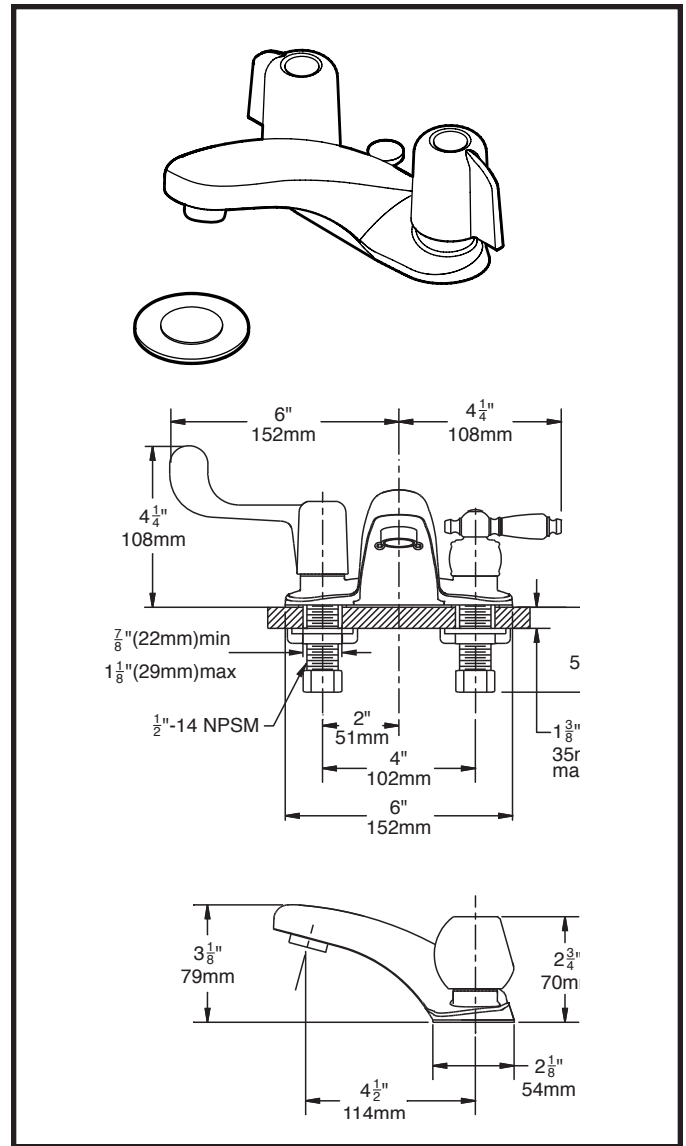

wrench counter clockwise until cartridge is removed.

3. Install new cartridge. Turn cartridge with wrench until cartridge does not turn easily then turn 1/4 or 1/2 turn further. Reassemble handle in reverse fashion.

To replace cartridge (KN-113 or KN-114) in faucet with LCF, LPO or LAM handles:

1. Loosen philip oval head screw (LN-134) and remove handle (LN-114).
2. Remove collar (LN-112) by turning counter clockwise, do not use wrench as this may damage the surface finish.
3. Place wrench on cartridge hex nut (KN-113, KN-114). Turn wrench counter clockwise until cartridge is removed.
4. Install new cartridge. Turn cartridge with wrench until cartridge does not turn easily then 1/4 or 1/2 turn further. Reassemble handle in reverse fashion.

- DF-30 Finial, handle
- KN-113 Valve cartridge (cold)
- KN-114 Valve cartridge (hot)
- KN-116 Flange nut (2)
- L-42 Nut (2)
- LN-15* Aerator
- LN-20 Gasket
- LN-100 Aerator (vandal resistant 0.5 gpm)
- LN-101 Aerator (vandal resistant)
- LN-102 Acrylic handle (2)
- LN-111* Lock ring (2)
- LN-112* Lever handle collar (2)
- LN-114* Handle lever
- LN-115 Bushing (2)
- LN-118 Supply body assembly
- LN-120* Shell
- LN-121A Phillips pan head screw (2)
- LN-131* ADA handle (2)
- LN-132A White lever insert (2)
- LN-132B Chrome lever insert (2)
- LN-133A Temperature indicator (red)
- LN-133B Temperature indicator (blue)
- LN-134* Oval Phillips head screw (2)
- LN-136 Clear lever insert (2)
- LN-139* Undercover plate
- LN-140 Lever handle (2)
- LN-177 Cross handle (2)
- RL-154* Pop-up drain assembly
- P-26 Grid drain assembly
- T-33* Plug button (plain)
- T-33B Plug button (blue)
- T-33R Plug button (red)

*For Decorative Finish Faucets add suffix to parts marked with an asterisk as follows:

Suffix BRS: Radiance® polished brass finish
 Suffix STN: Radiance® satin finish

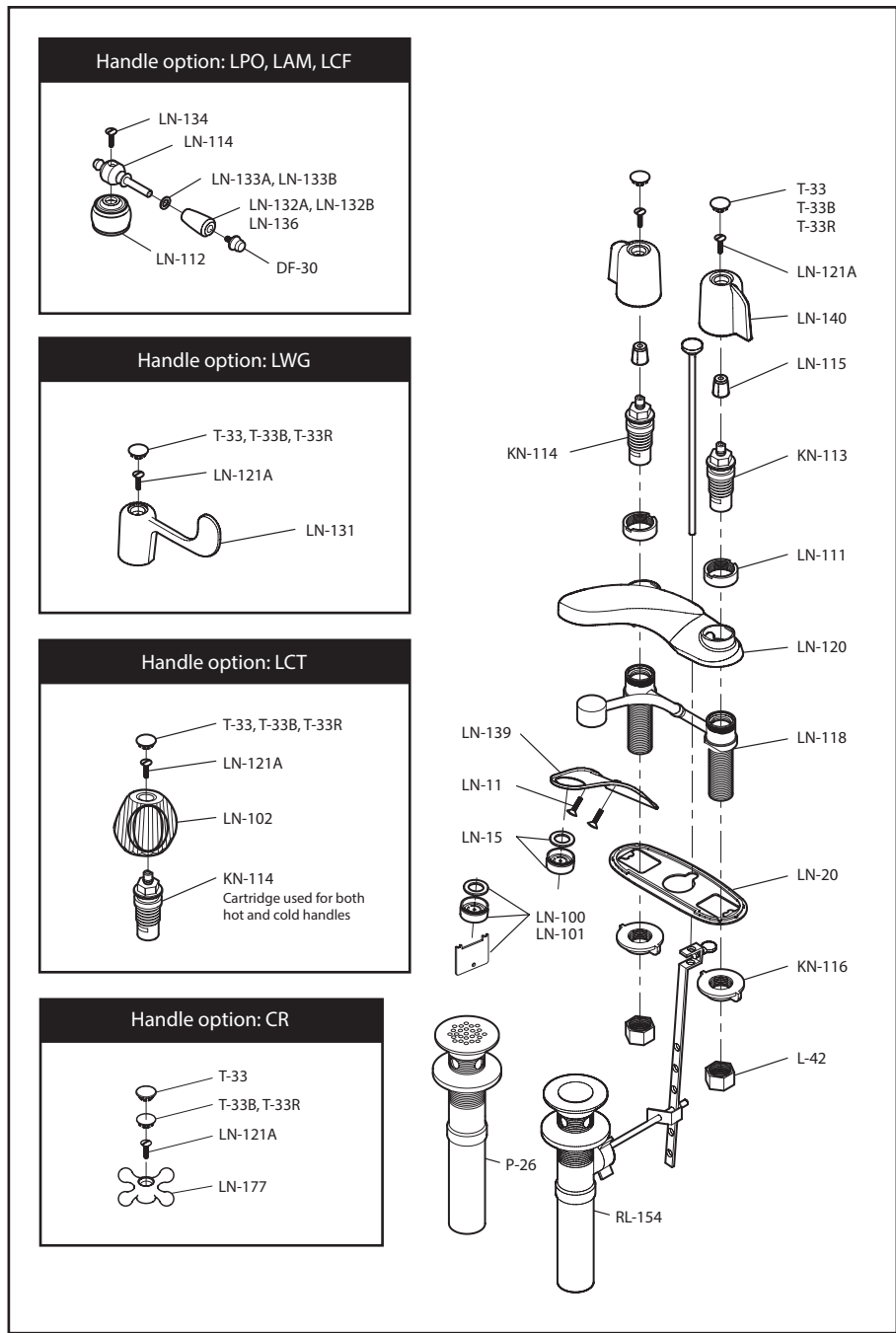

Lifetime Limited Warranty

Symmons warrants to the original consumer purchaser that any TEMPTROL® series* or SYMMETRIX® product will be free of defects in material and workmanship during normal domestic use for the life of your home. All other products and purchasers including industrial, commercial or business use are warranted for a period of 5 years from the date of purchase. At our option, we will either have you send the defective part or product prepaid to us for inspection, or we may elect to send you the replacement part or product without investigation. A replacement for any defective part will be supplied FREE OF CHARGE for installation by the purchaser. Defect or damage caused by the use of replacement parts other than Symmons Genuine Replacement Parts will void this warranty. This warranty excludes product damage due to installation error, product abuse, or product misuse whether performed by a contractor, service company or yourself. Symmons further warrants that any TEMPTROL or SYMMETRIX product will be leak free and drip free during normal domestic use for the life of your home. If the product should develop a leak or drip, Symmons will provide FREE OF CHARGE the parts necessary to return it to good working condition. Proof of purchase [original sales receipt] and a copy of the warranty registration card from the original consumer purchaser must accompany all warranty claims. This warranty is applicable only to Symmons TEMPTROL or SYMMETRIX products purchased after July 1, 1998 and shall be effective from the date of purchase as shown on the purchaser's receipt. Damage to the chrome and/or other decorative finishes on Symmons products may be a result of improper handling or abusive treatment. Finishes should only be cleaned with a soft, damp cloth or sponge. Use of polish, abrasive cleaners, solvents, or acid cleaners will damage the finish and void this warranty. There are no other express warranties on this product and ALL WARRANTIES OF MERCHANTABILITY AND OTHER IMPLIED WARRANTIES ARE LIMITED IN ACCORDANCE WITH APPLICABLE LAW. SYMMONS INDUSTRIES, INC., EXPRESSLY DISCLAIMS CONTINGENT LIABILITY AND CONSEQUENTIAL DAMAGE OF EVERY KIND. Since some states do not allow limitations on how long an implied warranty lasts or an exclusion or limitation of incidental or consequential damages the above limitation or exclusion may not be applicable. This warranty gives specific legal rights. Other rights may vary from state to state. To obtain warranty service, write to Symmons Industries, Inc., 31 Brooks Drive, Braintree, MA 02184-3804 or call our Customer Service Department at 1-800-SYMMONS. If writing to us, please include proof of purchase, the model number of the product with a brief description of the problem, your name, address and phone number. *Temptral series includes Allura®, Clide Braintree Brass®, Temptral, Temptral Deluxe and Temptral II shower and tub/shower systems. Symmons warrants to the original consumer purchaser that any TEMPTROL® series* or SYMMETRIX® product will be free of defects in material and

workmanship during normal domestic use for the life of your home. All other products and purchasers including industrial, commercial or business use are warranted for a period of 5 years from the date of purchase. At our option, we will either have you send the defective part or product prepaid to us for inspection, or we may elect to send you the replacement part or product without investigation. A replacement for any defective part will be supplied FREE OF CHARGE for installation by the purchaser. Defect or damage caused by the use of replacement parts other than Symmons Genuine Replacement Parts will void this warranty. This warranty excludes product damage due to installation error, product abuse, or product misuse whether performed by a contractor, service company or yourself. Symmons further warrants that any TEMPTROL or SYMMETRIX product will be leak free and drip free during normal domestic use for the life of your home. If the product should develop a leak or drip, Symmons will provide FREE OF CHARGE the parts necessary to return it to good working condition. Proof of purchase [original sales receipt] and a copy of the warranty registration card from the original consumer purchaser must accompany all warranty claims. This warranty is applicable only to Symmons TEMPTROL or SYMMETRIX products purchased after July 1, 1998 and shall be effective from the date of purchase as shown on the purchaser's receipt. Damage to the chrome and/or other decorative finishes on Symmons products may be a result of improper handling or abusive treatment. Finishes should only be cleaned with a soft, damp cloth or sponge. Use of polish, abrasive cleaners, solvents, or acid cleaners will damage the finish and void this warranty. There are no other express warranties on this product and ALL WARRANTIES OF MERCHANTABILITY AND OTHER IMPLIED WARRANTIES ARE LIMITED IN ACCORDANCE WITH APPLICABLE LAW. SYMMONS INDUSTRIES, INC., EXPRESSLY DISCLAIMS CONTINGENT LIABILITY AND CONSEQUENTIAL DAMAGE OF EVERY KIND. Since some states do not allow limitations on how long an implied warranty lasts or an exclusion or limitation of incidental or consequential damages the above limitation or exclusion may not be applicable. This warranty gives specific legal rights. Other rights may vary from state to state. To obtain warranty service, write to Symmons Industries, Inc., 31 Brooks Drive, Braintree, MA 02184-3804 or call our Customer Service Department at 1-800-SYMMONS. If writing to us, please include proof of purchase, the model number of the product with a brief description of the problem, your name, address and phone number. *Temptral series includes Allura®, Clide Braintree Brass®, Temptral, Temptral Deluxe and Temptral II shower and tub/shower systems.

Symmons Industries, Inc. ■ 31 Brooks Drive ■ Braintree, MA 02184
 (800) 796-6667, (781) 848-2250 ■ Fax (800) 961-9621, (781) 843-3849
 Website: www.symmons.com ■ Email: customerservice@symmons.com

©2014 Symmons Industries, Inc. Printed in U.S.A. ■ ZV-348 ■ 021414

