

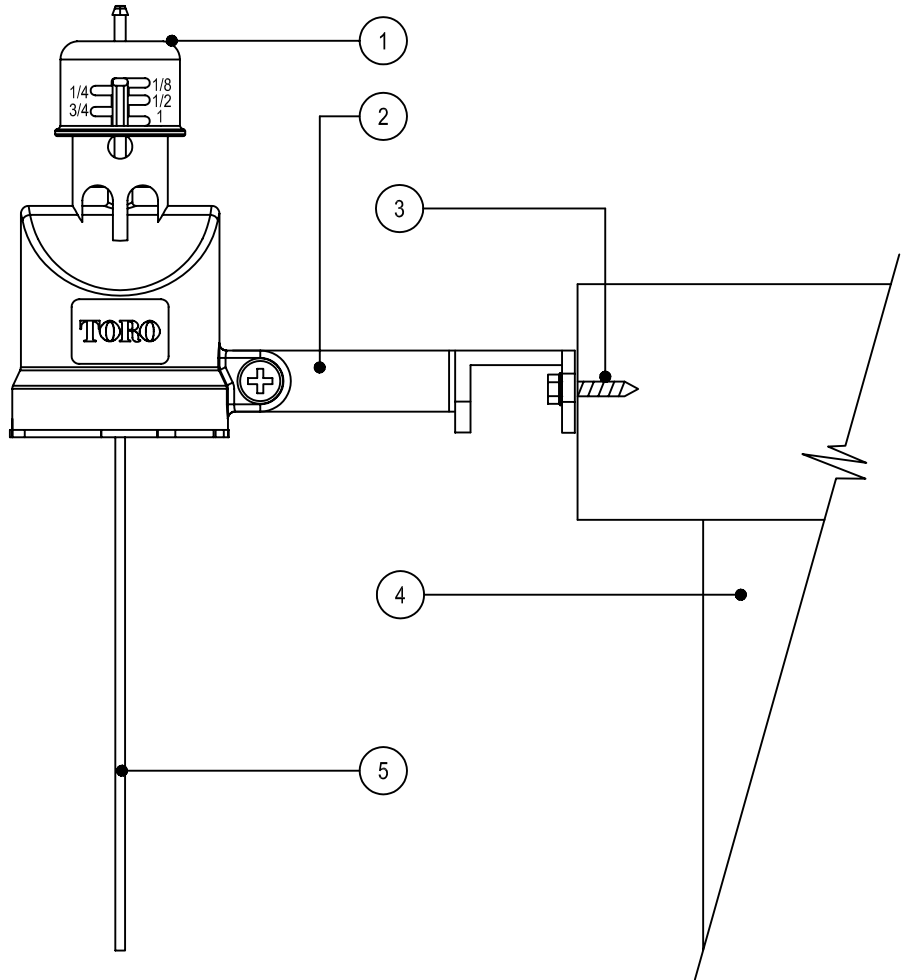

TORO-IRRIGATION DIVISION
 5825 JASMINE STREET
 RIVERSIDE, CA 92504
 TOLL FREE: 1-800-664-4740
 PHONE: (951) 785-3152
 FAX: (951) 359-1870
 www.toro.com

LEGEND

- 1. TORO WIRELESS RAIN SENSOR MODEL NO. TWRFS REFER TO PLAN FOR SENSOR LOCATION
- 2. ADJUSTABLE MOUNTING BRACKET
- 3. WOOD SCREW
- 4. WOOD FENCE
- 5. ANTENNA



MOUNT SENSOR VERTICALLY.
 AVOID PLACEMENT UNDER
 EVE OR TREE CANOPY.
 LOCATE WITHIN 300 FEET OF
 SENSOR RECEIVER AND
 CONTROLLER

SECTION/ELEVATION

NOT TO SCALE

NOTES:

- 1. INSTALLATION TO BE COMPLETED IN ACCORDANCE WITH MANUFACTURERS SPECIFICATIONS.
- 2. DO NOT SCALE DRAWINGS.
- 3. CONTRACTORS NOTE: FOR PRODUCT AND COMPANY INFORMATION VISIT www.CADdetails.com/info REFERENCE NUMBER 065-255b.

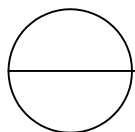

RAIN/FREEZE SENSOR - OTHER CONNECTIONS

WIRELESS (SURFACE MOUNT)