

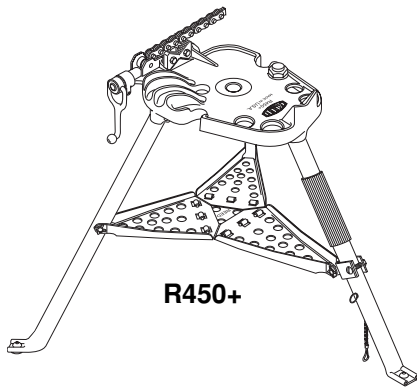

PIPE TOOLS & VISES
SINCE 1896

Chain Vise Tripod (R450+, R450C, R450P, R470+)

Replacement Parts



R450+

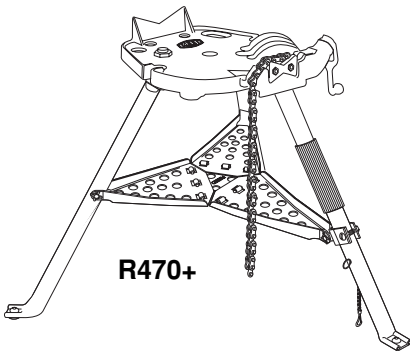

R470+

Capacity: 1/8" Through 6"

Patented

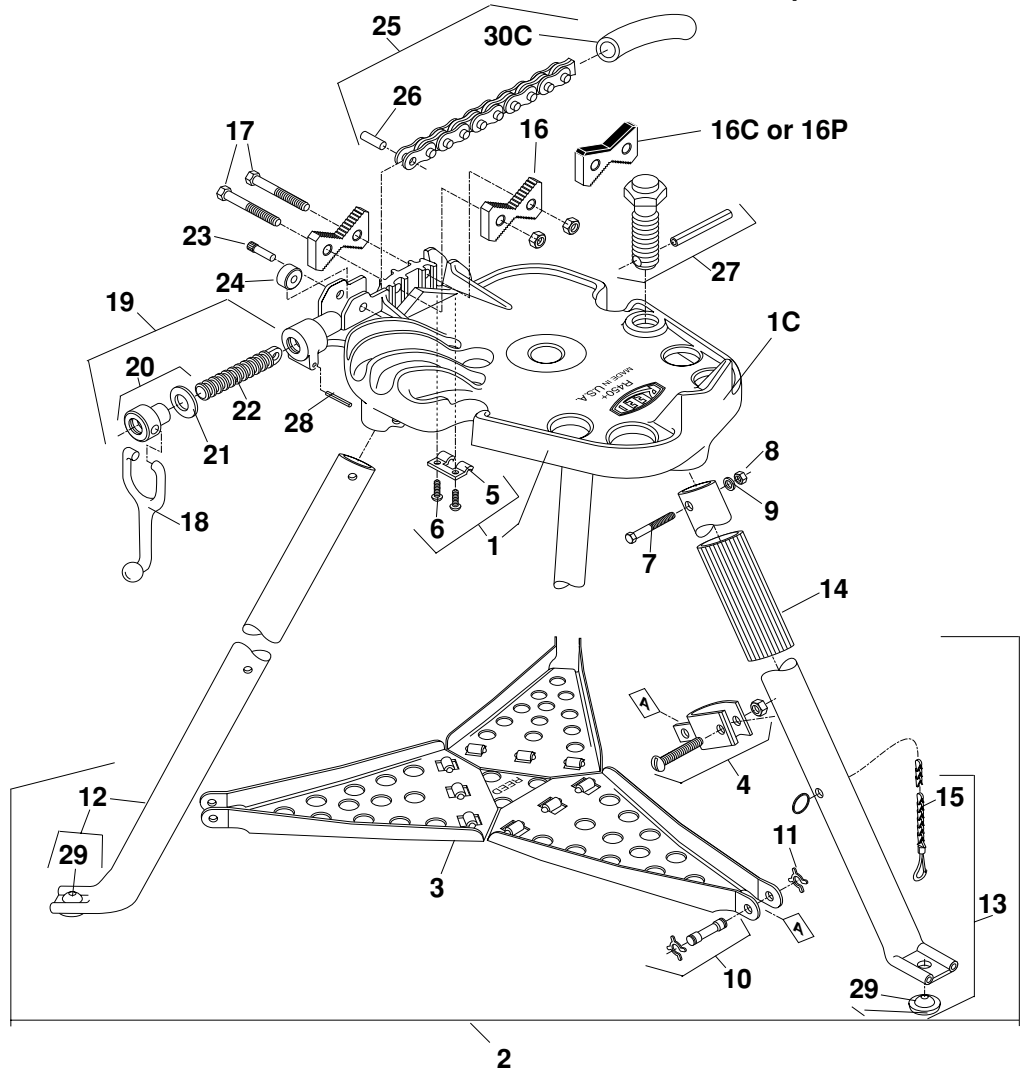

Parts List

Ref. No.	Description	REED (pack) Item Code	REED Item Code	Replaces Ridgid®	
				Cat No.	Old P/N
1A	R450+ Base with Wear Plate and Screws		99050	41170 / 72097*	—
1B	R470+ Base with Wear Plate and Screws		99403	—	—
1C	R450C Clean Room Base		99051	—	—
2	Leg & Tray Assembly		99052	40915	B-2007-X
3	Tool Tray		99004	41240	C-448
4	Tray Support Clamp w/screw & nut 99054		41235	D-488-X	—
5	Wear Plate		99022	40955	E-1339
6	Screw for wear plate (2)	5 Pk=99069	39002	40960	E-75-X
7	Leg Bolt (3)	5 Pk=99080	30187	46670	E-868
8	Nut (3)	5 Pk=99071	30032	44225	E-1094
9	Lock Washer (3)	5 Pk=99072	30033	40930	E-1095
10	Tray Pins (3) w/"X" Washers (6)		99053	41265	E-1375-X
11	"X" Washers (6)	6 Pk=99073	99010	41270	E-1377
12	Front Leg Assembly (2)		99057	41255	E-1385-X
13	Rear Leg Assembly		99058	41250	E-1389-X
14	Handle Grip		40183	—	—
15	Leg Chain Assembly		99055	40945	E-1444-X
16	Jaws (2)	Pair=99075	99021	—	—

Ref. No.	Description	REED (pack) Item Code	REED Item Code	Replaces Ridgid®	
				Cat No.	Old P/N
16C	R450C (2)	Pair=99076	99028	NI	NI
16P	R450P (2)	5 Pk=99077	99023	—	—
17	Jaw Screws & Nuts (2)	5 Pk=99059	99084	NI	NI
18	Handle		92007	NI	NI
19	Handle & Screw Assembly		99060	41050	E-3171-X
20	Handle with Nut & Washer		99061	NI	NI
21	Thrust Washer		99024	NI	NI
22	Chain Screw		99020	NI	NI
23	Roller Pin		92056	NI	NI
24	Roller		92010	40990	E-2488
25	Chain Assembly		99013	41075 / 72092*	—
26	Chain Screw Pin		92122	41040	E-2781
27	Jack Screw Assembly		99064	41230 / 72102*	—
28	Nut Locking Pin		93436	31650	E-4783
29	Grommet (3)	5 Pk=99079	40171	40940	F-532
30C	R450C Chain Cover for clean rooms		99030	—	—

NI - Not Interchangeable with Ridge Tool Co. parts. © Ridgid is a registered trademark of Ridge Tool Co.
*First number is for Ridgid 450, second number for Ridgid 460.

Reed Manufacturing Company
1425 West 8th St.
Erie, PA 16502 USA



Phone: 800-666-3691 or 814-452-3691
Fax: 800-456-1697 or 814-455-1697
www.reedmfgco.com

R450+ & R40+ Series Tripods

Operation & Instructions For Assembling Legs & Tray

R450+ Chain Vise Tripod
R450P Plastic Pipe Tripod
R450C Clean Room Tripod
R40+ Yoke Vise Tripod
R470+ Chain Vise Tripod

Patented

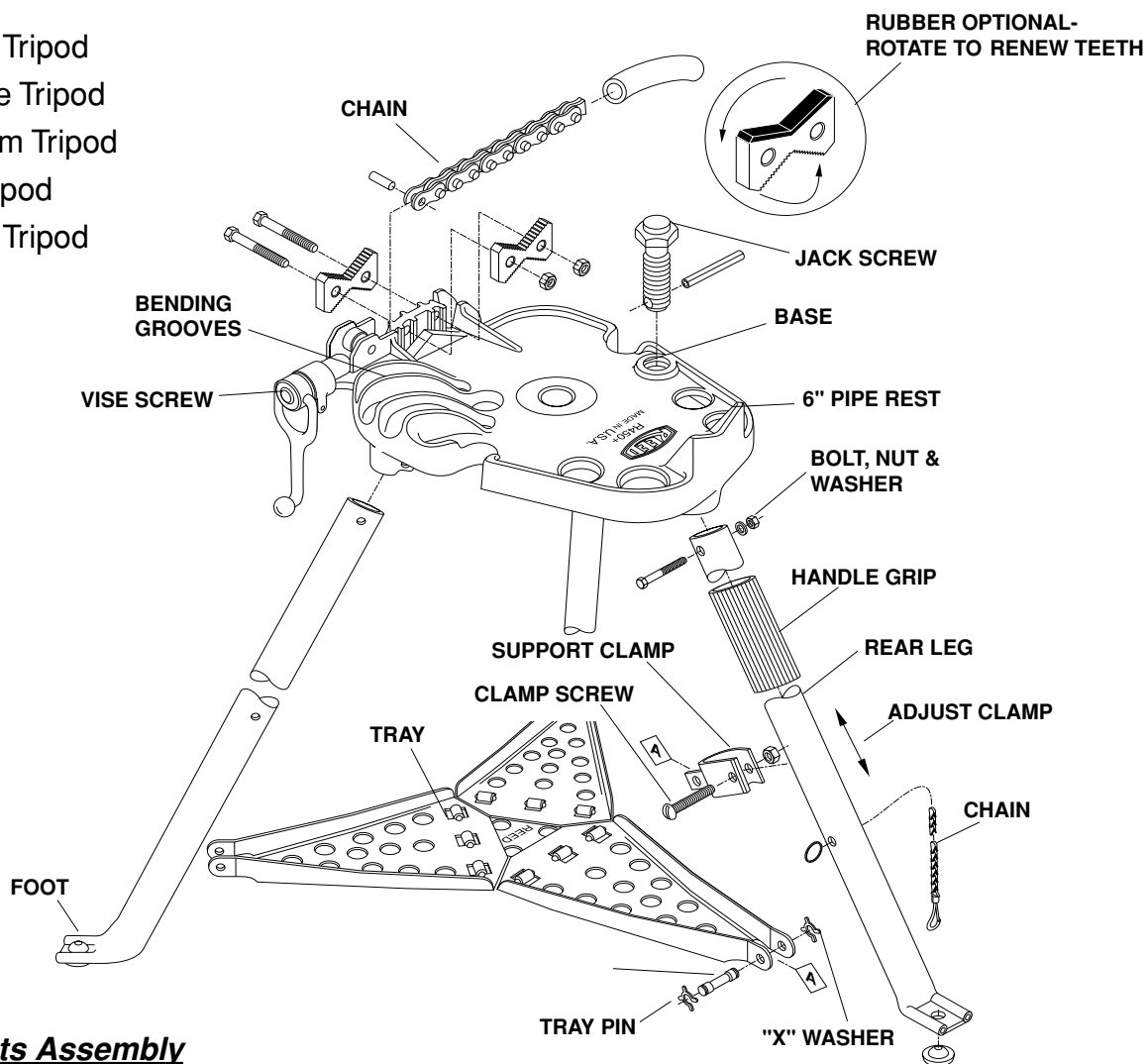

Replacement Parts Assembly

- 1) For easier assembly, place the base upside down on a flat surface.
- 2) Insert rear leg in base with foot pointing outward as shown. Secure to base with bolt, nut, and washer. Tray support is pre-set with a clamp collar for approximate position and is adjustable. (see "Tray Adjustment" note below).
- 3) Insert front legs so feet are pointing outward and secure to base with bolts, washers, and nuts.
- 4) To assemble tray, open tray so that side of flanges are facing bottom of base. Attach the rear leg first with tray pin then proceed to front legs.
- 5) Push "X" washers in pin grooves and pinch long ends together with pliers.
- 6) Stand trisand on legs. If you have a yoke vise tripod, assemble yoke to base. The hook on the yoke can either be on the right or left side depending on operator.

Operation and Maintenance

JAWS — To renew teeth—remove jaw screws and nuts, rotate jaws in either direction, replace jaw screws and nuts and tighten.

TRAY ADJUSTMENT— If folding tray does not snap into position and hold legs rigid when tripod is set up, loosen clamp screw in rear leg tray support and slide support clamp upward — tighten clamp screw securely.

JACK SCREW — Used with a length of 1" pipe as an adjustable ceiling brace to anchor tripod, but for large heavy pipe, fasten feet of tripod to floor securely.

BENDERS — Place pipe, conduit, or tubing into holes provided on base and pull down into grooves.

HANDLE GRIP — To install new handle grip over top of rear leg, insert compressed air hose nozzle under bottom edge and pull down while expanding with air flow.

LUBRICATION — Periodically lubricate the tray hinge, vise screw, jack screw, and chain with oil or spray silicone.