

Commercial Flue Damper Electronic Ignition Gas Water Heater (D-Series)



Photo is of
D-75T-125-3N

FEATURING:

THE BRADFORD WHITE
ICON HD[®]
COMMERCIAL CONTROL SYSTEM



3 or 5-Year Limited Tank Warranties / 1-Year Limited Warranty on Component Parts.

For more information on warranty, please visit www.bradfordwhite.com

For products installed in USA, Canada, and Puerto Rico. Some states do not allow limitations on warranties. See complete copy of the warranty included with the heater.

The Commercial Flue Damper Models feature:

- **ICON HD**[®]—Intelligent proven design combines temperature control, diagnostic codes, and system ignition functions into a single control board with a digital LCD display. Control panel cover tilts down for ease of wiring and service.
- **Operation Mode**—Two different digitally displayed operation modes have the capability of adjusting the temperature setting up to 180°F (82°C), and adjusting the degree setting (°F to °C, or °C to °F).
- **Service Mode**—Eight different digitally displayed service modes can be easily cycled through by pressing the select button.
 - Adjust the temperature setting up to 180°F (82°C)
 - Change the degree setting (°F to °C, or °C to °F)
 - Lock the maximum temperature setting that can be adjusted in operation mode
 - Display the average water temperature (for two sensor models) and see the upper and lower temperature sensor readings
 - Read the flame current of the pilot flame
 - Show diagnostic codes - 16 different numeric error codes; access an error code history of the last 10 codes
- **Electronic Ignition**—High voltage, low current electricity is sent to the pilot electrode initiating a spark to ignite the pilot gas. Saves pilot gas during standby periods; the pilot flame only operates when there's a call for heat.
- **Automatic Flue Damper**—Reduces stand-by loss, saving gas consumption and improving overall efficiency.
- **Factory Installed Hydrojet[®] Sediment Reduction System**—Cold water inlet sediment reducing device helps prevent sediment build up in the tank.
- **Vitraglas[®] Lining**—An exclusively engineered enamel formula that provides superior tank protection from the highly corrosive effects of hot water. This formula (Vitraglas[®]) is fused to the steel surface by firing at a temperature of over 1600°F (871°C).
- **Insulation System**—Non-CFC foam covers the sides and top of the tank, reducing heat loss. This results in less energy consumption, improved efficiencies, and jacket rigidity.
- **Water Connections**—1½" (38mm) NPT factory-installed true dielectric fittings extend water heater life and simplify water line connections.
- **Hand Hole Cleanout**—Allows inspection of tank interior and facilitates the removal of sediment deposits.
- **E.C.O.**—An automatic reset Energy Cut Out (E.C.O.) shuts off all gas in event of an overheat condition. This automatically resets when operation conditions are back to normal.
- **Protective Magnesium Anode Rods**—Provide added protection against corrosion for long-term, trouble-free service.
- **Sanitizing Capability**—Temperature setting up to 180°F (82°C).
- **ASME Code Available on all Models Above 200,000 BTU/Hr.**
- **NSF and Low NOx Construction Available.**
- **T&P Relief Valve**—Installed.
- **Low Restrictive Brass Drain Valve**—Durable tamper proof design.
- **Design certified by CSA International.**

Commercial Flue Damper Electronic Ignition Gas Water Heater

Electronic Ignition Models

NATURAL GAS AND LIQUID PROPANE GAS

Meet or exceed ASHRAE 90.1b (current standard) C.E.C. Listed

Model Number	Nominal Gal. Capacity		LP BTU/Hr. Input	GPH Recovery at Degree Rise*			A Floor to Vent Conn. in.	B Jacket Dia. in.	C Vent Size in.	D Floor to T&P Conn. in.	E Floor to Gas Conn. in.	F Floor to Top of Heater in.	G Floor to Top Water Conn. in.	K Floor to Water Conn. Cold in.	L Floor to Water Conn. Hot in.	Depth in.	C/L of Water Conn. in.	Water Conn. NPT in.	Gas Conn. Size in.	Approx. Shipping Weight (lbs.)		
	U.S. Gal.	Imp. Gal.		40°F	100°F	140°F														Std.	ASME	
D-38T-155-3N+	38	31	155,000	155,000	376	150	107	5 1/16	28 1/4	6	34 3/8	5 1/16	43 9/16	-	19 13/16	35 3/16	32 1/2	-	1 1/2 (F)	3/4	438	-
D-65T-370-3N(A)	65	54	370,000	370,000	897	359	256	7 1/8	28 1/4	8	54	6 1/4	63 7/8	-	28 3/4	54	33 3/8	-	1 1/2 (F)	1 1/8 (LP)	665	720
D-65T-399-3N(A)**	65	54	399,999	-	970	388	277	7 1/8	28 1/4	8	54	6 1/4	63 7/8	-	28 3/4	54	33 3/8	-	1 1/2 (F)	1 (N)	665	720
D-75T-125-3N	75	62	125,000	125,000	303	121	86	76	28 1/4	5	55 13/16	8 11/16	65 1/16	70	25 7/16	66 1/4	32 1/2	14 1/2	1 1/2 (T&F)	3/4	520	-
D-75T-160-3N	75	62	160,000	155,000	389	155	111	76	28 1/4	6	55 13/16	8 11/16	65 1/16	70	25 7/16	66 1/4	32 3/8	14 1/2	1 1/2 (T&F)	3/4	520	-
D-75T-300-3N(A)	75	62	300,000	300,000	727	291	208	75 9/16	28 1/4	7	52 29/32	8 11/16	65 15/16	-	28 7/8	54 3/16	33 3/8	-	1 1/2 (F)	3/4	590	645
D-80T-180-3N	80	67	180,000	180,000	436	175	124	72 3/4	28 1/4	6	55 5/8	5	64 3/4	70	20	56 1/2	32 1/2	19	1 1/2 (T&F)	3/4	540	-
D-80T-199-3N	80	67	199,999	199,999	485	194	139	72 3/4	28 1/4	6	55 5/8	5	64 3/4	70	20	56 1/2	32 1/2	19	1 1/2 (T&F)	3/4	540	-
D-80T-250-3N(A)	80	67	250,000	235,000	606	242	173	72 3/4	28 1/4	6	55 5/8	5	64 3/4	70	20	56 1/2	32 1/2	19	1 1/2 (T&F)	3/4	540	590
D-80T-425-3N(A)	80	67	425,000	425,000	1030	412	294	83 13/16	28 1/4	10	65 5/8	6 1/4	79 5/16	-	23 1/2	66 5/8	34 1/2	-	1 1/2 (F)	1 1/8 (LP)	750	800
D-80T-505-3N(A)	80	67	505,000	505,000	1178	489	337	83 13/16	28 1/4	10	65 5/8	6 1/4	79 5/16	-	23 1/2	66 5/8	34 1/2	-	1 1/2 (F)	1 1/8 (LP)	750	800
D-100L-199-3N	100	83	199,999	199,999	485	194	139	73 1/4	30 1/4	6	59 9/16	8 11/16	65 3/16	70 1/2	30 3/8	56 9/16	34 1/2	23	1 1/2 (T&F)	3/4	725	-
D-100S-199-3N	100	83	199,999	199,999	485	194	139	75 11/16	28 1/4	6	61 3/8	8 11/16	68 7/8	70	21 9/16	61 1/4	32 1/2	21	1 1/2 (T&F)	3/4	667	-
D-100T-199-3N	98	82	199,999	199,999	485	194	139	83 13/16	28 1/4	6	66 5/8	8 11/16	75 7/16	81 1/2	23 1/2	66 5/8	32 1/2	19	1 1/2 (T&F)	3/4	610	-
D-100L-250-3N(A)	100	83	250,000	250,000	606	242	173	73 1/4	30 1/4	6	56 9/16	8 11/16	65 3/16	70 1/2	30 3/8	56 9/16	34 1/2	23	1 1/2 (T&F)	3/4	725	765
D-100S-250-3N(A)	100	83	250,000	250,000	606	242	173	75 11/16	28 1/4	6	61 3/8	8 11/16	68 7/8	70	21 9/16	61 1/4	32 1/2	21	1 1/2 (T&F)	3/4	667	702
D-100T-250-3N(A)	98	82	250,000	235,000	606	242	173	83 13/16	28 1/4	6	66 5/8	8 11/16	75 7/16	81 1/2	23 1/2	66 5/8	32 1/2	19	1 1/2 (T&F)	3/4	610	690
D-100L-270-3N(A)**	100	83	270,000	-	655	262	187	73 1/4	30 1/4	6	56 9/16	8 11/16	65 3/16	70	30 3/8	56 9/16	34 1/2	23	1 1/2 (T&F)	3/4	725	765
D-100L-300-3N(A)	100	83	300,000	300,000	727	291	208	73 1/4	30 1/4	7	56 9/16	8 11/16	65 3/16	70	30 3/8	56 9/16	34 1/2	23	1 1/2 (T&F)	3/4	725	765

Model Number	Nominal Liter Capacity		LP kW Input	LPH Recovery at Degree Rise*			A Floor to Vent Conn. mm.	B Jacket Dia. mm.	C Vent Size mm.	D Floor to T&P Conn. mm.	E Floor to Gas Conn. mm.	F Floor to Top of Heater mm.	G Floor to Top Water Conn. mm.	K Floor to Water Conn. Cold mm.	L Floor to Water Conn. Hot mm.	Depth mm.	C/L of Water Conn. mm.	Water Conn. NPT mm.	Gas Conn. Size mm.	Approx. Shipping Weight (kg.)	
	22°C	56°C		78°C	Std.	ASME															
D-38T-155-3N+	144	45.4	45.4	1391	556	397	1310	718	152	873	129	1106	-	503	894	826	-	38 (F)	19	199	-
D-65T-370-3N(A)	246	108.4	108.4	3395	1359	969	1819	718	203	1370	159	1622	-	731	1370	845	-	38 (F)	25 (LP)	302	327
D-65T-399-3N(A)**	246	117.2	-	3671	1469	1048	1819	718	203	1370	159	1622	-	731	1370	845	-	38 (F)	25	302	327
D-75T-125-3N	284	36.6	36.6	1147	458	326	1930	718	127	1418	221	1653	1778	646	1683	826	368	38 (T&F)	19	236	-
D-75T-160-3N	284	46.8	45.4	1431	572	409	1930	718	152	1418	221	1653	1778	646	1683	822	368	38 (T&F)	19	236	-
D-75T-300-3N(A)	284	87.9	87.9	2752	1101	787	1919	718	178	1339	221	1675	-	733	1376	845	-	38 (F)	19	268	393
D-80T-180-3N	303	52.7	52.7	1650	662	469	1848	718	152	1413	129	1645	1778	502	1435	826	483	38 (T&F)	19	245	-
D-80T-199-3N	303	58.6	58.6	1836	734	526	1848	718	152	1413	129	1645	1778	502	1435	826	483	38 (T&F)	19	245	-
D-80T-250-3N(A)	303	73.2	68.9	2294	916	655	1848	718	152	1413	129	1645	1778	502	1435	826	483	38 (T&F)	19	245	268
D-80T-425-3N(A)	303	124.5	124.5	3899	1559	1113	2129	718	254	1684	159	2015	-	598	1684	876	-	38 (F)	25 (LP)	340	363
D-80T-505-3N(A)	303	148.0	148.0	4459	1783	1276	2129	718	254	1684	159	2015	-	598	1684	876	-	38 (F)	25 (LP)	340	363
D-100L-199-3N	379	58.6	58.6	1836	734	526	1860	768	152	1437	221	1656	1791	779	1437	876	584	38 (T&F)	19	329	-
D-100S-199-3N	379	58.6	58.6	1836	734	526	1922	718	152	1554	221	1749	1778	548	1554	826	533	38 (T&F)	19	302	-
D-100T-199-3N	371	58.6	58.6	1836	734	526	2129	718	152	1684	221	1916	2070	597	1684	826	483	38 (T&F)	19	277	-
D-100L-250-3N(A)	379	73.2	73.2	2294	916	655	1860	768	152	1437	221	1656	1791	779	1437	876	584	38 (F)	19	329	347
D-100S-250-3N(A)	379	73.2	73.2	2294	916	655	1922	718	152	1554	221	1749	1778	548	1554	826	533	38 (T&F)	19	302	318
D-100T-250-3N(A)	371	73.2	68.9	2294	916	655	2129	718	152	1684	221	1916	2070	597	1684	826	483	38 (T&F)	19	277	313
D-100L-270-3N(A)**	379	79.0	-	2479	992	708	1860	768	152	1437	221	1656	1778	779	1437	876	584	38 (F)	19	329	347
D-100L-300-3N(A)	379	87.9	87.9	2752	1101	787	1860	768	178	1437	221	1656	1778	779	1437	876	584	38 (F)	19	329	347

(A) = ASME Code Available

(F) = Front Water Connection

(T) = Top Water Connection

** = Available in Natural Gas Only

+ = Fiberglass Insulation

For Propane (LP) Gas models change suffix "N" to "X".

220V/50Hz Available - Consult factory.

* Recoveries are based on Natural Gas Input and 80% Thermal Efficiency.

Low NOx models are not available for inputs over 399,999 BTU/Hr.

For Low NOx compliance, place an "E" following the BTU input identifier of the model number.

Example: D-75T-125E-3N

Amperage Draw = .5 for damper models/less than 4 for induced draft models.

Power Vent Kits—available for inputs from 125,000 to 505,000 BTU/Hr.

For 5 year models change suffix from "3" to "5".

Commercial Flue Damper Electronic Ignition Gas Water Heater

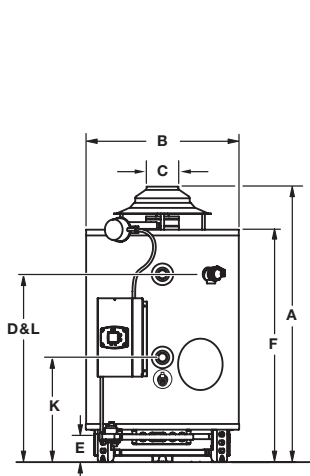

Model D-38T-155

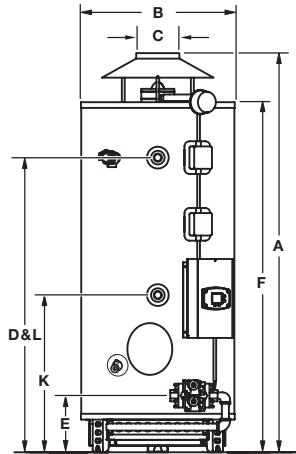

Model D-65T-(370,399)

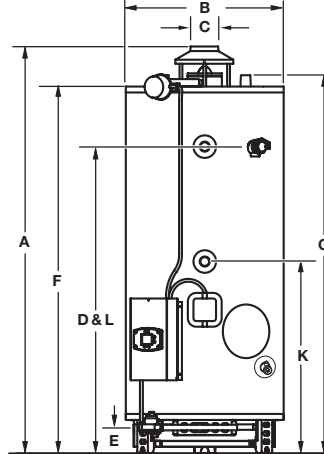

Model D-75T-(125,160)

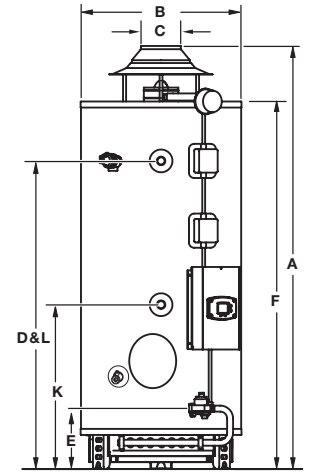

Model D-75T-300

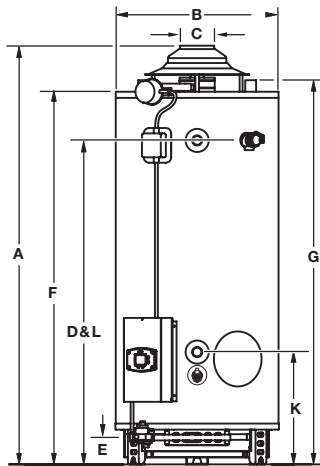

Model D-80T-(180,199,250)

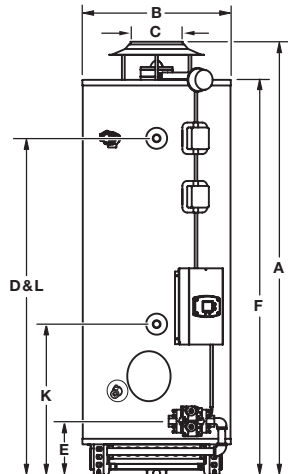

Model D-80T-(425,505)

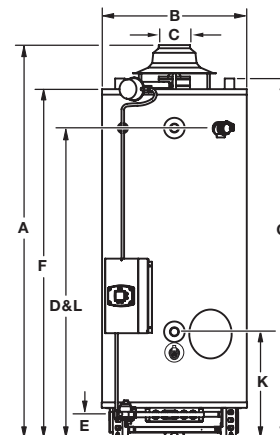

Model D-100S-(199,250)

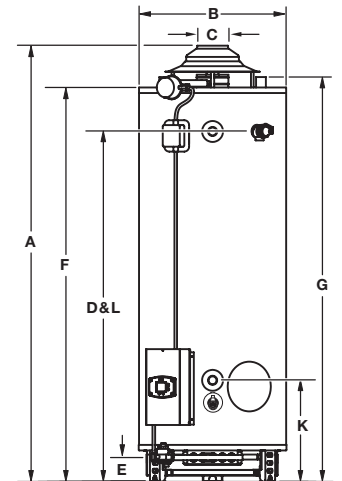

Model D-100T-(199,250)

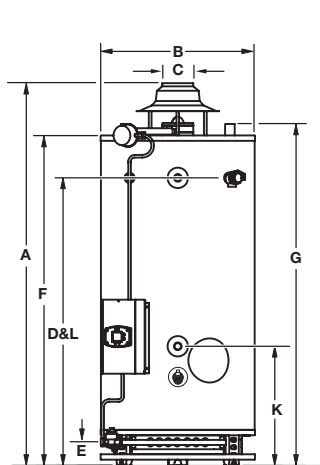

Model D-100L-(199,250,270,300)

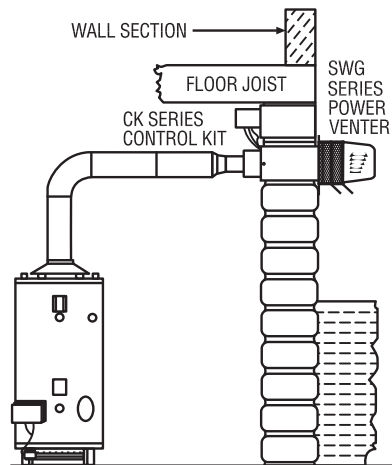

TYPICAL APPLICATIONS

Optional Equipment and Features:

Alarm Module—

Provides indication (contacts are closed) when an alarm is present via normally open contacts (rated for up to 24 VAC).

Kit Number – 265-51961-00

Power Vent Kits—

Available for inputs from 125,000 to 505,000 BTU/Hr.

BTU Input Range

BTU Input Range	Kit Number
125,000 to 290,000 BTU/Hr.:	239-81764-00
300,000 to 399,999 BTU/Hr.:	239-81766-00
425,000 to 505,000 BTU/Hr.:	239-82148-00

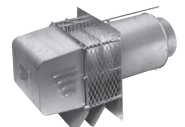

Commercial Flue Damper Electronic Ignition Gas Water Heater

Sample Specification

The water heater shall be a Bradford White model with a rated storage capacity of not less than _____ gallons (_____ liters), a minimum gas input of _____ BTU/Hr. (_____ kW), a minimum recovery of _____ GPH (_____ LPH). The tank shall be Vitraglas® lined and have a bolted hand hole cleanout. A digital LCD display shall be integrated into the front control box, and the control shall be an adjustable electronic thermostat to any temperature up to 180°F (85°C) must have an automatic re-set Energy Cut-off (E.C.O), which shuts off all gas in an event of a overheat condition. The tank shall have _____ magnesium anode rods installed in separate tank head couplings. The heater shall have Non-CFC foam insulation, electronic ignition, and come equipped with an ASME rated T&P relief valve, a cold water inlet Hydrojet® Sediment Reduction System, and a automatic flue damper (115V AC required). It shall be design certified by CSA International for 180°F (82°C) application, either with or without a separate storage tank, and comply with state and local codes and ordinances.

General

All gas water heaters are certified at 300 PSI test pressure (2068 kPa) and 150 PSI working pressure (1034 kPa). All models are design certified by CSA International (formerly AGA/CGA), ANSI standard Z21.10.3, for up to 180°F (82°C) application as an Automatic Storage Heater, and an Automatic Circulating Tank Heater. As an Automatic Storage Heater, all models are complete, self-contained water heating systems. It needs no separate storage tank, pump, wiring or elaborate piping network. When equipped with a mixing valve, it will supply 180°F (82°C) sanitizing and lower temperature general purpose hot water simultaneously. These models can be used either as a single unit or in multiples connected in series or parallel (recommended).

Dimensions and specifications subject to change without notice in accordance with our policy of continuous product improvement.

— BRADFORD WHITE IS —

**AMERICAN
STRONG**

Sales: 800-523-2931 ■ Fax 215-641-1612
24/7 Technical Support: 800-334-3393 ■ Email techserv@bradfordwhite.com

Built to be the Best