



# Principles of Pressure Regulation

Zurn Wilkins Pressure Reducing Valves



1.855.ONE.ZURN | ZURN.COM



# Benefits of Pressure Reduction

Pressure Reducing Valves (PRVs) are used to lower the municipal water supply pressure feeding commercial buildings and homes. Pressure reducing valves are required by code when the street pressure is higher than 80 psi. In addition to meeting code, there are numerous benefits to installing a PRV in plumbing or irrigation system.



## Water Conservation

Adjusting the pressure from 100 psi to 50 psi reduces water consumption by 33% in the average household, resulting in reduced resource and sewage treatment, lowering water and sewer bills.



## Energy Conservation

Less water is pumped through the distribution system, resulting in lower energy and heating costs for the water purveyor and sewage treatment facility.



## Extend System Life

PRVs help extend the life of pipes, faucets, and appliances by reducing wear on system components caused by excessive pressure. Long-term pressure may lead to breakage, causing flooding and property damage.



## Irrigation Systems

Typical irrigation systems require pressure below 70 psi in order to adequately water landscapes while reducing water waste. PRVs maintain this pressure while preventing premature solenoid valve and sprinkler head failure, water hammer, and nozzle fogging.

# Zurn Wilkins PRVs

With over 100 years of trusted performance, Zurn Wilkins PRVs offer durability and proven reliability. Installing a Zurn Wilkins PRV on the average home will result in annual savings of between 30,000 and 40,000 gallons of water when reducing pressure from 100 psi to 50 psi.

## How PRVs Operate

Zurn Wilkins direct-acting Pressure Reducing Valves are normally open and are biased to the open position by a pre-loaded spring (1).

The valve will remain in the open position until downstream pressure forces the plunger (2) onto the seat (3), closing the valve. The valve is closed by reduced pressure water pushing on the wetted side of the diaphragm (4), countering the force of the spring (1). The amount of reduced pressure is directly proportional to the pre-loaded spring (1).

When the valve is pressurized, it remains closed until downstream demand is placed on the system. When demand occurs, such as turning on a faucet, the outlet pressure drops and decreases the force on the wetted side of the diaphragm (4), allowing the spring (1) to bias the valve open to satisfy demand.

The valve will continue to modulate in the open position until the demand placed on the system ceases.

When demand ceases, the valve will close. Pressure Reducing Valves are capable of holding the static downstream pressure within very narrow limits because the operating intelligence for PRVs is independent of inlet pressure, regardless of inlet pressure fluctuations.

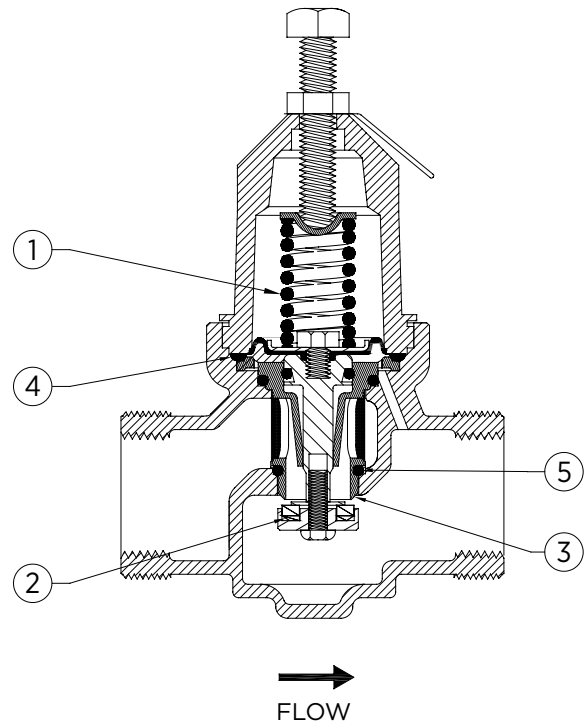

## Integral By-Pass

The pressure downstream of a PRV can build from thermal expansion or the use of pumps. When downstream pressure builds and exceeds inlet pressure, an integral by-pass bleeds off excess pressure by allowing water to flow upstream through the by-pass, limiting pressure build in a system to that of the inlet pressure.

With an integral by-pass, pressure in a system will never exceed that of the inlet pressure if there is no backflow prevention device installed.

Excess downstream pressure can cause a Temperature and Pressure Relief Valve (T&P Valve) installed on the hot water heater to open when system pressure exceeds the T&P Valve set point (typically 150 psi). T&P Valves are safety devices designed to operate a limited number of times in emergency situations only. An integral by-pass will keep pressure from rising to the T&P opening point if inlet pressure is less than 150 psi.

All Zurn Wilkins PRVs have integral by-passes that operate by using an o-ring in a conic o-ring gland (5).

Under normal conditions, where water pressure coming into the PRV is greater than the downstream pressure, the o-ring is pushed into the narrow section of the gland by incoming pressure and seals tight.

In the event that the pressure on the downstream side of the regulator becomes equal to the incoming pressure, the o-ring will slide to the wide section of the gland to un-seal, opening the by-pass.

If a backflow preventer is present, or if inlet pressure is excessive, a pressure relief valve or thermal expansion tank (Zurn Wilkins XT series) should be installed downstream of the PRV should be thermal expansion.

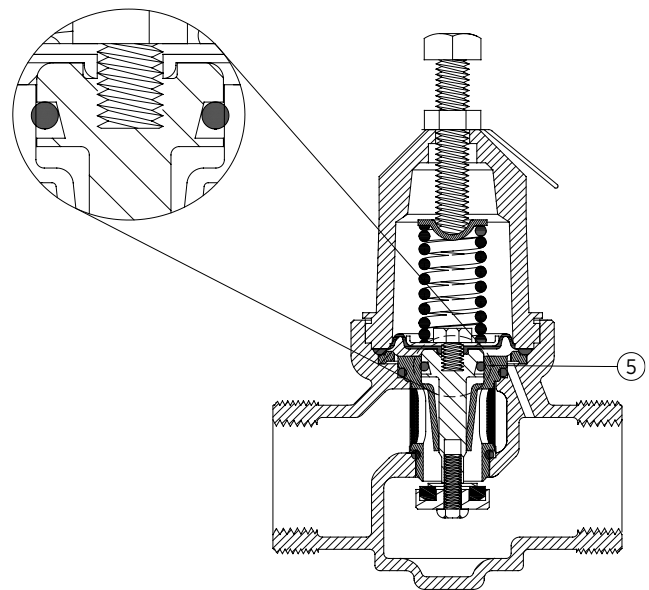

NR3XL with Integral By-Pass

# Zurn Wilkins PRV Features

**Bronze and composite construction** reduces electrolytic corrosion. Electrolytic corrosion occurs when two dissimilar metals are joined and react to each other. XL models are constructed of lead-free bronze and contain a weighted average lead content less than 0.25% for wetted surfaces.

**Threaded bell** provides easy access to the spring, diaphragm, screen or plunger for service and maintenance. Eliminates screws that can corrode.

**Hex on bell** provides greater repair access without removing screws and without special tools.

**Stainless steel screen** is durable and corrosion resistant, eliminating debris that causes fouling.

**Nylon reinforced Buna-N diaphragm** provides superior strength.

**Stainless steel or composite seat** is durable and corrosion resistant, reducing potential for wire draw.

**Patented o-ring by-pass** prevents a pressure build up from thermal expansion.

**Union connections available** on all Zurn Wilkins PRVs up to 2", allowing greater installation versatility. Double unions, PEX, copper sweat, NPT, CPVC, and solderless connections available.

**Full Approval Set** including ASSE, IAPMO, CSA, and more.

**Every valve is hydrostatically tested** at the factory under rigorous conditions.

**Z-Bite™ and Z-Press™ Solderless Connections** available in union tailpiece connections and integral fittings for easy installation.

**Orientation** - can be installed in any position. Common approved installation positions include single PRV, sealed cage/pit installation, PRVs in series, and PRVs in parallel.

## Typical Installations

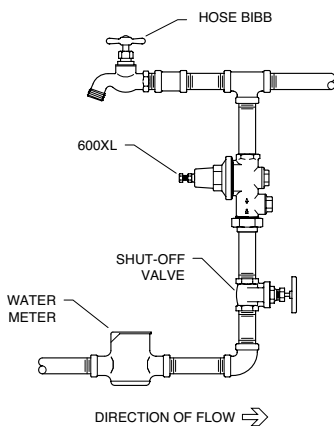

### Single PRV

The normal installation on residential and small commercial applications is the single PRV. This installation requires that the PRV handle all demand flows from zero to full capacity.

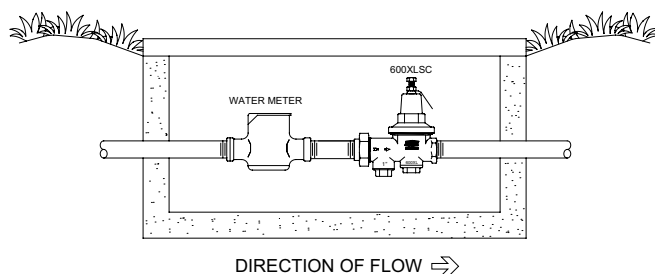

### Pit Installation/Sealed Cage

Used in below grade applications to prevent water intrusion into the bell. Specify the Sealed Cage (SC) option for corrosive environments.

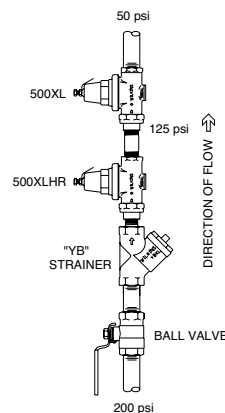

### Series Installation

Two valves are used when the pressure reduction ratio is equal to or greater than 4:1 (ex. 200 psi to 50 psi).

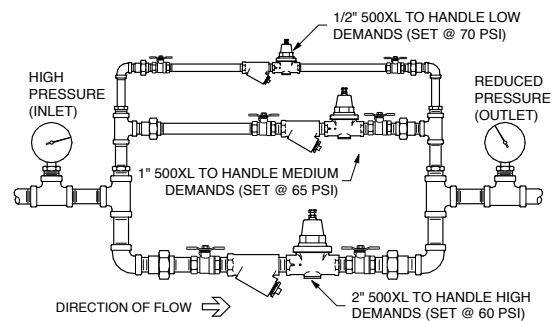

### Parallel Installations

In many instances a battery installation is preferable to the use of a single valve, as it provides closer regulation over a wide demand variation. Typically used in applications where the flow rate varies from very low to very high, and when a single PRV does not provide the capacity needed.

After installation the smallest PRV is set to the highest pressure, with each successively larger PRV set 3-5 psi lower.

# Common PRV Applications

PRV	RESIDENTIAL	LIGHT COMMERCIAL	COMMERCIAL	INDUSTRIAL
NR3XL Series	✓			
70XL Series	✓	✓		
600XL Series	✓	✓	✓	
500XL Series			✓	
80 Series	✓	✓	✓	✓
90 Series	✓	✓	✓	✓

## NR3XL

### APPLICATIONS

With its corrosion resistant plastic cartridge and ease of repair, the NR3XL is the perfect Pressure Reducing Valve for residential applications.



### FEATURES

- 1/2" - 2"
- Pressure rated 400 psi (1/2" - 1-1/4"), 300 psi (1-1/2", 2")
- Spring range 15 to 75 psi (1/2" - 1-1/4"), 25 to 75 psi (1-1/2", 2")
- Factory set at 50 psi
- 140°F max
- Replaceable acetal cartridge with integral stainless steel strainer
- Short lay length makes for easy retrofit

### APPROVALS AND APPLICABLE SPECIFICATIONS

ASSE® Listed 1003, IAPMO® Listed, CSA® Certified  
 Certified to NSF/ANSI 61 and 372

## 70XL

### APPLICATIONS

The 70XL has been providing residential and commercial customers with ruggedness and ease of repair for over 40 years.



### FEATURES

- 3/4" - 1"
- 300 psi max
- Spring range 25 to 75 psi; factory set at 50 psi
- 140°F max
- All bronze body and bell housing provides durability and long life
- Corrosion-resistant, replaceable cartridge with integral stainless steel strainer

### APPROVALS AND APPLICABLE SPECIFICATIONS

ASSE® Listed 1003, IAPMO® Listed, CSA® Certified, City of Los Angeles  
 Certified to NSF/ANSI 61 and 372

## 500XL

### APPLICATIONS

High flow rates and low fall-off are the hallmark of the 500XL series. Perfect for your commercial or industrial pressure reduction applications.



### FEATURES

- 1/2" - 3"
- 300 psi max
- Spring range 25 to 75 psi
- 140°F max
- All bronze body and bell housing provides durability and long life
- All internal parts corrosion-resistant
- 500XLFC (with flanged connections) available in 2" - 3"
- 500XLYSBR (with Model SXL wye type strainer) available in 1/2" - 3"

### APPROVALS AND APPLICABLE SPECIFICATIONS

ASSE® Listed 1003 (1/2"-2-1/2"), IAPMO® Listed (1/2"-2"), CSA® Certified (1/2"-2"), City of Los Angeles (1/2"-3")  
 Certified to NSF/ANSI 61 and 372

## 600XL

### APPLICATIONS

Sandy, debris laden water systems result in frequent PRV strainer cleanings. The 600XL, with its separate strainer cap, allows this task to be completed rapidly, and is utilized in residential and commercial applications.



### FEATURES

- 1/2" - 2"
- Spring range 25 to 75 psi
- 300 psi max
- 140°F max
- All bronze body and bell housing provides durability and long life
- Integral stainless steel strainer with separate access cover

### APPROVALS AND APPLICABLE SPECIFICATIONS

ASSE® Listed 1003, IAPMO® Listed, CSA® Certified, City of Los Angeles  
 Certified to NSF/ANSI 61 and 372

## 80CI

### APPLICATIONS

Residential boilers typically operate at very low pressures. The 80CI is an exceptional choice for lowering pressure to a boiler system.



### FEATURES

- 1/2"
- 100 psi max
- 210°F max
- Reduced pressure range 10 psi to 25 psi
- Factory preset 15 psi
- Standard with 20 mesh strainer screen
- Cast iron construction

## 90

### APPLICATIONS

Precise pressure control in drip irrigation or other irrigation applications is the function of the 90.



### FEATURES

- 3/4", 1"
- 300 psi max
- Spring range 0 to 50 psi; factory set at 30 psi
- 140°F max
- All bronze body and bell housing provides durability and long life
- Integral stainless steel strainer
- Non-potable applications only

# Valve Selection and Sizing

The selection of the correct type of PRV depends entirely on the accuracy of the pressure regulation required.

## The Best Way

The recommended valve selection process requires that you capacity-size a valve based on the known performance data of the system.

The following system performance criteria must be considered:

- Flow required for the application in Gallons per Minute (gpm)
- Delivery pressure of the water in Pounds per Square Inch (psi)
- The maximum allowable difference between downstream flowing pressure and static pressure or the Fall-off (static set pressure minus flowing pressure)

## Valve Sizing Issues

Over-sizing a valve can create serious system problems, such as excessive wear, vibration, wire draw, and noise. Some installers/designers may think they are doing their client a favor by over-sizing, but this is simply not true.

Under sizing causes very high flowing velocity, which will cause noise, wear of the internal components, excessive fall-off, and rapid failure of the valve.

Capacity rating of a PRV does not take all the system requirements into consideration, and should be avoided.

Line sizing, just like capacity rating, does not take into consideration all system requirements and should be avoided. Size-to-size selection uses a valve with the same connection size as the pipeline in which it is to be installed.

## Performance Curves

Flow charts for all valves are displayed on the basis of rate of flow against the reduced pressure fall-off, where pressure fall-off is defined as the difference between the downstream set static pressure and the flowing water pressure.

The zero (0) on the fall-off column represents the reduced pressure setting of the regulator when there is no flow, commonly called the reduced lock-up pressure. It can be any setting within the adjustment range of the PRV. The figures above the zero (0) show the fall-off or pressure change that is necessary to produce the flows indicated by the curves of various size valves. It should be noted that the curves terminate with a maximum fall-off of 20 psi. Exceeding a 20 psi fall-off is not recommended due to high velocity, noise, and rapid wear of the PRV. When a fall-off greater than 20 psi occurs, the next larger PRV size is needed.

All Zurn Wilkins PRV flow curves are based upon a 50 psi differential across the valve. In cases where a differential less than 50 psi occurs, deduct 20% from the capacity shown.

### Example: Select proper size valve

**Given:**

**Inlet pressure:** 110 psi

**Reduced no-flow pressure:** 50 psi

**Demand:** 20 gallons per minute

**Allowable fall-off:** 12 to 17 psi

**Procedure:** On the chart, locate 20 gallons per minute on the bottom lie and move up until it intersects the last valve size curve that is within the given allowable fall-off parameters of 12 to 17 psi. In this case, the 3/4" size provides design capacity at a fall-off of 14 psi, well below the allowable fall-off requirement.

### Example: Determine the flow capacity

**Given:** 1-1/4" Model 600XL Valve

**Procedure:** On the chart, find the intersection of the 1-1/4" size curve and the 20 psi fall-off line. Moving down from the intersection to the flow rate line, the capacity of 53 gpm is indicated

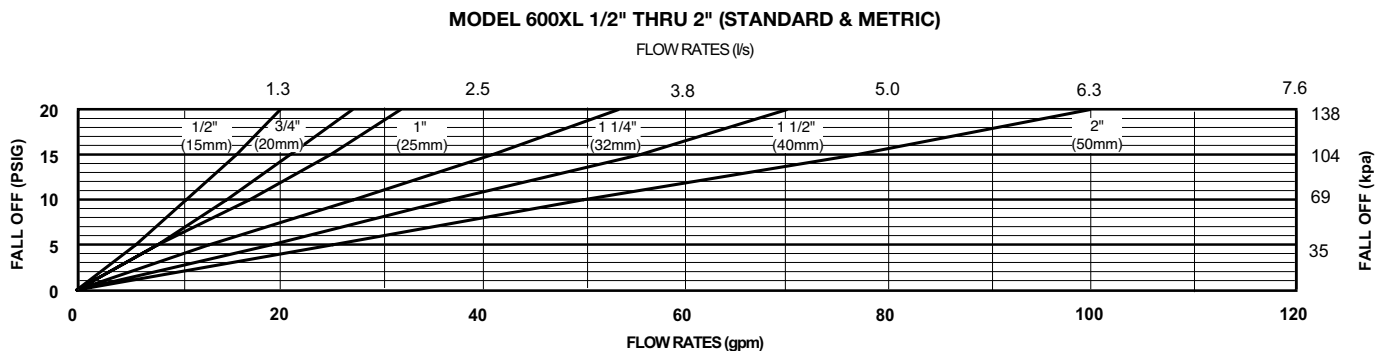

# Troubleshooting

Pipe lines in a water supply system must allow sufficient carrying capacity to maintain adequate pressure at the most remote or highest fixture. Under the maximum probable fixture use, minimum adequate pressure is generally 8 to 15 lbs. but may be more, depending on the equipment being supplied. Relatively high service pressures can create high water velocities in pipe lines, allowing smaller pipes to satisfy fixture use. However, high velocity tends to cause whistling and humming. Reduction of pressure by the use of a pressure reducing valve may reduce pipe line capacities below that which is adequate for maximum probable use. When high service pressures are in effect, the application of a pressure reducing valve will be successful only when the installed pipe line is of adequate size. When actual water demands are unknown, the valve size should be no smaller than the existing pipe size.

**Problem 1:** Pressure creeps or builds up in system above the setting of pressure reducing valve.

#### Possible Cause or Causes

- A Thermal expansion of water as it is being heated.
- B Foreign matter on seating face of seal ring.
- C Cut, worn or chipped seal ring.
- D Cut or worn stem o-ring or worn o-ring groove.

#### Solution

- A This is a natural consequence. It may happen each time that the heater runs. A pressure relief valve or expansion tank must be installed. This will not prevent pressure rise but should limit it to a safe level.
- B Flush the reducing valve by opening one or two fixture outlets wide. If this does not correct the problem, remove seal ring for cleaning.
- C Replace with new seal ring. Temporary repairs may be made by turning the seal ring over.
- D Replace with new stem o-ring and/or cartridge.

---

**Problem 2:** Pressure and fixture flow is unsteady.

#### Possible Cause or Causes

- A Low water supply pressure in mains caused possibly by high area demand during certain periods of the day.
- B Heavy periodic demands by appliances in the house.

#### Solution

- A This is a water department problem. It is due to the mains being inadequate for the demands made on them.
- B House service lines may at times be inadequate for the load. Size of some pipelines may need to be increased. Pressure setting of reducing valve may be too low.
- C Try increasing pressure before changing pipelines.

---

**Problem 3:** Small, inadequate flow from fixtures.

#### Possible Cause or Causes

- A Pipelines to fixtures may be too small or house main supply may be inadequate for normal fixture demand.
- B Heavy periodic demands by appliances in the house.
- C Screen clogged with debris.

#### Solution

- A It may be necessary to increase pipe sizes only in some sections of the system leading to the offending appliances or fixtures. Increasing the house service mains might be necessary if small supply is general at all fixtures.
- B Raise pressure gradually by readjusting valve until this point is determined.
- C Clean screen.

---

**Problem 4:** Valve appears to be noisy; hums, whistles, or chatters.

#### Possible Cause or Causes

- A Hum or whistle is usually caused by a high velocity of flow in pipelines causing vibration.
- B Chatter usually originates with worn seat washer or loosely installed seal ring.

#### Solution

- A Pipelines could be small or too light. Reducing valves could be too small. Pipes and valves being small would accentuate this condition.
- B Inspect seal ring. If a deep channel appears on seal ring face, replace or use the opposite side. Frequently noise appears in a faucet or appliance and seems to originate from the reducing valve. There is a general tendency to use streamline piping of a relatively small size. Velocity is naturally high and noise of fast moving water is not unusual.

Zurn Engineered Water Solutions® is a recognized leader in commercial, municipal, and industrial markets, delivering sustainable building solutions for new construction and retrofit applications. At Zurn we are committed to providing smart solutions that save both time and money. Our goal is serving the customer through innovation, continuous improvement, and assurance behind every installation. Choose Zurn for a reliable, recognized manufacturer to supply your entire installation, from behind the wall rough-in, to finish trim product and fixture systems.



**Zurn Wilkins**  
1747 Commerce Way  
Paso Robles, CA 93446, 855-663-9876

In Canada  
**Zurn Industries Limited**  
7900 Goreway Drive, Unit 10  
Brampton, Ontario L6T 5W6, 905-405-8272

1.855.ONE.ZURN | [ZURN.COM](http://ZURN.COM)

Form No. ZMKTG480-45, Rev. 11/16