



# SERVICE PARTS LIST

BULLETIN NO.  
54-24-2770

SPECIFY CATALOG NO. AND SERIAL NO. WHEN ORDERING PARTS		REVISED BULLETIN	DATE
<b>M18™ FUEL™ 1" (2Kg) SDS Plus D-Handle Rotary Hammer</b>			June 2020
CATALOG NO.	<b>2713-20</b>	STARTING SERIAL NO.	<b>H19A</b>
		WIRING INSTRUCTION	<b>SEE PAGE 6</b>

**EXAMPLE:**  
00 0 Component Parts (Small #) Are Included When Ordering The Assembly (Large #).

● = Components of the **14-46-2712** Rotary Hammer Service Kit (See page six for a complete listing)

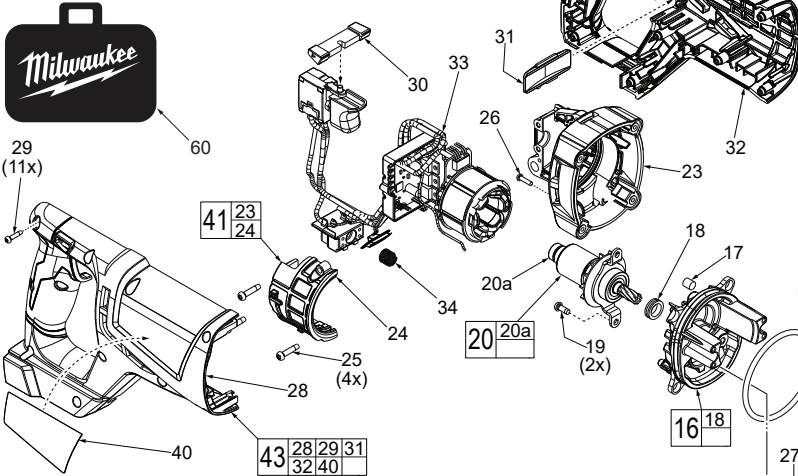

For 2713-20, Serial Break "A" tools: Spindle Sleeve Assembly (9) , Gearcase Assembly with Bearings/ Seal (7) and Crankcase Assembly (16) must be replaced together. Order Spindle Sleeve/Crankcase Service Kit (61).

FIG.	PART NO.	DESCRIPTION OF PART	NO. REQ.
1	42-52-5262	● Dust Cap	1
2	44-90-0014	● C-Ring	2
3	42-76-5264	● Chuck Assembly	1
4	02-02-0275	7mm Steel Ball	2
5	42-36-0191	Ball Plate	1
6	40-50-5262	Conical Spring	1
7	-----	Gearcase Assembly with Bearings and Seal	1
7b	-----	Spring	1
7c	-----	Locking Plate	1
8	44-10-5263	Shift Lever with O-Ring	1
9	-----	Spindle Sleeve Assembly	1
9a	-----	C-Ring	1
9b	-----	Washer	1
9c	-----	Clutch Spring	1
9d	-----	2nd Stage Gear	1
9e	-----	Clutch Plate	1
9f	-----	C-Ring	1
9g	-----	Steel Ball	3
9h	-----	Spindle	1
9j	-----	Stop Washer	1
9k	-----	● O-Ring	1
9m	-----	Striker (Anvil)	1
9n	-----	● O-Ring	1
9p	-----	Sleeve (Ram Catcher)	1
9q	-----	● O-Ring	1
9r	-----	● O-Ring	1
9s	-----	Washer	1
9t	-----	● C-Ring	1
9u	-----	Spindle Bearing	1
9v	-----	Bearing Bar Mounting Bracket	1
9w	-----	Washer	1
9x	-----	Spiral Retaining Ring	1
10	45-56-0037	Striker and O-Ring Assembly	1
10a	-----	Striker (Ram)	1
10b	34-40-1511	● O-Ring	1
11	44-62-5263	Piston	1
12	45-88-5200	● Washer	2
13	44-60-5262	Wrist Pin	1
14	05-81-1337	M4 x 14mm Pan Hd. Taptite Screw	4
15	43-44-1375	● Gasket	1
16	-----	Crankcase Assembly	1
17	43-84-0300	● Felt Plug	1
18	43-44-1376	Oil Shield	1
19	05-78-0105	M4 x 10mm Pan Hd. Taptite T-20 Screw	2
20	16-07-2713	Rotor Assembly	1
20a	02-04-0033	Ball Bearing	1
22	06-81-5383	M4 x 35mm Pan Hd. Plastite T-20 Screw	4
23	-----	Motor Housing Support - Left	1

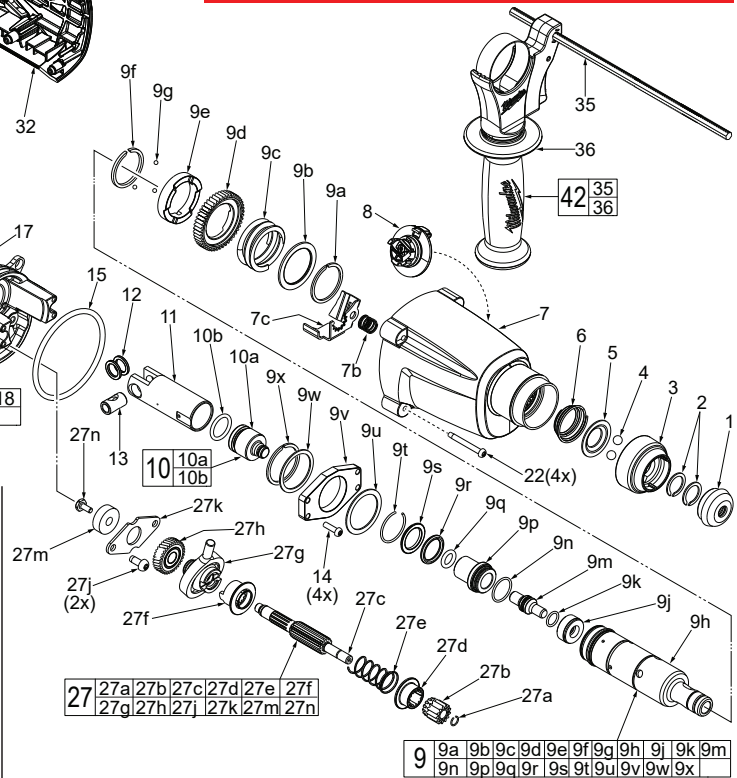
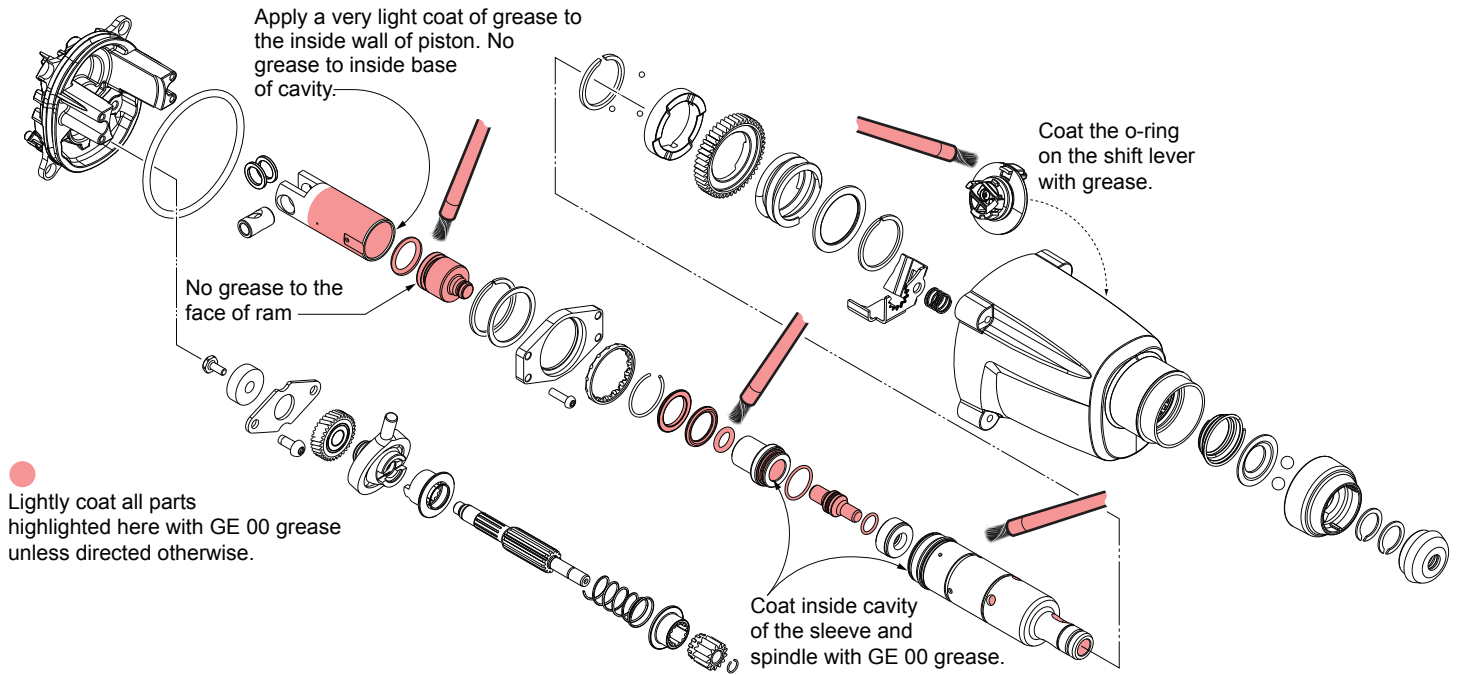

FIG.	PART NO.	DESCRIPTION OF PART	NO. REQ.
24	-----	Motor Housing Cover - Right	1
25	06-82-3006	M4 x 18mm Pan Hd. T-20 Screw	4
26	05-81-0530	Ground Wire Screw	1
27	14-73-1603	Wobble Shaft Assembly	1
27a	44-90-1180	C-Ring	1
27b	32-60-1611	Pinion	1
27c	36-66-1621	Reduction Gear Shaft	1
27d	45-22-0927	Coupling	1
27e	40-50-2141	Spring	1
27f	45-22-0926	Coupling Sleeve	1
27g	36-92-0800	Wobble Plate	1
27h	32-05-0055	Reduction Gear	1
27j	05-74-1030	M5 x 8mm Pan Hd. Tapt. T-25 Screw	2
27k	44-66-0022	Retaining Plate	1
27m	02-04-0005	Ball Bearing	1
27n	06-82-0017	● M4 x 10mm Hex Head Screw	1
28	-----	D-Handle Housing Cover	1
29	06-82-1080	M3 x 14mm Pan Hd. Plastite T-10 Screw	11
30	45-24-1022	Forward / Reverse Shuttle	1
31	-----	FUEL™ Housing Plate	1
32	-----	D-Handle Housing Support	1
33	14-20-2713	Electronics Assembly	1
34	40-50-1090	Terminal Spring	1
35	44-94-5381	Depth Gauge	1
36	14-34-0650	Auxiliary Side Handle	1
40	12-20-2713	Service Nameplate	1
41	31-50-2713	Motor Housing Assembly	1
42	14-46-1450	Side Handle Assembly	1
43	31-44-2713	D-Handle Housing Assembly	1
60	42-55-2713	Blow Molded Carrying Case	1
	14-46-2712	Rotary Hammer Service Kit (See page 6)	1
61	14-46-0251	Spindle Sleeve/Crankcase Kit	1

**LUBRICATION NOTES:** Type GE 00 Urethyn Grease  
No. 49-08-5355, 2.8 oz./80g tube

**NOTE:** The entire contents of the grease tube will not be used. Use a total of approximately 3/16 oz./5.4g.



**LUBRICATION NOTES:** Type 'S2' Grease  
No. 49-08-5265,  
7.0 oz./198g tube

**NOTE:** The entire contents of the grease tube will not be used. Use a total of approximately 2.8 oz./80g.

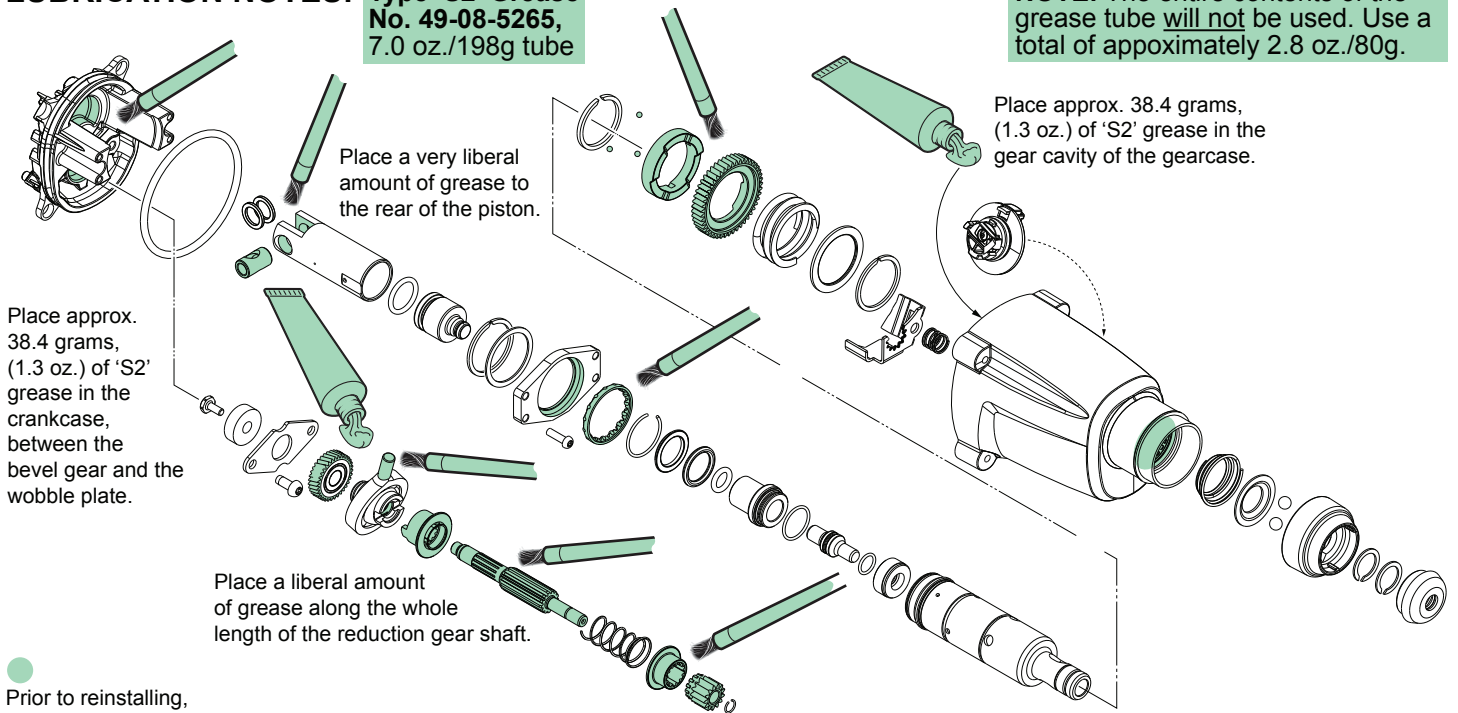

**SERVICE NOTES** on pages 3, 4 and 5 are included for general servicing of the tool and **ARE NOT** complete step by step instructions.

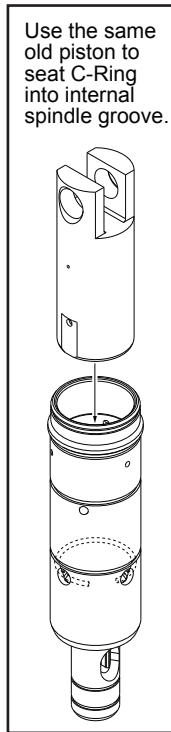
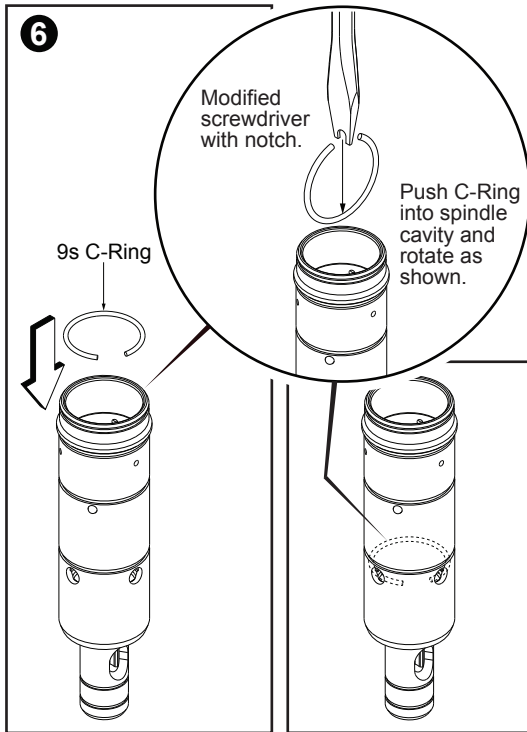
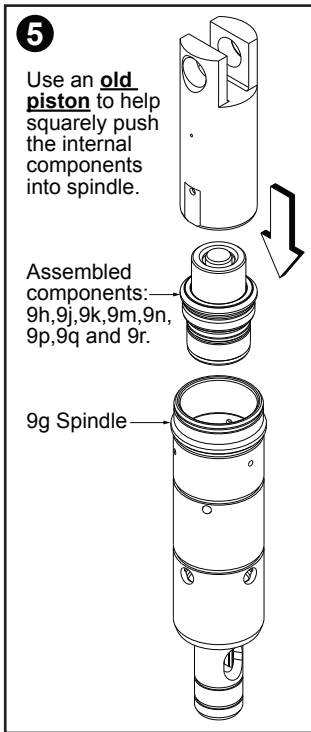
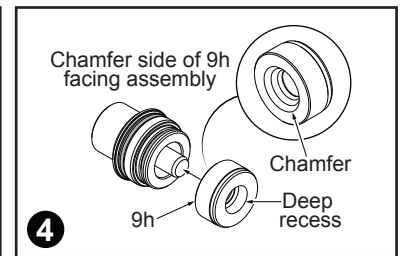
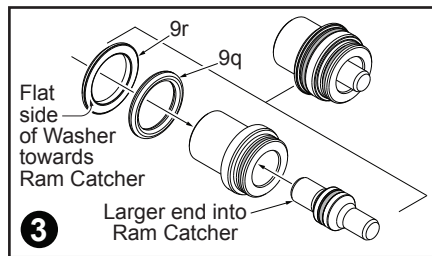
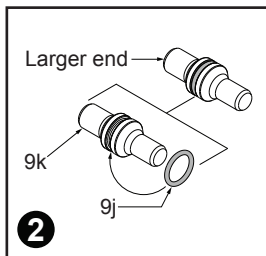
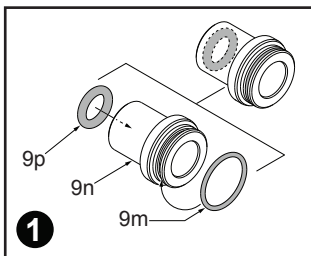

- Assembly of internal Spindle components:**
1. Lubricate Ram Catcher and O-Rings. Assemble O-Rings onto and into Ram Catcher.
  2. Lubricate Striker and O-Ring. Assemble O-Ring onto Striker.
  3. Assemble Striker Assembly into Ram Catcher Assembly (large end into Ram Catcher as shown).
  4. Place the chamfered end of the Stop Washer over the small end of the Striker.
  5. Place the assembled components from step 4 into the cavity of an old piston as shown. Use the old piston as an aid to push the assembled components deep into the Spindle cavity.
  6. C-Ring (9s) will be used to secure the internal components inside the spindle. *It is recommended to modify a flat blade screwdriver by filing or grinding a notch into the blade.* Place the C-Ring upright as shown with the opening of the ring straight up. Use the modified screwdriver to push the C-Ring down into the Spindle cavity. Rotate the C-Ring in the spindle cavity as shown. Place the old piston into the Spindle cavity and tap the piston with a mallet to secure the C-Ring in the groove.

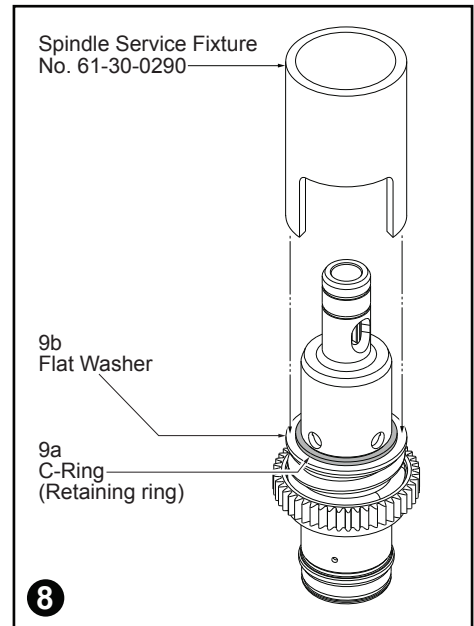
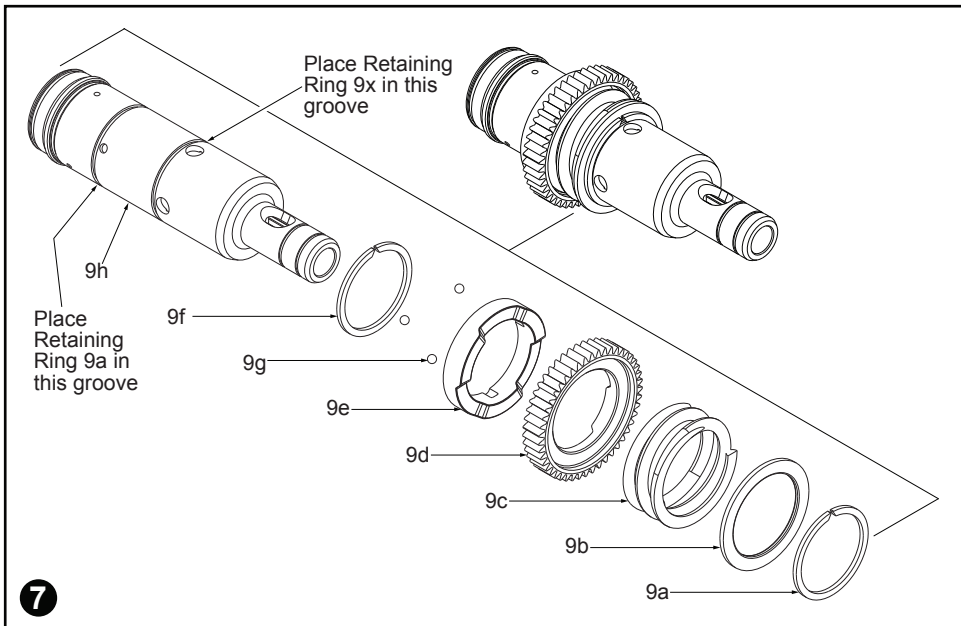

**Assembly of external Spindle components:**

7. Place C-Ring 9f onto Spindle. With the aid of a snap ring pliers, work the C-Ring into the rear most spindle groove and snap into place.

As an aid, put a dab of grease on your finger to pick up and place the three Steel Balls 9g into the three small holes on the Spindle just above the previously installed C-Ring.

Lubricate and install the Clutch Plate 9e onto the Spindle. Be sure to orient the part as shown and position with the three notches on the back of the plate over the three steel balls.

Lubricate and install the Clutch Gear 9d. Place the Clutch Spring 9c over the Clutch Gear and the Washer 9b over the Spring.

Place C-Ring 9a onto Spindle. With the aid of a snap ring pliers, work the C-Ring down to the other parts assembled onto spindle.

8. Place Spindle Service Fixture 61-30-0290 over the assembled parts and the spindle. Position so the fixture rests on Flat Washer 9b. Place the fixture and spindle assembly in an arbor press and carefully compress the Clutch Spring enough to expose the spindle groove for C-Ring 9a.

While compressed, use a screwdriver to work C-Ring 9a into the groove.



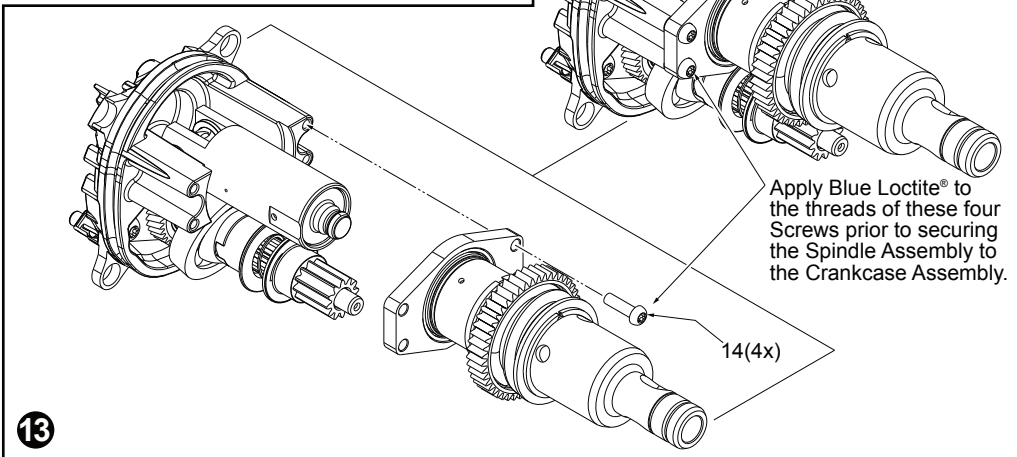
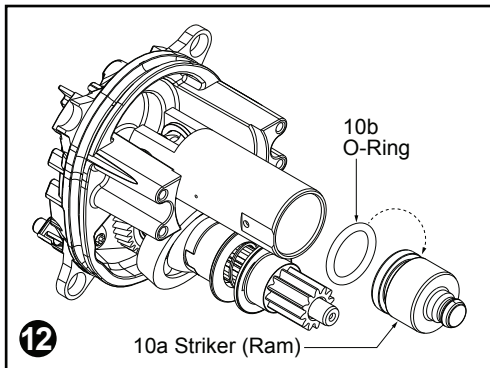
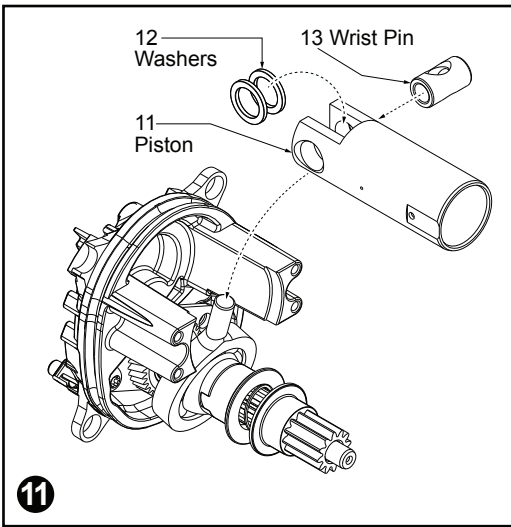
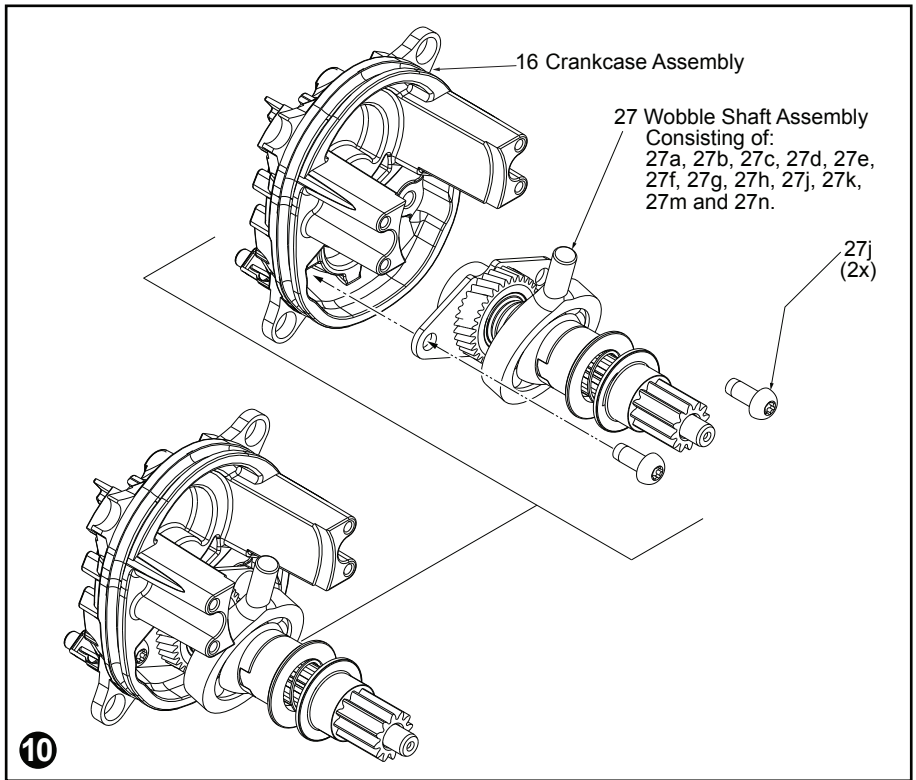
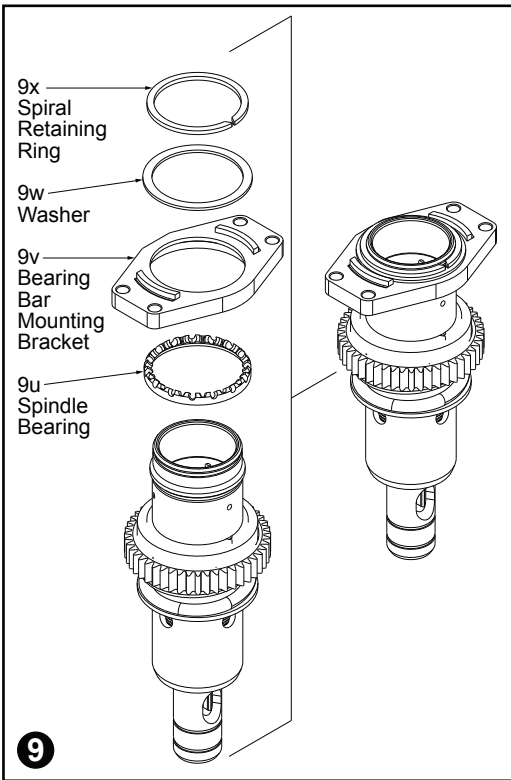

9. The flat side of the Bearing Bar 9v has a rounded recess area that will receive the Spindle Bearing 9u. Coat the recess area and place the Spindle Bearing in the recess. Place the two parts onto the Spindle Assembly as shown. Next place the Washer 9w on top of the Bearing Bar and secure with Spiral Retaining Ring 9x.

**Mounting the Spindle Assembly onto the Crankcase Assembly**

10. Lubricate the inside cavity of the Crankcase Assembly 16 with grease. Place Wobble Shaft Assembly into Crankcase Assembly as shown. Secure assembly with screws 27j.

11. Place Washers 12 and Wrist Pin 13 into rear area of Piston 11. While holding those parts in place, be sure the Washers are separated, one on each side of the hole in the Wrist Pin. Connect the Piston Assembly to the Wobble Shaft Assembly by sliding the hole on the Wrist Pin over the arm on the wobble bearing.

12. Lubricate O-Ring 10b and Striker (Ram) 10a. Be sure not to have any lubrication on the rear (flat side) of Striker. Place O-Ring onto Striker 10a. Insert assembled parts into Piston 11 as shown.

13. Mount the Spindle Assembly onto The Crankcase Assembly by inserting the Piston into the Spindle. Use four Screws to secure the Spindle Assembly to the Crankcase Assembly. **NOTE:** Prior to installing screws, place a few drops of Blue Loctite® thread locking sealant to the threads.

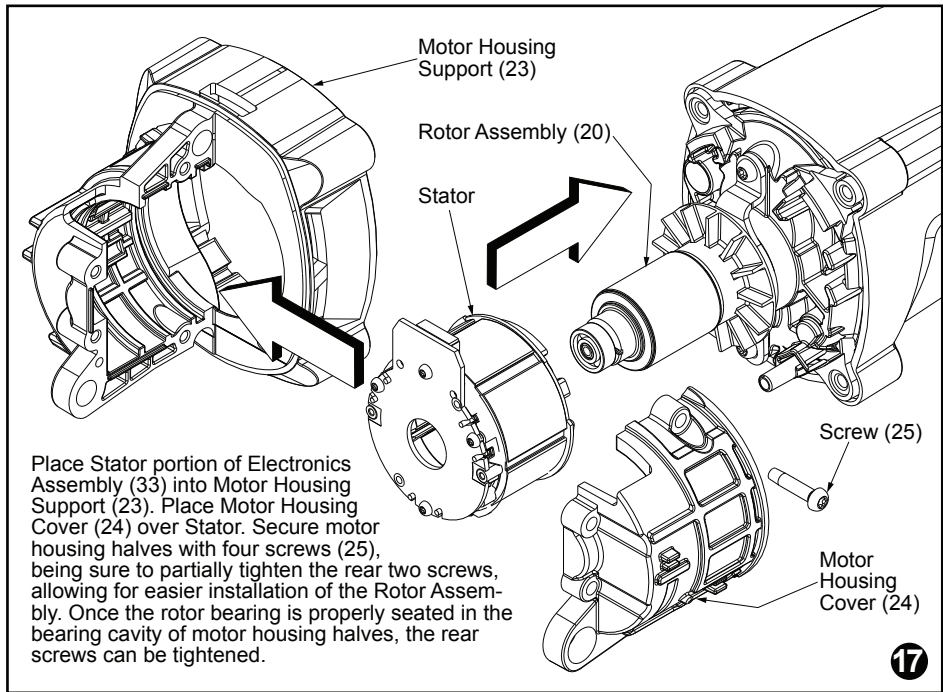
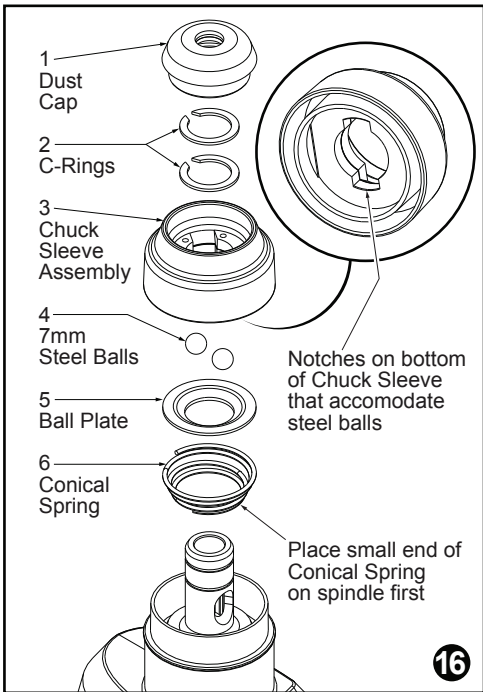
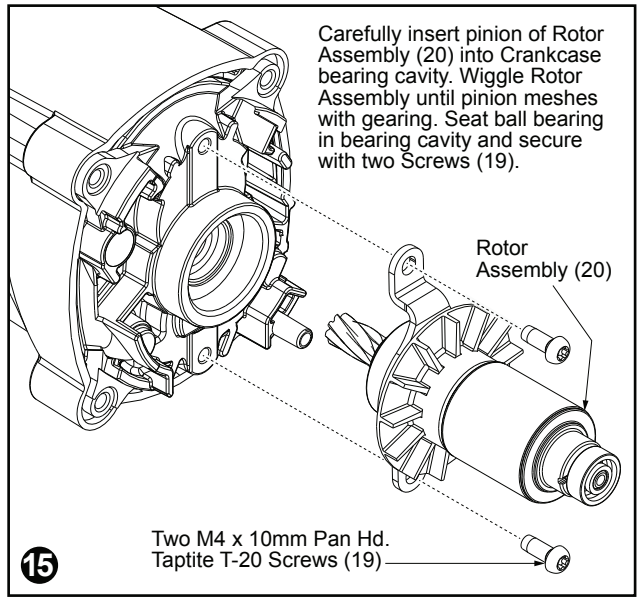
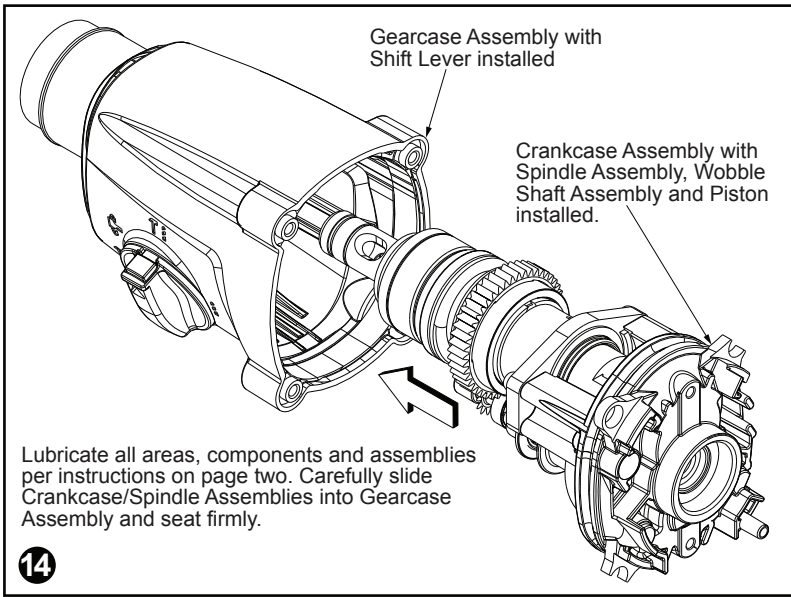

Forward/Reverse Shuttle

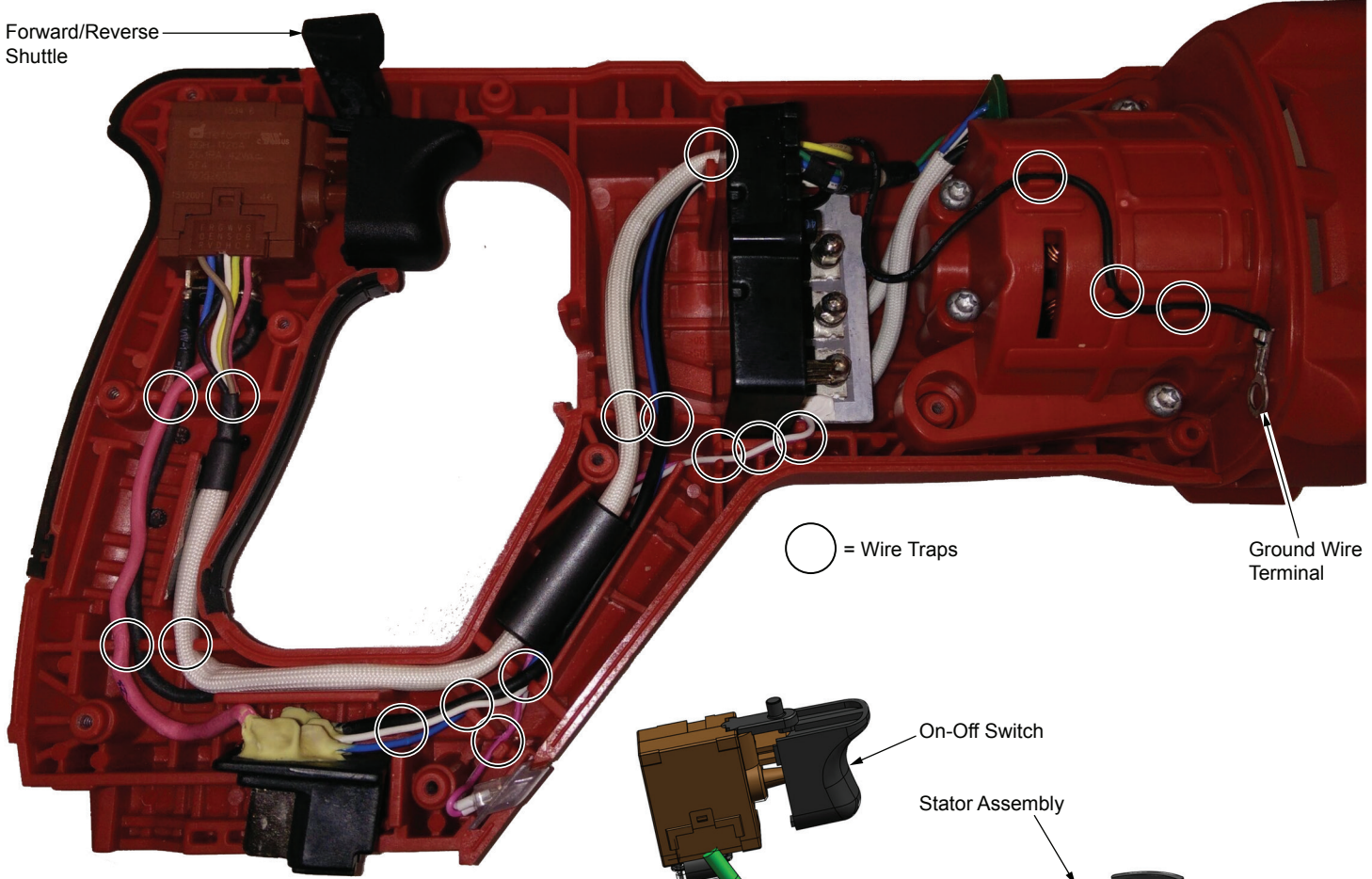

Route wires as shown being very careful to tuck all wires down into traps.

Be sure that all components of the electronics assembly are firmly and squarely seated in the housing support.

Be careful that there are no pinched wires when assembling housing cover. Check for proper switch and shuttle functionality before tightening all screws.

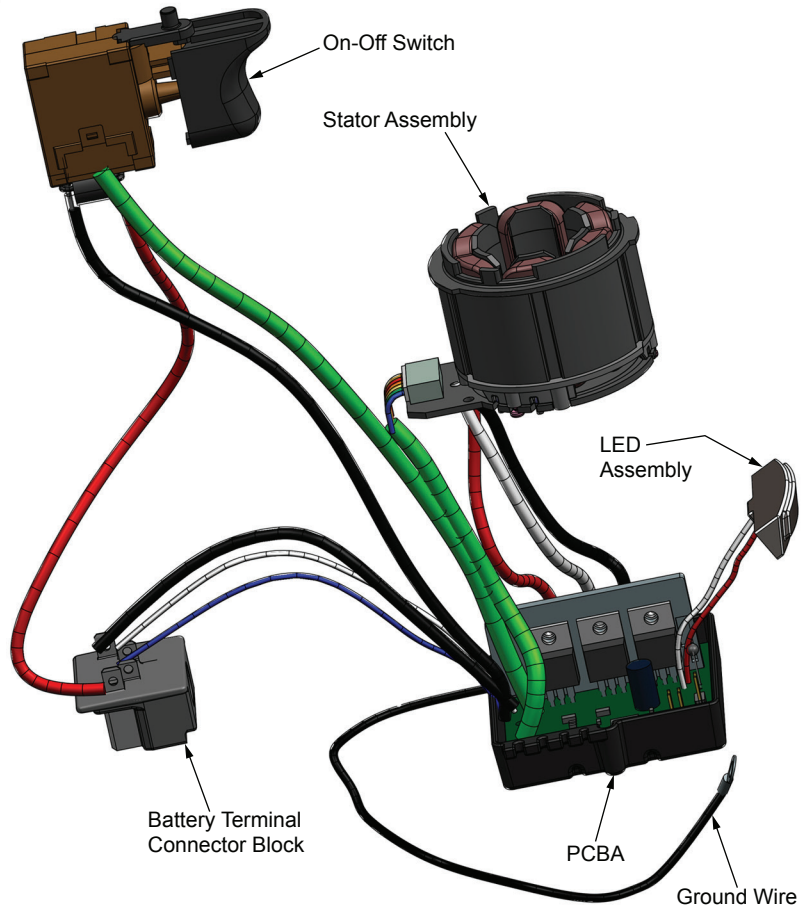

●14-46-2712

**Rotary Hammer Service Kit**

1	42-52-5262	Dust Cap	1
2	44-90-0014	C-Ring	2
3	42-76-5264	Chuck Sleeve Assy.	1
9a	44-90-0216	C-Ring	1
9k	34-40-1410	O-Ring	1
9n	34-40-1425	O-Ring	1
9r	34-40-1450	O-Ring	1
9q	34-40-1440	O-Ring	1
9t	44-90-1026	C-Ring	1
10b	34-40-1511	O-Ring	1
12	45-88-5200	Washer	2
15	43-44-1375	Gasket	1
19	43-84-0300	Felt Plug	1
27n	06-82-0017	Screw	1
	49-08-5355	Type GE 00 Urethyn Grease 2.8 oz Tube	1
	49-08-5265	Type S2 Grease 7.0 oz Tube	1

**SCREW TORQUE SPECIFICATIONS**

FIG.	PART NO.	WHERE USED	SEAT TORQUE	
			(KG/CM)	(IN/LBS)
14	05-81-1337	Motor Housing Assembly	35-40	30-34
14	05-81-1337	Bearing Bar Mounting Bracket	35-40	30-34
20	05-74-1020	Crankcase Assembly	18-23	15-20
22	05-81-1338	Bearing Retainer	35-40	30-34
24	05-88-1525	Gear Housing Cover	15	13
26	06-82-3006	Motor Housing Assembly	35-40	30-34
31	06-82-3007	Rotor Assembly	25-30	21-26
39	06-82-1080	Handle Cover - Right Halve	14-17	12-14