



SERVICE PARTS LIST

BULLETIN NO.
54-42-0020

SPECIFY CATALOG NO. AND SERIAL NO. WHEN ORDERING PARTS		REVISED BULLETIN	DATE
M18™ FUEL™ DRYWALL SCREWDRIVER			Oct. 2016
CATALOG NO.	2866-20	STARTING SERIAL NO.	H47A
		WIRING INSTRUCTION See Page 2	

EXAMPLE:
Component Parts (Small #) Are Included
When Ordering The Assembly (Large #).

FIG.	PART NO.	DESCRIPTION OF PART	NO. REQ.
1	48-32-3065	Magnetic Bit Holder	(1)
8	02-80-0055	Thrust Bearing	(1)
17	40-50-0132	Bit Retaining Spring	(1)
18	02-02-0130	9/64" Steel Ball	(1)
20	45-88-0204	Thrust Bearing Washer	(1)
21	40-50-0142	Conical Spring	(1)

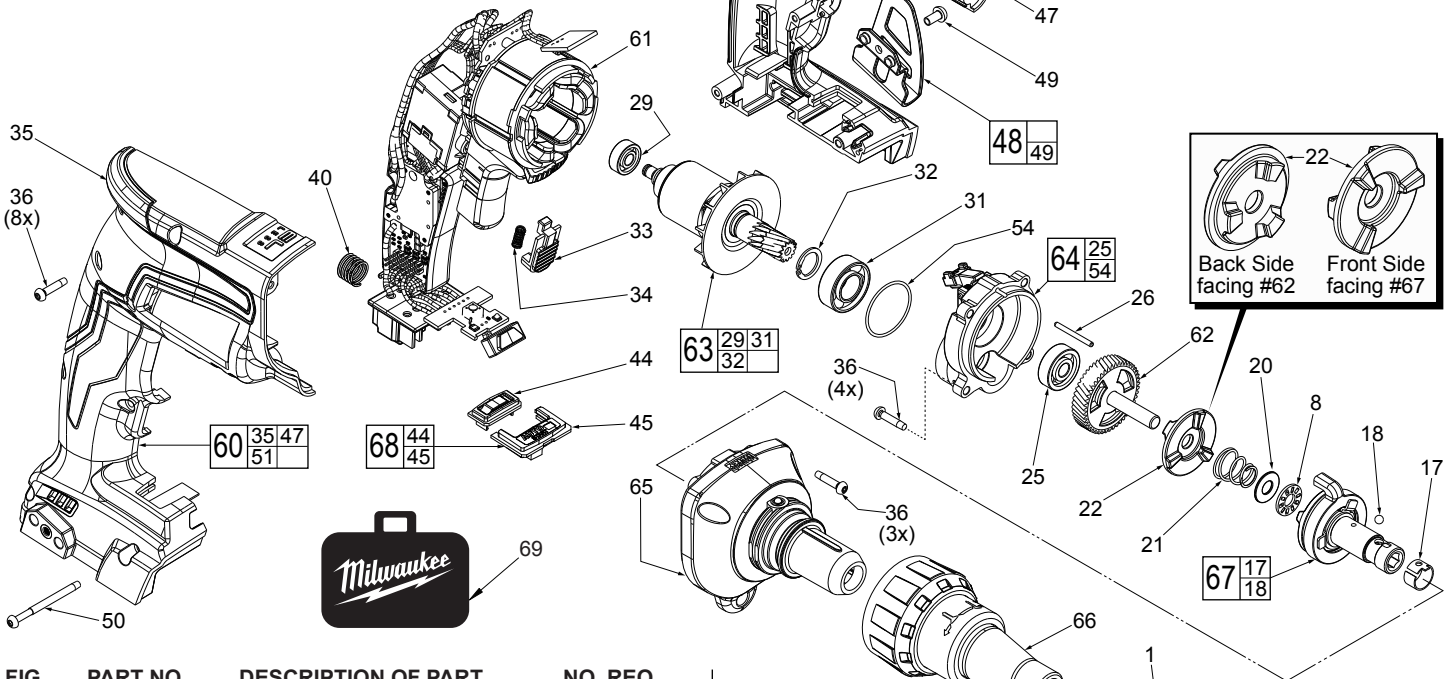

FIG.	PART NO.	DESCRIPTION OF PART	NO. REQ.
22	42-70-0222	Drive Clutch	(1)
25	02-04-0640	Ball Bearing	(1)
26	44-60-0412	Pin	(1)
28	-----	Screwdriver Bit	(1)
29	02-04-0033	Ball Bearing	(1)
31	02-04-0701	Ball Bearing	(1)
32	34-60-0575	Retaining Ring	(1)
33	31-15-0022	Lock-On Slide Lever	(1)
34	40-50-0422	Lock-On Spring	(1)
35	-----	Right Housing Halve-Housing Cover	(1)
36	06-82-1080	M3 x 14mm Pan Hd. ST T-10 Screw	(15)
40	40-50-1090	Terminal Block Spring	(1)
44	-----	Auto Start Button	(1)
45	-----	Auto Start Plate	(1)
47	-----	Left Housing Halve-Housing Support	(1)
48	42-70-0059	Belt Clip Kit	(1)
49	06-82-0130	6-32 x 5/16" Pan Hd. T-15 Mach. Scr.	(1)
50	06-82-0013	M3 x 38mm Pan Hd. ST T-10 Screw	(1)
51	12-20-0101	Service Nameplate	(1)
54	34-40-0076	O-Ring	(1)
60	31-44-1086	Housing Set	(1)
61	14-20-2866	Electronics Assembly Consisting of: Stator, Main PCBA, On-Off Switch, LED, Mode Selector PCBA and Battery Connector Block	(1)
62	32-10-0057	Clutch Gear Assembly	(1)
63	16-07-0212	Rotor Assembly	(1)
64	28-14-0711	Rear Gearcase Assembly	(1)
65	28-14-0712	Front Gearcase Assembly	(1)
66	49-26-1090	Nosecone Assembly	(1)
67	42-66-0025	Clutch Chuck Assembly	(1)
68	45-24-0305	Auto Start Assembly	(1)
69	42-55-2866	FUEL™ Small Contractor Bag	(1)
	10-20-1048	French/Spanish Warning Label (Not Shown)	(1)

LUBRICATION NOTE:

When servicing this tool, 90-95% of the old grease must be removed prior to new grease being added.

LUBRICATION

(Type "Y" Grease, No. 49-08-5270)

- Place a light coat of grease in the bottom inside cavity of rear gearcase (64) and over ball bearing (25). Use about .5 grams.
- Fill the 3 enlarged clutch pockets of the clutch gear assembly (62) with .5 grams grease. Install drive clutch (22).
- Add approximately 4.3 grams of grease into the rear gearcase, around the teeth of the armature pinion and the teeth of the clutch gear. Place a heavy coat of grease over the drive clutch (22).
- Coat with grease the thrust bearing (8), thrust bearing washer (20) and conical spring (21).
- Apply a light film of grease to the lead chamfer and barrel of the clutch chuck (67) prior to assembly into front gearcase (65).
- With clutch chuck (67) installed in the front gearcase (65), add approximately 3 grams of grease over the lugged surfaces of clutch chuck.

Seat the Stator in the housing half, being sure the grooves on each side of the stator fits onto the corresponding ribs in the housing halves.

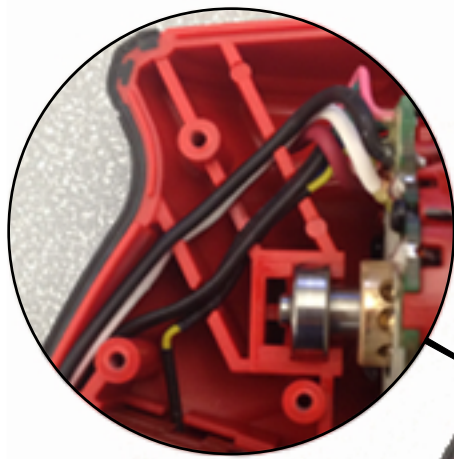

Seat firmly and squarely the On-Off Switch, the Main Potted PCBA and Battery Connector Block. Be sure to route wires behind the On-Off Switch as shown.

Route wires from the Electronics Assembly as shown. Avoid pinched wires by placing the wires firmly down in the traps.

Be careful not to pinch any wires when installing the Housing Cover.

Be sure that Hall Sensor is completely seated in handle half



Be sure Auto Start Assembly / PCBA and LED Work Light Lens are completely seated in handle half

