



Ductile Iron MJ Compact Fittings

ANSI/AWWA C153/A21.53

GENERAL SPECIFICATIONS

- MATERIAL: Ductile Iron per ASTM A536
PRESSURE: 350 PSI rating for 2" - 24" sizes, 250 PSI rating for 30" - 48" sizes and 150 PSI rating for 54" - 64" sizes
TESTING: In accordance with ANSI/AWWA C153/A21.53, ANSI/AWWA C111/A21.11, UL and FM requirements
LAYING LENGTH: In accordance with ANSI/AWWA C153/A21.53 (fittings not listed in ANSI/AWWA have dimensions per Star design as noted in the catalog)
DEFLECTION: 2"-4"=8° | 6"=7° | 8"-12"=5° | 14"-16"=3 1/2° | 18"-24"=3° | 30"-64"=2°
WEIGHTS: Are in pounds, unless noted otherwise and do not include accessories, cement lining and coating
FLANGES: Flanged ends on fittings match ANSI/AWWA C115/A21.15 and ANSI B16.1 class 125 flanges
CEMENT LINING: In accordance with ANSI/AWWA C104/A21.4 -- size 2" - 3" single thickness and sizes 4" - 64" double thickness
COATING: Asphaltic seal coat inside and out in accordance with ANSI/AWWA C104/A21.4 and referenced in ANSI/AWWA C153/A21.53
GASKETS: SBR in accordance with ANSI/AWWA C111/A21.11
T-BOLTS/NUTS: Low alloy steel in accordance with ANSI/AWWA C111/A21.11
APPROVALS: 3" - 12" UL/ULC Listed | 2" and greater are UL/ANSI/NSF Standards 61 and 372 | 3" - 16" FM APPROVED. Please consult factory for detail listing and approvals.
DIMENSIONS: All dimensions are in inches unless noted otherwise.
INSTALLATION: Per ANSI/AWWA C600 and C111 using DIP conforming to C150/C151 and PVC pipe conforming to C900/C905



SUBMITTAL INFORMATION
PROJECT NAME:
ENGINEER:
CONTRACTOR:
SPEC. SECTION:

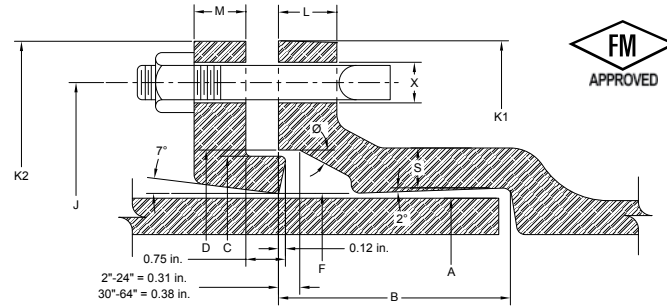

MECHANICALJOINT DIMENSIONS

Table with columns: NOM. SIZE, A DIA., B, C DIA., D DIA., F DIA., J DIA., K1 DIA., K2 DIA., L, M, S, Ø, X DIA., BOLTS (SIZE, NO.). Rows include sizes from 2 to 64 inches.

SIZE RANGE (Please specify):
Size Range _____

LINING OPTIONS (Please check one):
Standard: Cement-lined and asphalt seal coat per ANSI/AWWA C104/A21.4 and UL/NSF-61
Optional: FBE (Fusion Bonded Epoxy) per ANSI/AWWA C116/A21.15 and UL/NSF-61 - ID & OD Only
Optional: P401 (Protecto 401) Ceramic Epoxy - sewer applications only. Not NSF-61
Optional: Other (specify) _____

COATING OPTIONS (Please check one):
Standard: Asphaltic seal coat per ANSI/AWWA C104/A21.4
Optional: FBE (Fusion Bonded Epoxy) per ANSI/AWWA C116/A21.15 and UL/NSF-61 - ID & OD Only
Optional: Other (specify) _____

