

HT-10EN HIGH TEMPERATURE - 1/2 HP

APPLICATIONS

Boiler blow-down, effluent wastewater removal, sump pits, transformer vaults

FEATURES

- Rated for continuous duty use dewatering, water transfer, and effluent wastewater removal applications
- Energy-efficient PSC motor with thermal overload protection
- Handles liquids up to 200 °F (93 °C)
- Heavy duty epoxy coated cast iron housing
- Solids handling up to 3/4" diameter
- cCSAus listing



SERIES SPECIFICATIONS

Volts	Hz	Amps		Watts	Performance (GPM @ Height in Feet)					Shut-Off (ft)	PSI
		FLA	Start		5'	10'	15'	20'	25'		
115	60	10.5	21	900	75	65	60	40	20	30	13

Item No.	Model	HP	Volts	Switch Type/ Operation	On Level	Off Level	Cord	Weight
511710	HT-10EN-CIA-FS	1/2	115	Integral Mechanical Float	9" - 14" 22.86 cm - 35.56 cm	2" - 4" 5 cm - 10.2 cm	15' 4.6 m	39 lbs 17.7 Kg
511610	HT-10EN-CIM	1/2	115	Manual	-	-	15' 4.6 m	38 lbs 17.24 Kg

EFFLUENT PUMPS

HT-10EN HIGH TEMPERATURE - 1/2 HP

ENGINEERING DATA

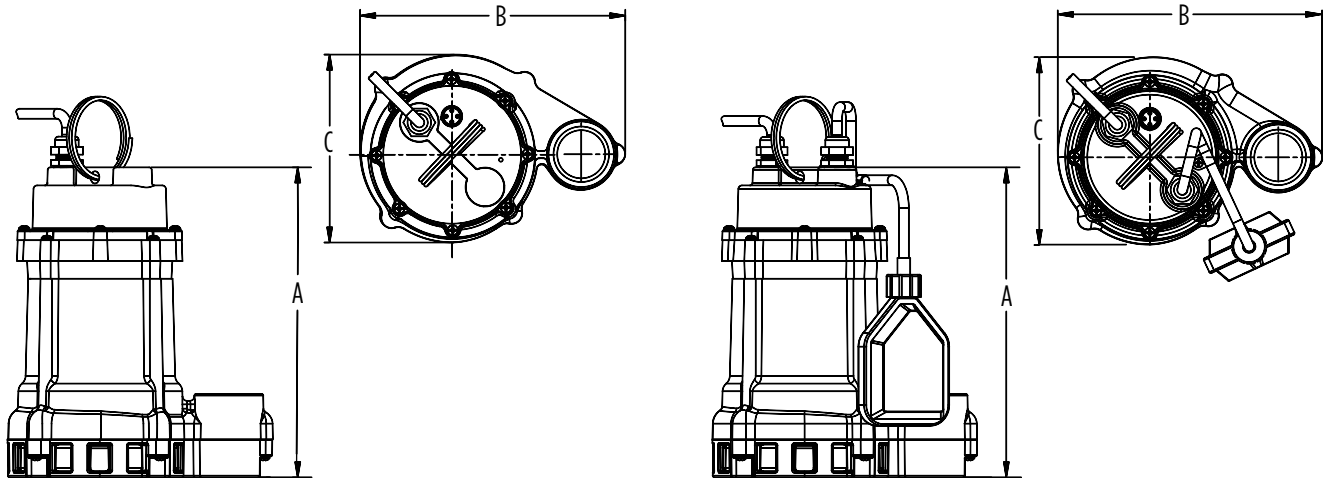

Model	A	B	C
HT-10EN-CIA-FS	11.16" 28.35 cm	9.56" 24.28 cm	6.77" 17.20 cm
HT-10EN-CIM	11.16" 28.35 cm	9.56" 24.28 cm	6.77" 17.20 cm

PERFORMANCE DATA

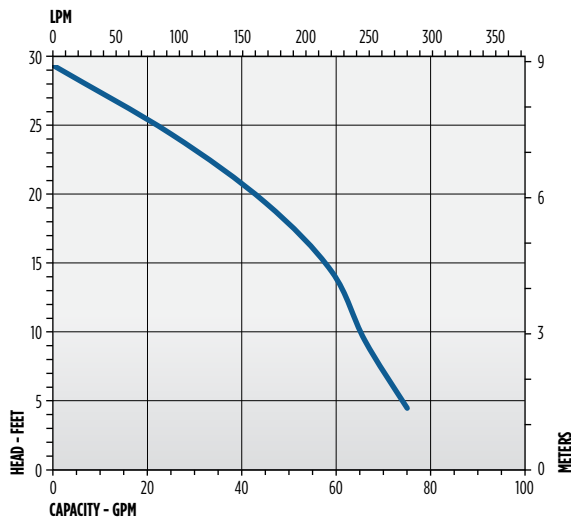

CONSTRUCTION

Motor Housing	Epoxy-coated cast iron
Impeller Material	Nylon
Impeller Type	Non-clog
Volute	Epoxy-coated cast iron
Mechanical Shaft Seal	Fluoroelastomer (FKM) with carbon and Ni-resist faces
Fasteners	Stainless steel
Shaft	Steel
Bearings	Upper and lower ball bearings
Power Cord	SJTW