



SERVICE PARTS LIST

BULLETIN NO.
54-07-3510

SPECIFY CATALOG NO. AND SERIAL NO. WHEN ORDERING PARTS		REVISED BULLETIN	DATE
REDLITHIUM® USB 3 Point Laser			Jan. 2022
CATALOG NO. 3510-20	STARTING SERIAL NO. L39A	WIRING INSTRUCTION	

Service needs pertaining to accuracy or calibration can only be performed at Milwaukee Authorized Repair Centers: MILWAUKEE ELECTRIC TOOL central repair 1401 Sycamore Ave. Greenwood, MS 38930-7277 OR Via e-Service at: www.milwaukeetool.com/e-service. Questions, please call 1.800.SAWDUST OR Return it to a MILWAUKEE FACTORY SERVICE CENTER location, freight prepaid and insured. A copy of the proof of purchase should be included with the return product.*

EXAMPLE:

00	0
----	---

 Component Parts (Small #)
 Are Included When Ordering
 The Assembly (Large #).

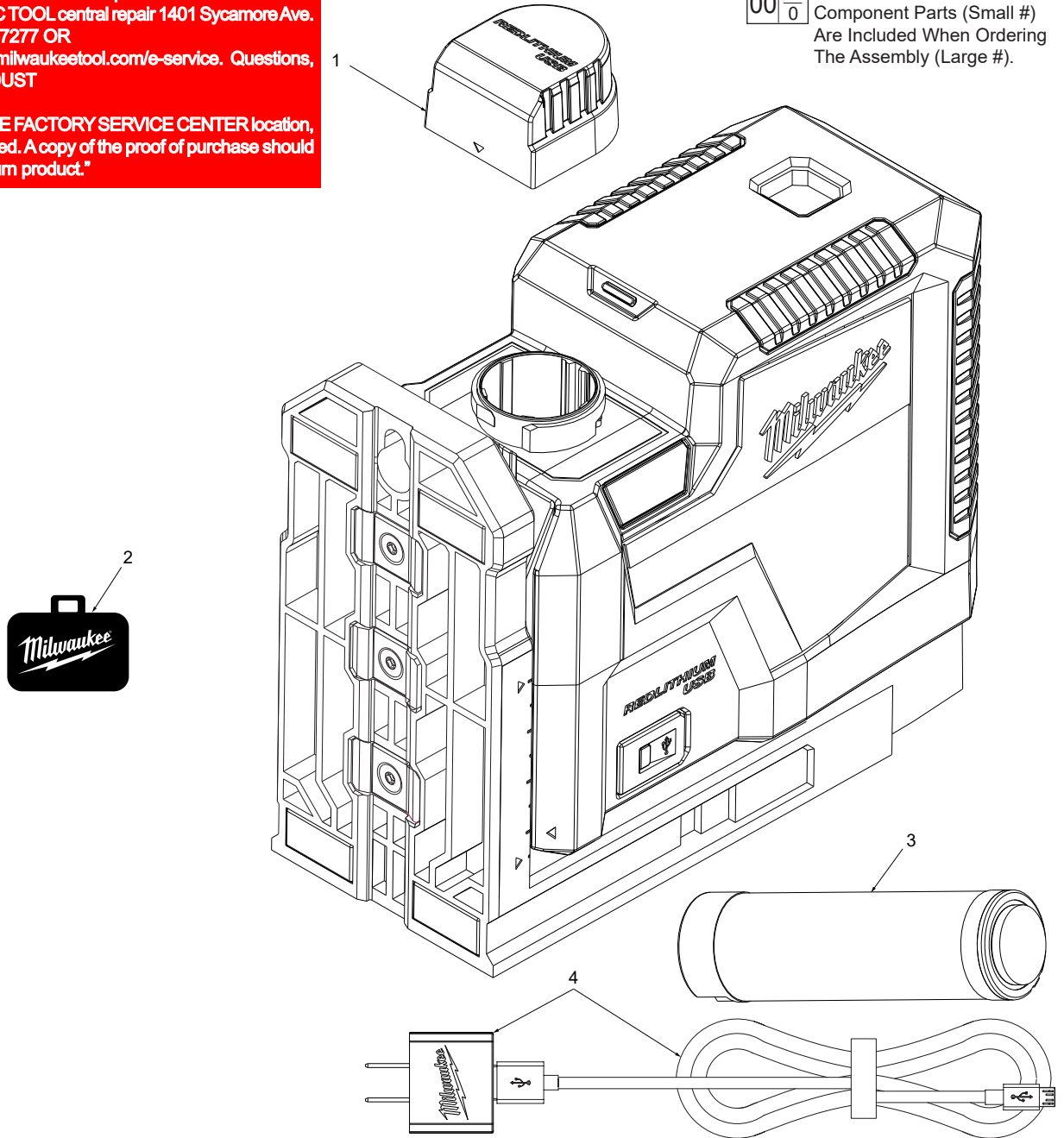

FIG.	PART NO.	DESCRIPTION OF PART	NO. REQ.
1	42-92-0118	Battery Cap	(1)
2	42-55-0205	BMC	(1)
3	48-11-2131	REDLITHIUM® USB 3.0AH Battery (Optional)	(1)
4	48-59-1202	Wall Plug and 3 ft. USB Cable (Optional)	(1)
5	12-20-3510	Service Nameplate (Not Shown)	(1)

FIG. 5 NOTES
 A clean, dry surface is essential for proper performance for any adhesive system. The area intended for application of any adhesive label or nameplate must be prepared by cleaning with isopropyl alcohol. The solvent is to be applied with a clean, lint free applicator and the surface allowed to dry before applying the label or name plate.