

Beading Bits

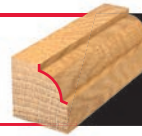

EDGE TREATMENT & GROOVING BITS



USE IN



Table Router Hand Router

APPLICATION

Add a decorative bead profile to furniture and millwork. For rounding over work, add a 1/8" larger bearing and step washer.

MATERIALS



Hardwood

Softwood

MDF

Plywood

ROUTER BITS

ITEM NUMBER	OVERALL DIA.	BEARING DIA.	CARBIDE HEIGHT	LARGE RADIUS	SHANK DIA.	OVERALL LENGTH
36-100	5/8"	3/8"	1/2"	1/16"	1/4"	2-3/16"
36-104	3/4"	3/8"	1/2"	1/8"	1/4"	2-3/16"
36-106	13/16"	3/8"	1/2"	5/32"	1/4"	2-3/16"
36-108	7/8"	3/8"	1/2"	3/16"	1/4"	2-3/16"
36-110	1-1/8"	1/2"	1/2"	1/4"	1/4"	2-3/16"
36-112	1-1/4"	1/2"	1/2"	5/16"	1/4"	2-3/16"
36-114	1-3/8"	1/2"	5/8"	3/8"	1/4"	2-3/16"
36-116	1-1/2"	3/8"	3/4"	1/2"	1/4"	2-1/2"
36-117	5/8"	3/8"	1/2"	1/16"	1/2"	2-1/2"
36-118	3/4"	3/8"	1/2"	1/8"	1/2"	2-1/2"
36-119	7/8"	3/8"	1/2"	3/16"	1/2"	2-1/2"
36-120	1-1/4"	5/8"	1/2"	1/4"	1/2"	2-1/2"
36-122	1-1/8"	5/8"	1/2"	5/16"	1/2"	2-1/2"
36-124	1-1/2"	5/8"	5/8"	3/8"	1/2"	2-5/8"
36-126	1-5/8"	1/2"	3/4"	1/2"	1/2"	2-3/4"
36-127	1-7/8"	1/2"	7/8"	5/8"	1/2"	2-7/8"
36-128	2"	3/8"	1"	3/4"	1/2"	2-7/8"
36-130	2-1/4"	3/8"	1-1/4"	7/8"	1/2"	3-1/8"
36-132	2-1/2"	3/8"	1-1/4"	1"	1/2"	3-1/8"
36-134	2-3/4"	3/8"	1-3/8"	1-1/8"	1/2"	3-1/4"
36-136	3"	3/8"	1-1/2"	1-1/4"	1/2"	3-3/8"
36-138	3-1/4"	3/8"	1-9/16"	1-3/8"	1/2"	3-3/8"

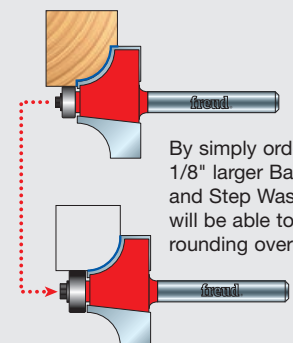
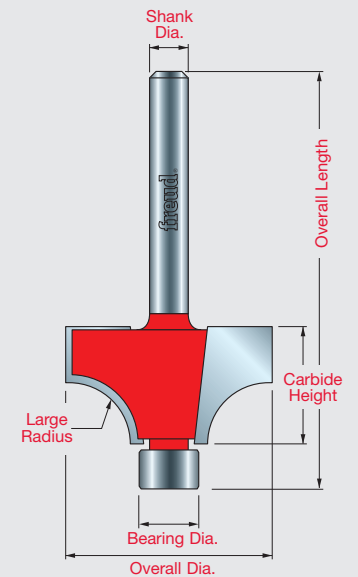
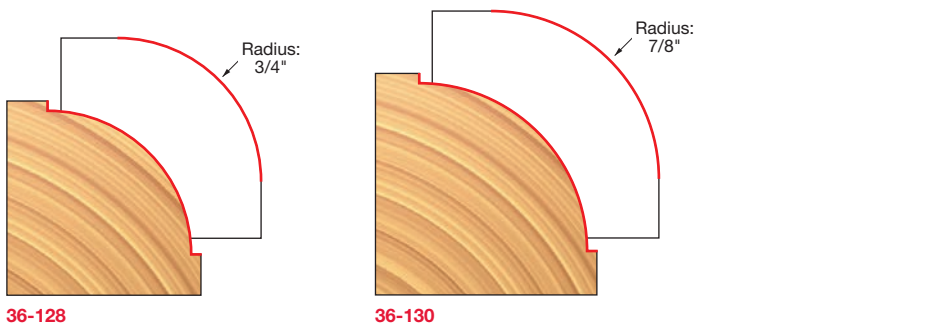
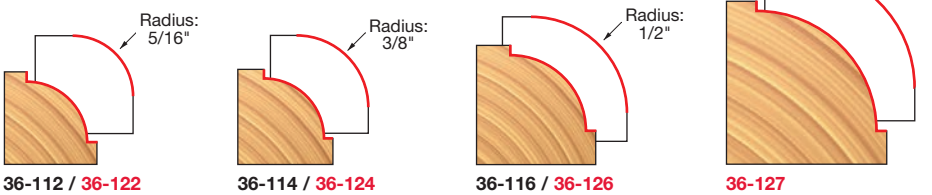
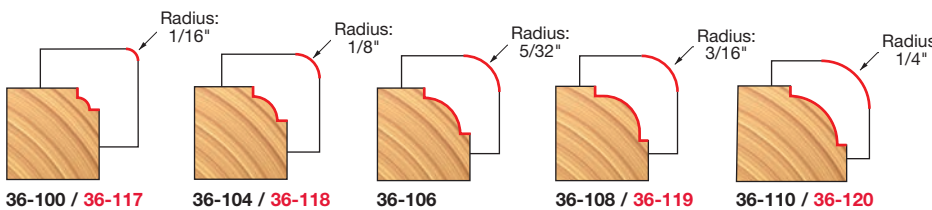

By simply ordering the 1/8" larger Ball Bearing and Step Washer you will be able to obtain a rounding over profile.