

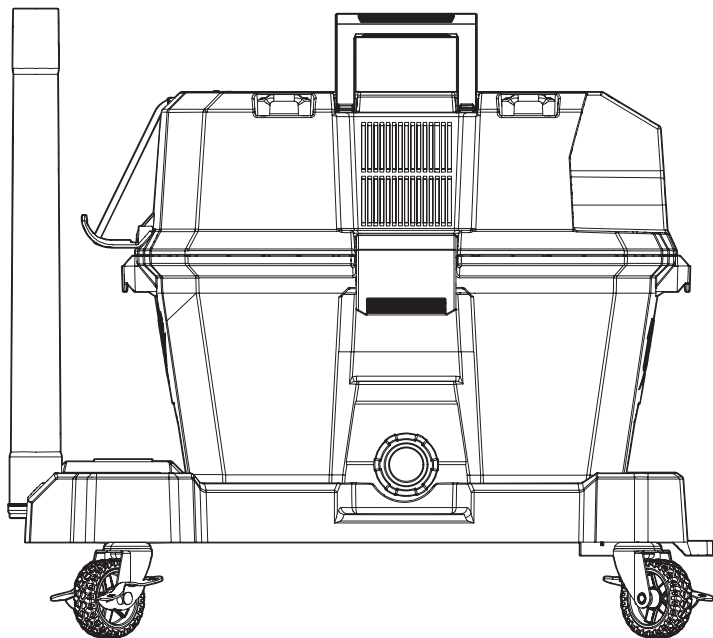

**OPERATOR'S MANUAL
MANUEL de L'UTILISATEUR
MANUAL del OPERADOR**



**Cat. No. / No de cat.
0910-20, 0911-20**

M18 FUEL™ 6 GALLON WET/DRY VACUUM

M18 FUEL™ WET/DRY VACUUM MOTOR HEAD

ASPIRATEUR DE DÉTRITUS SECS ET HUMIDES DE 23 L

(6 GAL) M18 FUEL™

TÊTE DU MOTEUR DE L'ASPIRATEUR DE DÉTRITUS SECS /

ET HUMIDES M18 FUEL™

ASPIRADORA DE RESIDUOS SECOS Y HÚMEDOS DE 23 L

(6 GAL) M18 FUEL™

CABEZAL DE MOTOR DE LA ASPIRADORA DE RESIDUOS

SECOS Y HÚMEDOS M18 FUEL™



WARNING To reduce the risk of injury, user must read and understand operator's manual.



AVERTISSEMENT Afin de réduire le risque de blessures, l'utilisateur doit lire et bien comprendre le manuel.

ADVERTENCIA Para reducir el riesgo de lesiones, el usuario debe leer y entender el manual.

IMPORTANT SAFETY INSTRUCTIONS

⚠️WARNING WHEN USING AN ELECTRICAL VACUUM, BASIC PRECAUTIONS SHOULD ALWAYS BE FOLLOWED. BEFORE USING THE VACUUM, READ THIS OPERATOR'S MANUAL, BATTERY PACK AND CHARGER OPERATOR'S MANUALS, AND ALL LABELS ON THE VACUUM, BATTERY PACK, AND CHARGER. FAILURE TO FOLLOW THE WARNINGS AND INSTRUCTIONS MAY RESULT IN ELECTRIC SHOCK, FIRE AND/OR SERIOUS INJURY.

WORK AREA SAFETY

- Keep work area clean and well lit. Cluttered or dark areas invite accidents.
- Vacuums have motors and other parts that can produce sparks during normal use. Do not use within 30 feet of areas where explosive materials may be present (such as gasoline pumps and places where liquids like paint thinners, cleaners, solvents, etc. are stored).
- Do not use in the presence of explosive dust, liquids or vapors.
- Do not use where oxygen or anesthetics are used.
- Do not allow to be used as a toy. Close attention is necessary when used by or near children.
- Use extra care when using on stairs.

ELECTRICAL SAFETY

- Do not handle battery pack or vacuum with wet hands.

PERSONAL SAFETY

- STAY ALERT. Watch what you are doing and use common sense. Do not use vacuum when you are tired, distracted or under the influence of drugs, alcohol or medication causing diminished control.
- The operation of a vacuum can result in foreign objects being blown into eyes, which can result in eye damage. Always wear safety goggles or glasses with side shields when operating vacuum.
- Wear a dust mask or use an OSHA compliant vacuum solution when working in dusty situations. Dust particles can harm your lungs.
- Avoid accidental starting. Ensure the switch is in the off-position before inserting battery pack. Inserting battery pack in vacuum that has the switch on invites accidents.
- Do not overreach. Keep proper footing and balance at all times. This enables better control of the vacuum in unexpected situations.
- Keep hair, loose clothing, fingers, and all parts of body away from openings and moving parts.
- Use only as described in this manual. Use only manufacturer's recommended attachments.
- Prevent unintentional starting. Ensure the switch is in the off-position before connecting to power source and/or battery pack, picking up or carrying the tool. Carrying power tools with your finger on the switch or energizing power tools that have the switch on invites accidents.

VACUUM USE AND CARE

- Do not use without dust canister and/or filter in place.
- Do not use to pick up flammable or combustible liquids such as gasoline or use in areas where they may be present.
- Do not pick up anything that is burning or smoking such as cigarettes, matches, or hot ashes.

- Do not pick up soot, cement, plaster or drywall dust without filter in place. These are very fine particles that may affect the performance of the motor or be exhausted back into the air.
- This product is suitable for collection of silica dust when used in accordance with these instructions. To reduce the risk of health hazards from other vapors or dust, do not vacuum carcinogenic, toxic or hazardous materials such as asbestos, arsenic, barium, beryllium, lead, pesticides or other health endangered materials.
- Use special care when emptying heavily loaded tanks.
- To avoid spontaneous combustion, empty dust box after each use.
- Do not leave vacuum unattended when battery pack is installed. Remove battery pack when not in use and before servicing.
- Disconnect the battery pack from the appliance before making any adjustments, changing accessories, or storing appliance. Such preventive safety measures reduce the risk of starting the appliance accidentally.
- Do not put any object into openings. Do not use with any opening blocked; keep free of dust, lint, hair, and anything else that may reduce air flow.
- Maintain vacuum. Check for misalignment or binding of moving parts, breakage of parts and any other condition that may affect the vacuum's operation. If damaged, have the vacuum repaired before use. Many accidents are caused by poorly maintained tools.

BATTERY TOOL USE AND CARE

- Recharge only with the charger specified by the manufacturer. A charger that is suitable for one type of battery pack may create a risk of fire when used with another battery pack.
- Use power tools only with specifically designated battery packs. Use of any other battery packs may create a risk of injury and fire.
- When battery pack is not in use, keep it away from other metal objects, like paper clips, coins, keys, nails, screws or other small metal objects, that can make a connection from one terminal to another. Shorting the battery terminals together may cause burns or a fire.
- Under abusive conditions, liquid may be ejected from the battery; avoid contact. If contact accidentally occurs, flush with water. If liquid contacts eyes, additionally seek medical help. Liquid ejected from the battery may cause irritation or burns.
- Do not use a battery pack or tool that is damaged or modified. Damaged or modified batteries may exhibit unpredictable behavior resulting in fire, explosion or risk of injury.

- Do not expose a battery pack or tool to fire or excessive temperature. Exposure to fire or temperature above 265°F (130°C) may cause explosion.
- Follow all charging instructions and do not charge the battery pack or tool outside the temperature range specified in the instructions. Charging improperly or at temperatures outside the specified range may damage the battery and increase the risk of fire.

SERVICE

- Have your power tool serviced by a qualified repair person using only identical replacement parts. This will ensure that the safety of the power tool is maintained.
- Do not modify or attempt to repair the appliance or the battery pack (as applicable) except as indicated in the instructions for use and care.

SPECIFIC SAFETY RULES FOR WET/DRY VACUUM

- Never use vacuum without tank and filter properly installed.
- Wear ear protectors. Exposure to noise can cause hearing loss.
- This product is suitable for collection of silica dust when used in accordance with these instructions. To reduce the risk of health hazards from other vapors or dust, do not vacuum carcinogenic, toxic or hazardous materials such as asbestos, arsenic, barium, beryllium, lead, pesticides or other health endangered materials.

⚠WARNING To reduce the risk of injury, when working in dusty situations, wear appropriate respiratory protection or use an OSHA compliant dust extraction solution.

- Always use common sense and be cautious when using tools. It is not possible to anticipate every situation that could result in a dangerous outcome. Do not use this tool if you do not understand these operating instructions or you feel the work is beyond your capability; contact Milwaukee Tool or a trained professional for additional information or training.

- Maintain labels and nameplates. These carry important information. If unreadable or missing, contact a MILWAUKEE service facility for a free replacement.

⚠WARNING Some dust created by power sanding, sawing, grinding, drilling, and other construction activities contains chemicals known to cause cancer, birth defects or other reproductive harm. Some examples of these chemicals are:

- lead from lead-based paint
- crystalline silica from bricks and cement and other masonry products, and
- arsenic and chromium from chemically-treated lumber.

Your risk from these exposures varies, depending on how often you do this type of work. To reduce your exposure to these chemicals: work in a well ventilated area, and work with approved safety equipment, such as those dust masks that are specially designed to filter out microscopic particles.

READ AND SAVE ALL INSTRUCTIONS FOR FUTURE USE

FOR HOUSEHOLD OR COMMERCIAL USE.

SYMBOLOLOGY

-  Volts
-  Direct Current
-  Read Operator's Manual
-  Wear eye protection
-  Do Not Step
-  Max Power Mode
-  Off
-  Max Run-Time Mode
-  UL Listing for Canada and U.S.

SPECIFICATIONS

Cat. No.	0910-20, 0911-20
Volts.....	18 DC
Battery Type	M18™
Charger Type.....	M18™
Air Flow.....	87 CFM
Suction.....	60 in H2O
Capacity*	6 gal (23 L)
Recommended Ambient Operating Temperature.....	0°F to 104°F

* Gallons indicated reflect drum volume, not necessarily collection capacity, actual capacity dependent upon type of debris collected, condition of filter and other factors.
6 Gallon Wet/Dry Vacuum Tank included with 0910-20 only.

FUNCTIONAL DESCRIPTION

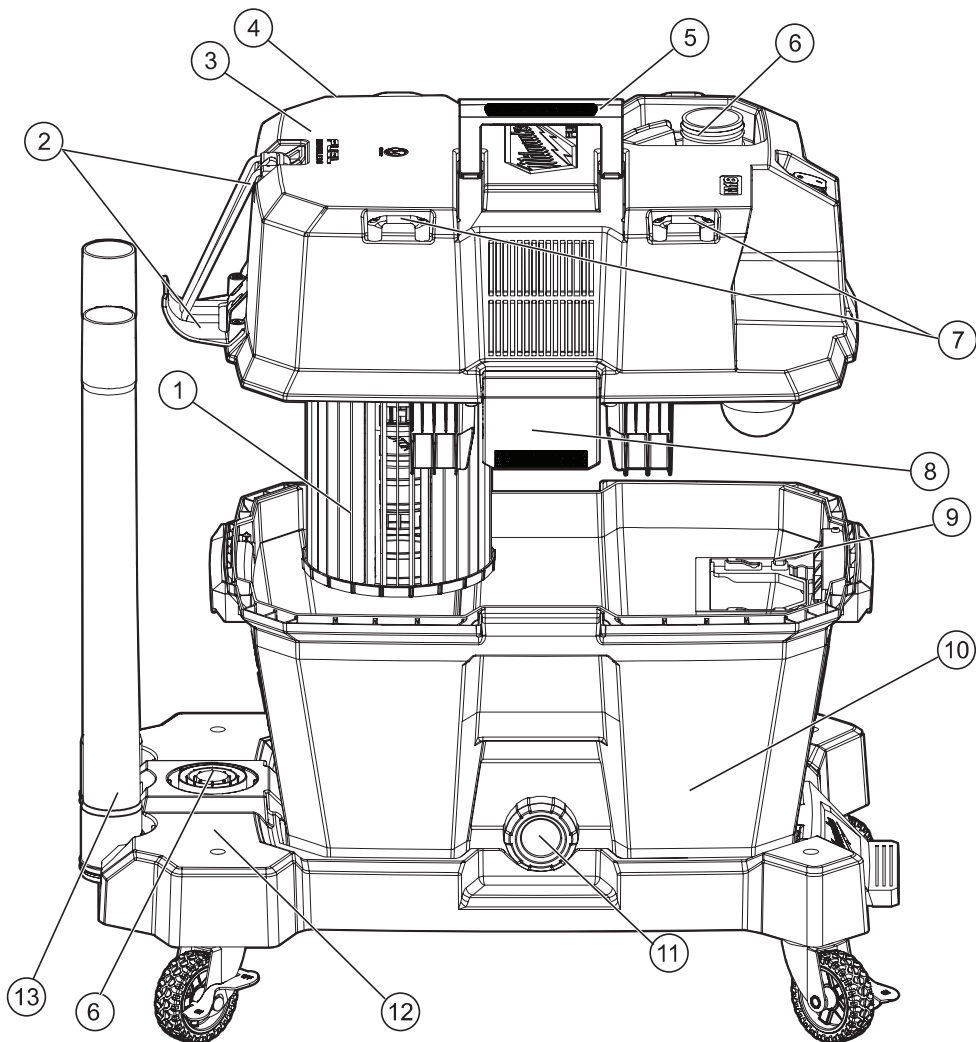

- | | |
|--|-----------------------------------|
| 1. High efficiency filter (included with 0910-20 only) | 10. 6 gallon wet/dry vacuum tank |
| 2. Hose storage | 11. Tank drain cap |
| 3. Motor housing | 12. Wet/dry vacuum cart (0923-20) |
| 4. Blower port (not shown) | 13. Extension wand |
| 5. Handle | 14. Battery bay |
| 6. Accessory storage areas | 15. Switch |
| 7. Storage tie downs | 16. Hose storage clip |
| 8. Tank latches (front and back) | 17. Vacuum inlet |
| 9. Dust bag holder | 18. Pedal |
| | 19. Wheel lock |

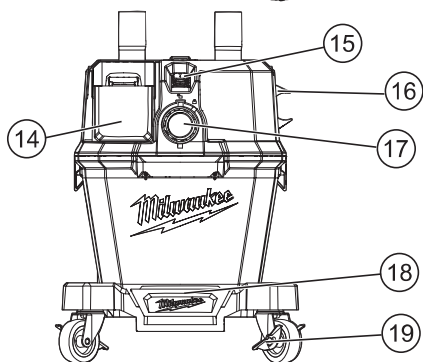

ASSEMBLY

⚠ WARNING To reduce the risk of injury, always remove the battery pack before removing the tank.

⚠ CAUTION Keep filter clean. Efficiency of the vacuum is largely dependent on the filter. A dirty filter will reduce the air flow and overall efficiency of the system. Remove from tank and tap clean.

⚠ WARNING Recharge only with the charger specified for the battery. For specific charging instructions, read the operator's manual supplied with your charger and battery.

Removing/Inserting the Battery

To **remove** the battery, push in the release buttons and pull the battery pack away from the tool.

⚠ WARNING Always remove the battery pack any time the tool is not in use.

To **insert** the battery, slide the pack into the body of the tool. Make sure it latches securely into place.

Removing/Installing the Filters

Use the high efficiency filter for dry pickup **only**. Use the foam filter for wet pick-up operation **only**.

1. Remove the battery pack.
2. Release the tank latches and lift off the motor housing. Place it upside down on a flat surface.
3. To **remove** the filter, turn it 1/2" counter clockwise and pull it off of the motor housing/float cage.
4. Empty all debris from the tank.

NOTICE When applicable, adhere to jobsite guidelines pertaining to the disposal of silica dust.

5. To **install** the filter, slide it over the float cage. Line up the filter tabs with the motor housing notches and turn it 1/2" clockwise to lock in place.
6. Replace the motor housing and secure both latches.

⚠ WARNING To reduce the risk of injury: wear safety glasses and a dust mask when using the vacuum cleaner as a blower. Clean tank completely before use.

Pick-Up/Blower

The vacuum can be used for debris pick-up or as a blower, depending on the port used.

1. For debris **pick-up**, insert the large end of the hose into the intake port of the motor housing, lining up the tabs on the hose with the notches in the port. Twist to secure and form a tight fit.

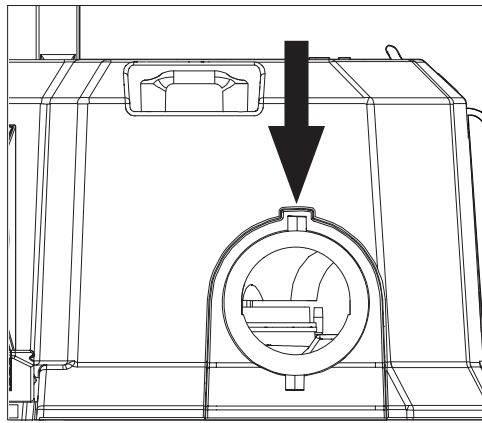

2. To use as a **blower**, insert the large end of hose into the blower port  of the motor housing, lining up the tabs on the hose with the notches in the port. Twist to secure and form a tight fit.

⚠ WARNING Only use accessories specifically recommended for this tool. Others may be hazardous.

Attaching/Removing the Wet/Dry Vacuum Cart

1. To **attach**, place rear of vacuum on the cart with the front angled upwards. The vacuum inlet should face the front of the cart where the pedal is located.
2. Slide the rear of the vacuum under the ledge feature.

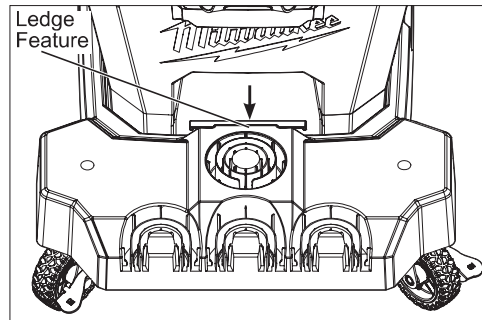

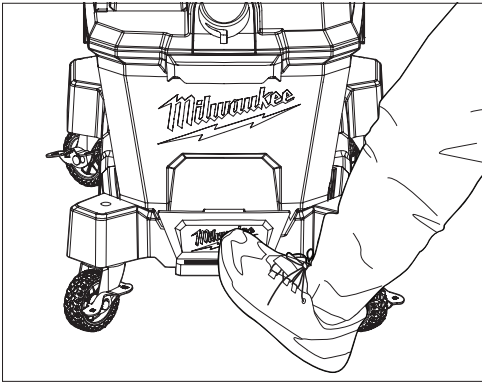

3. Lower the front of the vacuum so it lines up with the cart and front ledge. Once the cart clicks, the vacuum is secured on the cart.

- To **remove**, press one foot on the pedal. Lift the vacuum with handle away from the cart.



Installing/Removing the Hose

To **install** the hose, line up notches on the hose with the vacuum inlet. Push in and twist toward lock  to secure in place.

To **remove** the hose, twist the hose towards the unlock  and pull away from vacuum inlet.

Installing/Removing the Accessories

To **install** the nozzles, or extensions, push the accessory onto the vacuum hose until it feels secure. To **remove** the accessory, pull the accessory off the vacuum hose inlet. Store the accessories in the motor head or in the designated cart storage areas.

Installing/Removing the Dust Extraction Adapter

(Cat. No. 49-90-1980, not included)

The dust extractor hose adapter is used to connect the hose to a power tool in place of other dust collection, such as a dust bag.

To **install** the adapter, remove any nozzles or accessories from the end of the hose. Twist the adapter onto the hose until tight for a secure fit.

To **remove**, reverse the procedure.

Installing/Removing the Accessory Storage Bag

(Cat. No. 49-90-2019, not included)

- To **install**, ensure the top of the motor housing is clear.
- Place the accessory storage bag on top of the motor housing with the logo facing up.
- Locate the hooks on the accessory storage bag and attach them to the storage tie downs on the motor housing. **NOTE:** There are 2 storage tie downs on each side of motor housing with a total of 4 storage tie downs.

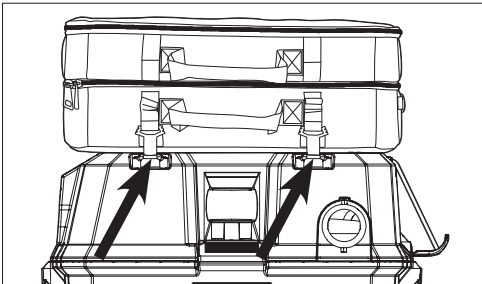

- To **remove**, unhook the accessory storage bag from the motor housing and remove the accessory storage bag.

OPERATION

⚠ WARNING To reduce the risk of injury, always wear proper eye protection marked to comply with ANSI Z87.1.

When working in dusty situations, wear appropriate respiratory protection or use an OSHA compliant dust extraction solution.

To reduce the risk of fire and injury, do not use to pick up flammable or combustible materials. Empty tank before use.

Before use, ensure the filter and float cage are properly installed. Remove dry filter before all wet pick-up operations.

Starting and Stopping Vacuum

To turn the vacuum On **max run-time mode**, push the switch to the Speed One (I) position.

To turn the vacuum On **max power mode**, push the switch to the Speed Two (II) position.

To turn **Off** the vacuum, push the switch to the OFF (O) position.

⚠ CAUTION If the float is clean, moves freely, and the suction does not shut off when the tank is filled, contact a MILWAUKEE service facility for repairs. A malfunctioning tool can cause personal injury or property damage.

Wet Pick-Up Operation

For wet pick-up operation, it is recommended to use the foam filter (Single pack, Cat. No. 49-90-1990).

- Remove the battery pack.
- Remove ALL dirt and debris found in the tank.
- Remove the high efficiency filter and install the foam filter (see "Removing/Installing the Filters"). Ensure that the float cage remains in place.

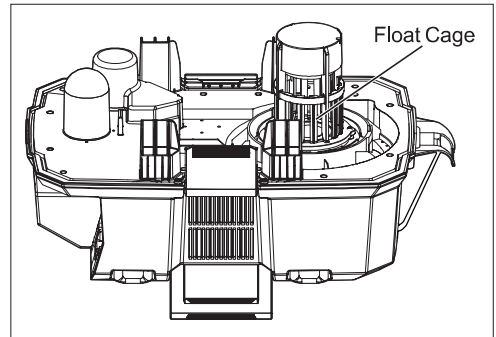

- A float cage shuts off suction when the tank is full. Be sure that the float is clean and moves freely in the float cage to ensure that the float valve works.
- Insert the battery pack.
- Turn on the vacuum and begin pick-up.
- Turn off the vacuum immediately upon completing a wet pick-up job or when tank is full and ready to be emptied. If suction shuts off, turn off the vacuum immediately and empty the tank.
- Remove the battery pack.

- To empty the tank, raise the hose to drain any excess liquid into the tank. Do not use vacuum inlet to drain contents.
- Remove motor housing and pour liquid waste into a suitable drain.
- Clean the interior of the tank and pick-up accessories periodically, more often when used to pick up wet, sticky materials. Use warm, soapy water. Do not store vacuum with liquid in tank.

Automatic Suction Shut-Off

When picking up liquids, an internal float rises until it seats itself against a seal at the intake of the motor, shutting off suction. When this happens, the motor will develop a higher than normal pitch noise and the suction is drastically reduced. If this occurs, turn off the vacuum immediately.

NOTICE Failure to turn off unit after float rises and shuts off suction will result in damage to the motor.

To continue use, empty the liquid waste from the tank. If the vacuum is accidentally tipped over, it could lose suction. Turn off the vacuum and return it to an upright position. The float will return to its normal position.

Installing/Removing Fleece Dust Bag

For increased filter life and ease of cleanup, use a fleece dust bag to collect fine dust particles (Single pack, Cat. No. 49-90-1979).

- To **install**, release the tank latches and remove the motor housing.
- Lift the dust bag holder up and out to remove from the tank.
- Slide the cardboard dust bag inlet in to the dust bag holder.

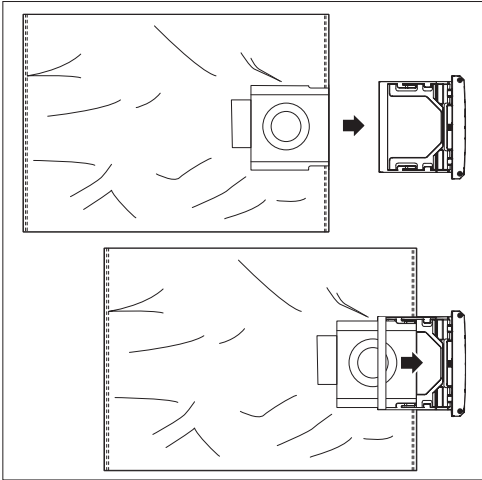

- Insert the dust bag holder back into the slot pushing downward to secure in place.
- Spread out the dust bag in the tank. Replace the motor housing and secure both latches.
- To **remove**, release the tank latches and remove motor housing.
- Lift the dust bag holder up and out to remove from the tank.
- Slide the dust bag holder off the dust bag.
- Pull the cardboard tab until the dust bag inlet is closed. Dust bag is now sealed and can be properly disposed.

Replace fleece dust bag once the bag is at full capacity, suction decreases or dust bag is damaged.

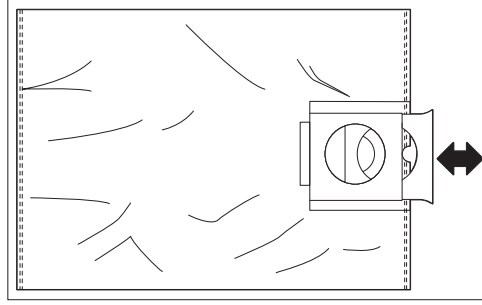

Storage

Before storing your vacuum, empty and clean the tank, filter, and accessories. Remove the battery pack.

MAINTENANCE

WARNING To reduce the risk of injury, always unplug the charger and remove the battery pack from the charger or tool before performing any maintenance. Never disassemble the tool, battery pack or charger. Contact a MILWAUKEE service facility for ALL repairs.

Never use vacuum without tank and filter properly installed.

Maintaining the Filters

Keep filter clean. Clean the filter by twisting the filter cover counter-clockwise to unlock from the motor housing/float cage. Pull the filter away from the vacuum. Empty debris by holding away from the user's face and tap clean. Water may be used to clean the filter.

If cleaning high efficiency filters with water, let filter dry 24 hours before using with vacuum. Replace filter if damaged or suction decreases (Dry filters single pack, Cat. No. 49-90-1977, 49-90-1978 or Wet filter single pack Cat. No. 49-90-1990).

Maintaining Tool

Keep your tool, battery pack and charger in good repair by adopting a regular maintenance program. Inspect your tool for issues such as undue noise, misalignment or binding of moving parts, breakage of parts, or any other condition that may affect the tool operation. Return the tool, battery pack, and charger to a MILWAUKEE service facility for repair. After six months to one year, depending on use, return the tool, battery pack and charger to a MILWAUKEE service facility for inspection.

If the tool does not start or operate at full power with a fully charged battery pack, clean the contacts on the battery pack. If the tool still does not work properly, return the tool, charger and battery pack, to a MILWAUKEE service facility for repairs.

⚠ WARNING To reduce the risk of personal injury and damage, never immerse your tool, battery pack or charger in liquid or allow a liquid to flow inside them.

Cleaning

Clean dust and debris from any vents. Keep tool clean, dry and free of oil or grease. Use only mild soap and a damp cloth to clean, since certain cleaning agents and solvents are harmful to plastics and other insulated parts. Some of these include gasoline, turpentine, lacquer thinner, paint thinner, chlorinated cleaning solvents, ammonia and household detergents containing ammonia. Never use flammable or combustible solvents around tools.

Repairs

For repairs, return the tool, battery pack and charger to the nearest authorized service center.

ACCESSORIES

⚠ WARNING Use only recommended accessories. Others may be hazardous.

For a complete listing of accessories, go online to www.milwaukeetool.com or contact a distributor.

Compatible with 0910-20 Wet/Dry Vacuum	
0912-20	9 Gallon Wet/Dry Vacuum Tank
0932-20	12 Gallon Wet/Dry Vacuum Tank
0931-20	6.5 Peak HP Wet/Dry Vacuum Motor Head
0921-20	M18 FUEL™ Wet/Dry Vacuum Dual Battery Motor Head
0933-20	Premium Wet/Dry Vacuum Cart
49-90-1980	Dust Extraction Adapter

SERVICE - UNITED STATES

1-800-SAWDUST (1.800.729.3878)
Monday-Friday, 7:00 AM - 6:30 PM CST
or visit www.milwaukeetool.com

Contact Corporate After Sales Service Technical Support with technical, service/repair, or warranty questions.

Email: metproductsupport@milwaukeetool.com

Become a Heavy Duty Club Member at www.milwaukeetool.com to receive important notifications regarding your tool purchases.

SERVICE - CANADA

Milwaukee Tool (Canada) Ltd
1.800.948.2360
Monday-Friday, 7:00 AM - 4:30 PM CST
or visit www.milwaukeetool.ca

LIMITED WARRANTY USA & CANADA

This MILWAUKEE power tool¹ is warranted to the original purchaser from an authorized MILWAUKEE distributor only to be free from defects in material and workmanship. Subject to certain exceptions, MILWAUKEE will repair or replace any part on this power tool which, after examination, is determined by MILWAUKEE to be defective in material or workmanship for a period of five (5) years after the date of purchase unless otherwise noted. Return of the power tool to a MILWAUKEE factory Service Center location or MILWAUKEE Authorized Service Station, freight prepaid and insured, is required. A copy of the proof of purchase should be included with the return product. This warranty does not apply to damage that MILWAUKEE determines to be from repairs made or attempted by anyone other than MILWAUKEE authorized personnel, misuse, alterations, abuse, normal wear and tear, lack of maintenance, or accidents.

Normal Wear: Many power tools need periodic parts replacement and service to achieve best performance. This warranty does not cover repair when normal use has exhausted the life of a part including, but not limited to, chucks, brushes, cords, saw shoes, blade clamps, o-rings, seals, bumpers, driver blades, pistons, strikers, lifters, and bumper cover washers.

¹This warranty does not cover battery packs or all power tools. Refer to the separate and distinct warranties available for those products. The warranty period for the LED in the LED Work Light (49-24-0171) and the LED Upgrade Bulb (49-81-0090) is the lifetime of the product subject to the limitations above. If during normal use the LED or LED Upgrade Bulb fails, the part will be replaced free of charge.

Warranty Registration is not necessary to obtain the applicable warranty on a MILWAUKEE power tool product. The manufacturing date of the product will be used to determine the warranty period if no proof of purchase is provided at the time warranty service is requested.

ACCEPTANCE OF THE EXCLUSIVE REPAIR AND REPLACEMENT REMEDIES DESCRIBED HEREIN IS A CONDITION OF THE CONTRACT FOR THE PURCHASE OF EVERY MILWAUKEE PRODUCT. IF YOU DO NOT AGREE TO THIS CONDITION, YOU SHOULD NOT PURCHASE THE PRODUCT. IN NO EVENT SHALL MILWAUKEE BE LIABLE FOR ANY INCIDENTAL, SPECIAL, CONSEQUENTIAL, OR PUNITIVE DAMAGES, OR FOR ANY COSTS, ATTORNEY FEES, EXPENSES, LOSSES OR DELAYS ALLEGED TO BE AS A CONSEQUENCE OF ANY DAMAGE TO, FAILURE OF, OR DEFECT IN ANY PRODUCT INCLUDING, BUT NOT LIMITED TO, ANY CLAIMS FOR LOSS OF PROFITS. SOME STATES DO NOT ALLOW THE EXCLUSION OR LIMITATION OF INCIDENTAL OR CONSEQUENTIAL DAMAGES, SO THE ABOVE LIMITATION OR EXCLUSION MAY NOT APPLY TO YOU. THIS WARRANTY IS EXCLUSIVE AND IN LIEU OF ALL OTHER EXPRESS WARRANTIES, WRITTEN OR ORAL, TO THE EXTENT PERMITTED BY LAW, MILWAUKEE DISCLAIMS ANY IMPLIED WARRANTIES, INCLUDING WITHOUT LIMITATION ANY IMPLIED WARRANTY OF MERCHANTABILITY OR FITNESS FOR A PARTICULAR USE OR PURPOSE. TO THE EXTENT SUCH DISCLAIMER IS NOT PERMITTED BY LAW, SUCH IMPLIED WARRANTIES ARE LIMITED TO THE DURATION OF THE APPLICABLE EXPRESS WARRANTY AS DESCRIBED ABOVE. SOME STATES DO NOT ALLOW LIMITATIONS ON HOW LONG AN IMPLIED WARRANTY LASTS, SO THE ABOVE LIMITATION MAY NOT APPLY TO YOU. THIS WARRANTY GIVES YOU SPECIFIC LEGAL RIGHTS, AND YOU MAY ALSO HAVE OTHER RIGHTS WHICH VARY FROM STATE TO STATE.

This warranty applies to product sold in the U.S.A. and Canada only. Please consult the 'Service Center Search' in the Parts & Service section of MILWAUKEE's website www.milwaukeetool.com or call 1.800.SAWDUST (1.800.729.3878) to locate your nearest service facility for warranty and non-warranty service on a MILWAUKEE power tool.