

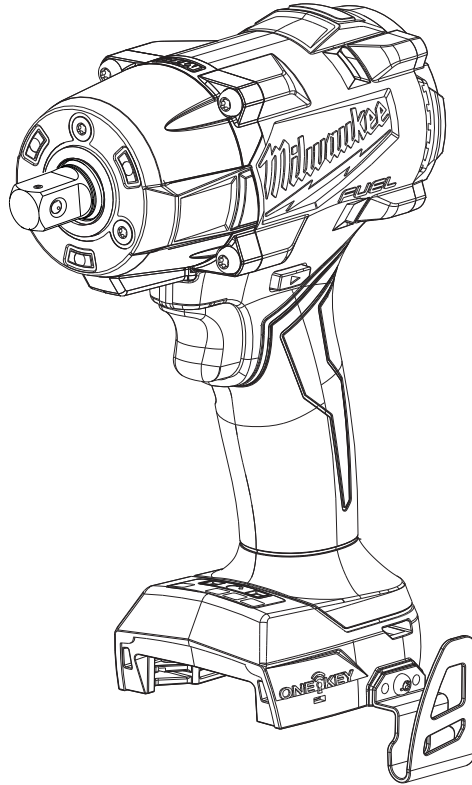

SERVICE PARTS LIST

BULLETIN NO.
54-26-3055

SPECIFY CATALOG NO. AND SERIAL NO. WHEN ORDERING PARTS				REVISED BULLETIN	DATE
M18 FUEL™ 1/2" Pin Detent Controlled Mid-Torque Impact Wrench					Sept. 2023
CATALOG NO.	3062P-20	SERIAL NO.	N63A	WIRING INSTRUCTION See Page 4	



This product is to be serviced **ONLY** by personnel authorized by MILWAUKEE TOOL. Do **NOT** attempt to purchase parts and install them yourself. Installation by anyone other than an authorized MILWAUKEE personnel could void your warranty.

For service, parts, or inquiries, contact us:

- Customer Service at 1.800.SAWDUST (1.800.729.3878)
- E-Service tool repair at: www.milwaukeetool.com/e-service
- Find a local approved MILWAUKEE service location at Milwaukeetool.com
- Find a MILWAUKEE *factory* Service Center Location or MILWAUKEE *factory* Central Repair Center at Milwaukeetool.com. Send the following, posted paid and insured:
 - Your name, address, and phone number
 - Description of the issues
 - Copy of the proof of purchase
 - Tool, charger, and batteries involved with the issues

MILWAUKEE *factory* Central Repair Centers:

MILWAUKEE TOOL
Central Repair
1401 Sycamore Avenue
Greenwood, MS 38930

MILWAUKEE TOOL
Central Repair
2198 Southtech Drive
Greenwood, IN 46143

SERVICE PARTS EXPLODED VIEW

EXAMPLE:
 00 0 Component Parts (Small #)
 Are Included When Ordering
 The Assembly (Large #).

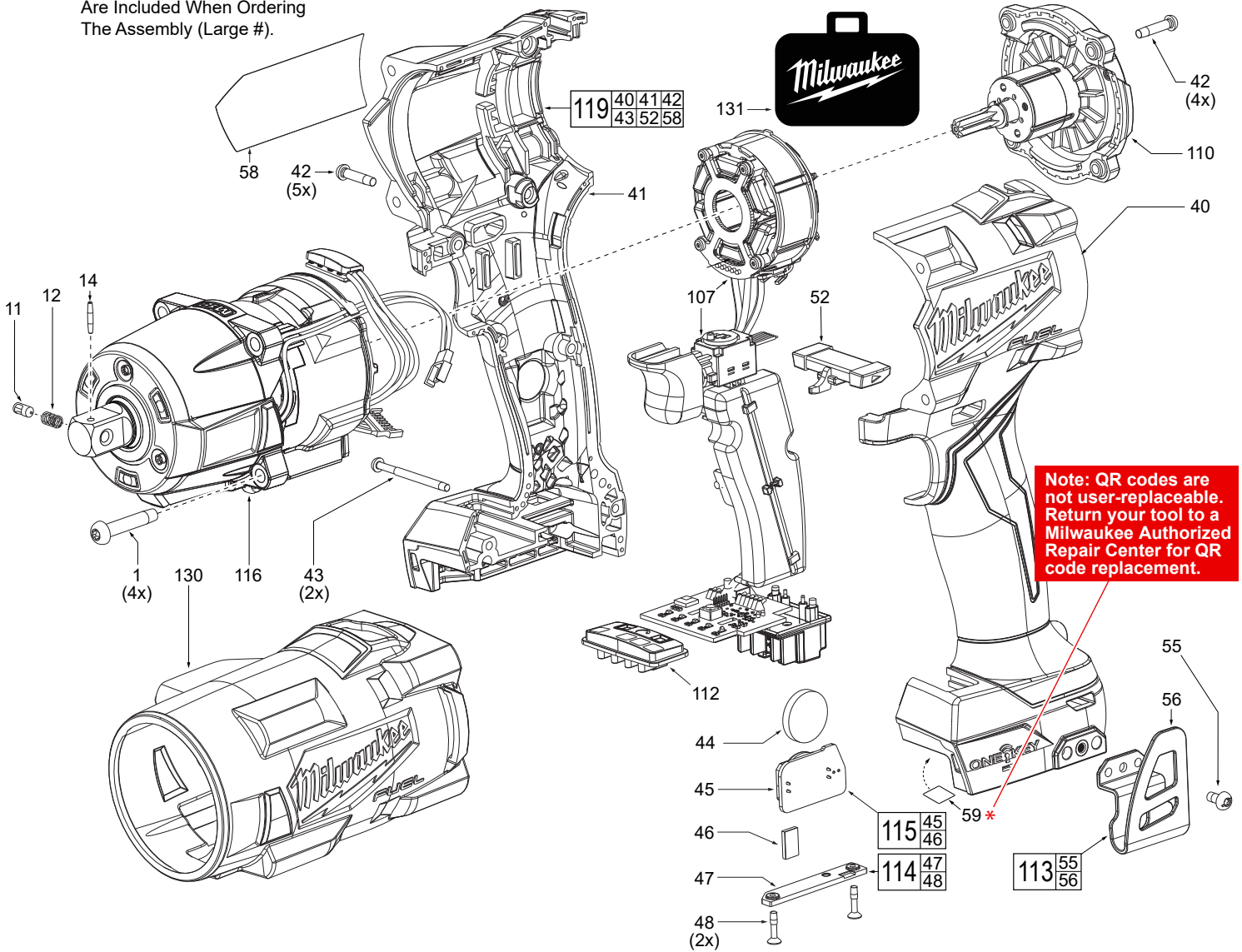

FIG.	PART NO.	DESCRIPTION OF PART	NO. REQ.
1	06-82-2366	Gearcase Screw	(4)
11	44-60-7085	Detent Pin	(1)
12	40-50-4051	Anvil Spring	(1)
14	44-60-0022	Solid Pin	(1)
40	-----	Right Housing Halve-Cover	(1)
41	-----	Left Housing Halve-Support	(1)
42	06-82-2368	M3 x 1.058 Pan Hd. ST T-10 Screw	(9)
43	06-82-2367	M3 x 1.058 Pan Hd. ST T-10 Screw	(2)
44	-----	Coin Cell Battery	(1)
45	-----	Coin Cell PCBA	(1)
46	-----	Foam Pad	(1)
47	-----	Coin Cell Cover	(1)
48	-----	M2.6 PH ST Screw	(2)
52	45-24-8200	Forward/Reverse Shuttle	(1)
55	06-82-2500	6-32 x 7mm Pan Hd. Tapt. T-15 Screw	(1)
56	42-70-5151	Belt Clip	(1)
58	12-20-9915	Service Nameplate	(1)
59	-----	QR Code Label	(1)
109	14-20-9390	Electronics Assembly	(1)
110	16-01-6030	Rotor/Back Cap Assembly	(1)
112	45-24-2860	Speed Selector Assembly	(1)

FIG.	PART NO.	DESCRIPTION OF PART	NO. REQ.
113	42-70-0950	Belt Clip Kit	(1)
114	45-04-7015	Cell Cover Screw Assembly	(1)
115	22-09-0015	Coin Cell PCBA Assembly	(1)
116	14-30-6320	Gearbox Assembly	(1)
119	31-44-7045	Handle Housing Kit	(1)
130	49-16-3062	Rubber Boot (Accessory)	(1)
131	48-53-3062	Blow Molded Carrying Case	(1)

SCREW TORQUE SPECIFICATIONS				
FIG.	PART NO.	WHERE USED	SEAT TORQUE	
			(kgf-cm)	(lbs-in)
1	06-82-2366	Gearcase Assy.	38±3	33±3
42	06-82-2368	Right Housing Halve	11±1	10±1
42	06-82-2368	Rotor/Back Cap Assy.	9±1	8±1
43	06-82-2367	Right Housing Halve	11±1	10±1
48	-----	Cell Cover Screw Assy.	4±1	3±1
55	42-70-5151	Belt Clip	4±1	3±1

LUBRICATION INSTRUCTIONS

Use Type "J" Grease, No. 49-08-4220 (1-lb. tub)

NOTE: When servicing, clean the rotor surface with a dry cloth.

Regarding parts to be lubricated:

- ① Apply a light coating of grease to these parts.
- ② Apply a liberal amount of grease to these parts.

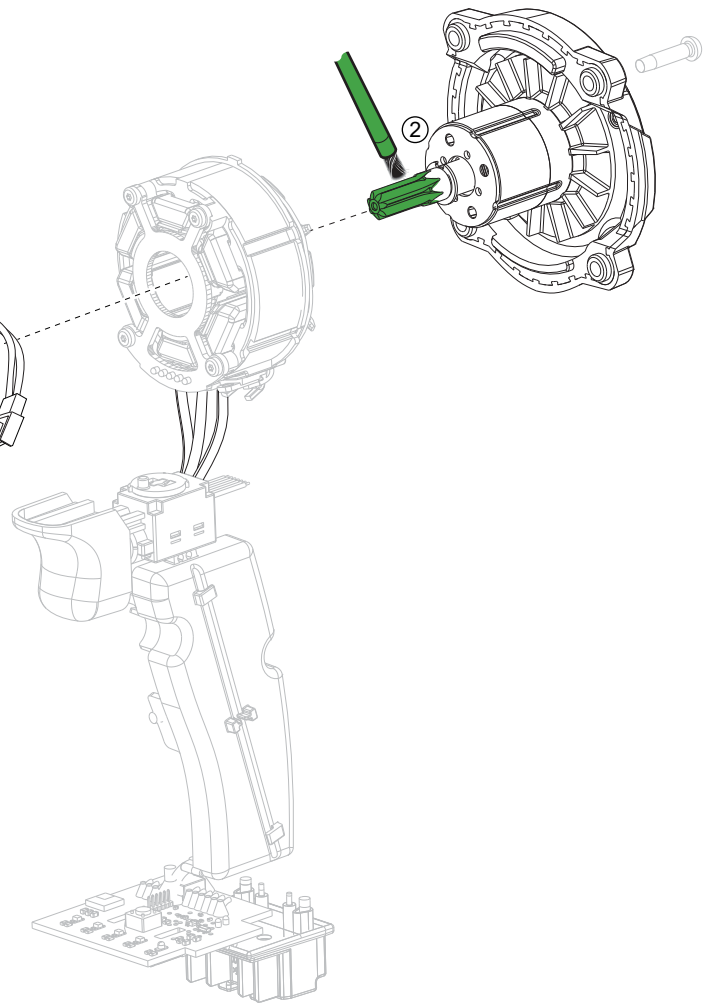
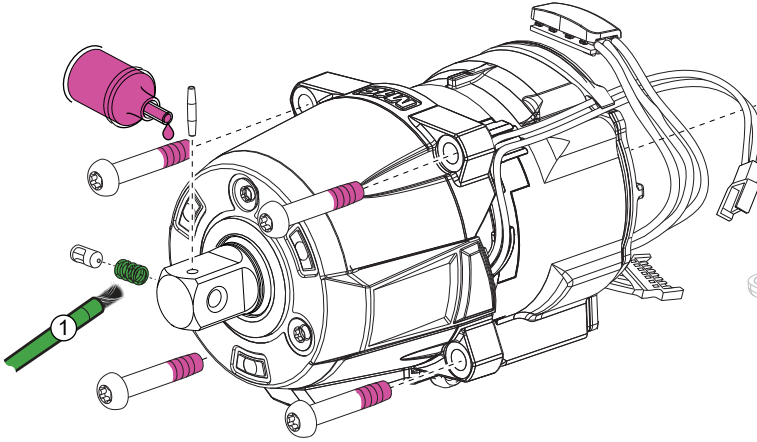

Use Red Loctite 277, No. 44-22-0050

NOTE: Regarding parts to receive thread locking sealant: Place **3-4 drops per screw** of the recommended Loctite® thread locking sealant (or the equivalent) to the threads of parts shown prior to installation.

WIRE ROUTING

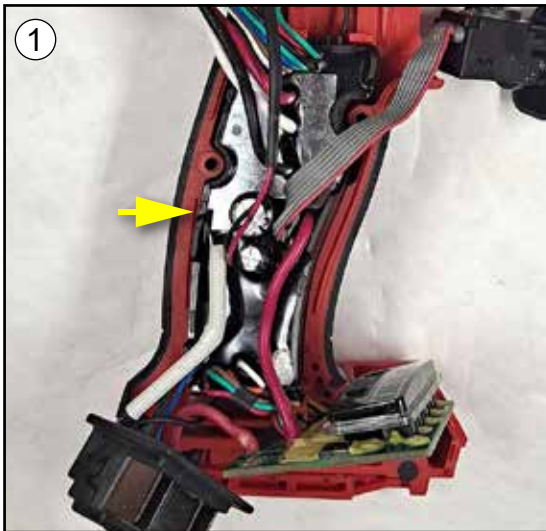

Place PCBA assembly in left handle half.

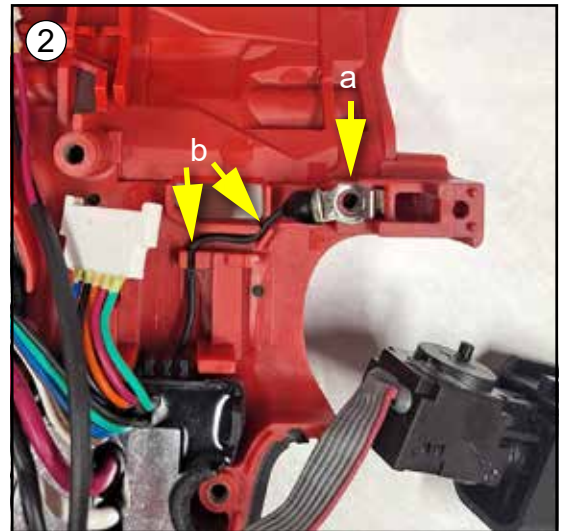

Place high voltage ring terminal over the screw boss as shown (a). Route ground wire (b) through the traps/channels in handle half.

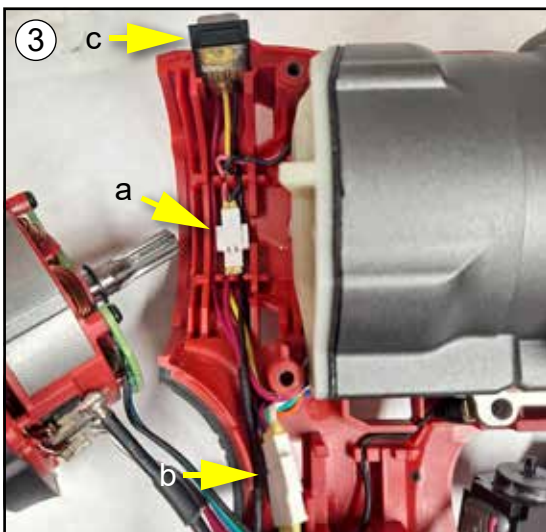

Connect the shadowless LED connector (a) and indicator connector (b). Place indicator (c) in groove. Route wires as shown, placing wires and connector firmly down in traps.

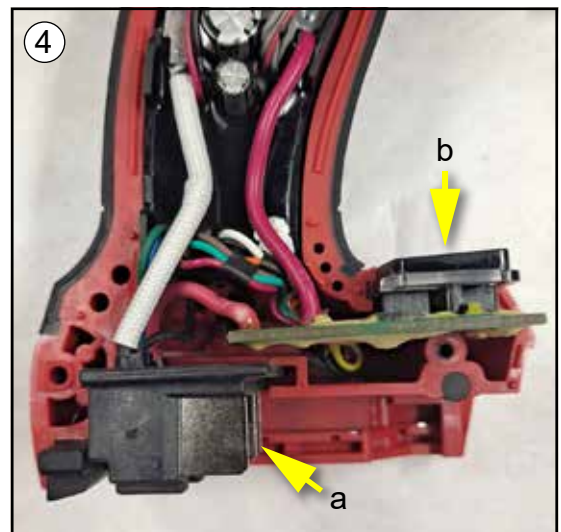

Assemble the battery terminal block (a) and mode selector board (b) into the corresponding cavities in housing support.

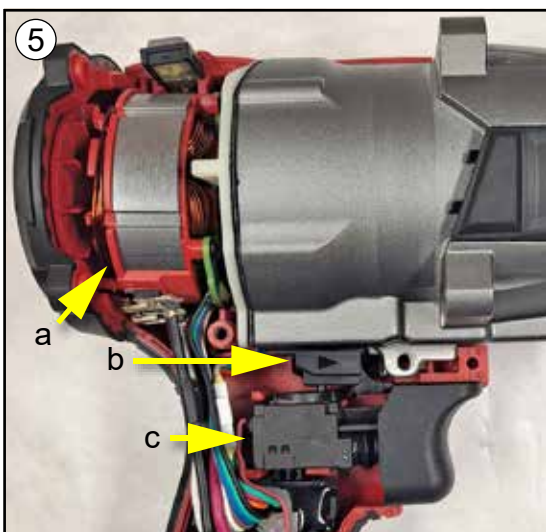

Install stator (a) firmly and squarely in handle cavity. Install the shuttle (b) and on-off switch (c) over the ground wire and into cavity in handle half, firmly and squarely in position. Check that all electrical and mechanical components are properly in place, with no interferences creating pinched wires.



Install right handle half (cover) over left handle half (support). Check for the proper functionality of switch and shuttle. Secure handle halves together with seven screws.