



# SERVICE PARTS LIST

**BULLETIN NO.**  
**54-49-0025**

SPECIFY CATALOG NO. AND SERIAL NO. WHEN ORDERING PARTS				REVISED BULLETIN	DATE
<b>CUT-OFF SAW CART</b>					Oct. 2019
<b>CATALOG NO.</b>	<b>3100</b>	<b>STARTING SERIAL NO.</b>	<b>K44A</b>	WIRING INSTRUCTION	

**EXAMPLE:**  

00	0
----	---

 Component Parts (Small #) Are Included  
 When Ordering The Assembly (Large #).

FIG.	PART NO.	DESCRIPTION OF PART	NO. REQ.
1	-----	Base Assembly	(1)
1f	05-88-0026	M6 Hex Nut with Nylok	(2)
2	06-82-9625	M8 x 20mm Cap Hd. Hex Socket Bolt	(3)
3	45-88-8945	Washer	(3)
4	-----	Wheel	(3)
5	06-82-9626	M6 x 14mm Pan Hd T-30 Machine Screw	(2)
6	45-88-8940	Washer	(2)
7	45-12-0046	Rubber Shield	(1)
8	45-76-0561	End Cap	(4)
9	45-76-0562	End Cap	(1)
10	42-32-0095	M6 x 40mm Hex Hd. Bolt	(1)
11	65-31-1055	Rubber for Battery	(1)
12	65-31-1060	Battery Interface	(1)
13	06-82-9627	M6 x 17mm Flat Hd. Hex Recess Mach. Scr.	(2)
14	45-88-8950	Washer	(5)
15	-----	Linkage	(1)
16	51-05-0165	M8 Hex Flange Nut	(1)
17	45-88-8951	Washer	(2)
18	44-90-5275	C Retaining Ring	(1)
20	-----	Front Arm Assembly	(1)
21	45-76-0563	End Cap	(1)
22	42-32-0097	M10 Hex Head Shoulder Bolt	(1)
27	43-98-5325	Latch Adjustment Knob	(1)
28	06-82-1080	M3 x 14mm Pan Hd. ST T-10 Screw	(6)
29	-----	Position Plate Housing-Right	(1)
30	42-32-0096	M16 x 62mm Hex Hd. Hollow Bolt	(1)
31	-----	Notch Tooth Disc	(1)
46	14-34-6010	C Handle Assembly	(1)
47	06-82-0136	M6 x 14mm Pan Hd. Taptite T-30 Screw	(3)
48	42-70-0011	Brake Wire Clip	(3)
49	-----	Lever Housing Rubber	(1)
50	-----	Drive Lever Housing Cover	(1)
51	05-88-1275	M4 x 70mm Pan Hd. ST Phillips Screw	(4)
52	-----	Drive Lever Housing Support	(1)
53	40-50-7815	Tension Spring	(1)
54	23-50-0035	Spacer	(1)
56	42-32-0099	M10 x 46mm CH Hex Recess Shoulder Bolt	(1)
65	42-42-2720	Throttle Button	(1)
66	05-88-0030	M3 x 8.5mm ST T-10 Washer Hd. Screw	(1)
67	23-56-0030	Slider Actuator	(1)
68	40-50-7021	Spring	(1)
69	14-34-0018	Lever Handle Assembly	(1)
70	31-12-8978	End Cap	(1)
71	42-32-0100	M10 x 65mm Hex Head Bolt	(2)
72	43-74-0285	Backup Water Tank Hook-Upper	(1)
73	05-88-0029	M10 Hex Nut	(8)
74	-----	Backup Water Tank Holder Assembly	(1)
75	43-74-0290	Backup Water Tank Hook-Lower	(1)
76	42-32-0098	M10 x 25mm Carriage Bolt	(4)
77	-----	Water Tank Holder Assembly	(1)
85	-----	Hook	(2)
86	06-82-9629	M10 x 26mm Hex Hd. Bolt	(2)
87	-----	Water Tank Assembly	(1)
93	44-90-5285	C Retaining Ring	(1)
94	44-10-0830	Latch Knob	(1)
95	42-32-0101	M8 Hex Head Shoulder Bolt	(1)
96	45-88-8953	Washer	(1)
97	44-10-0835	Trigger Paddle	(1)
98	-----	Hose Clip	(1)
99	-----	Water Hose	(1)
100	42-86-0023	Quick Connector	(1)
101	14-38-2015	Position Housing Assembly	(1)
102	05-81-0136	M4 x 12mm Flat Hd. Phillips Screw	(1)
103	14-04-0115	Brake Wire Service Kit	(1)
107	42-92-0078	Wheel Assembly Service Kit	(3)

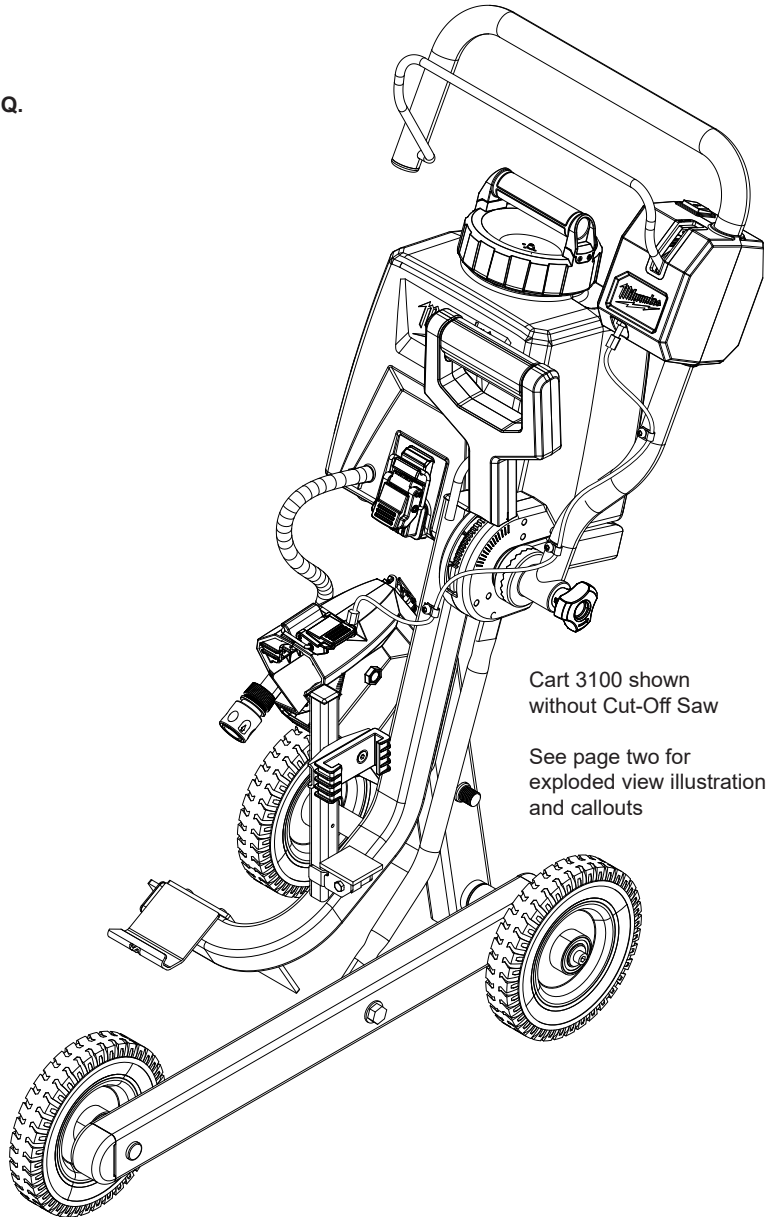

Cart 3100 shown  
without Cut-Off Saw

See page two for  
exploded view illustration  
and callouts

FIG.	PART NO.	DESCRIPTION OF PART	NO. REQ.
109	28-50-6356	Start Lever Service Assembly	(1)
111	42-36-1635	Tank Bracket 1 Service Kit	(1)
112	44-60-5375	Tank Cap Service Kit	(1)
114	42-36-1645	Tank Bracket 2 Service Kit	(1)
115	14-34-0019	Saw Handle Attachment Service Assembly	(1)
116	32-05-3334	Linkage Service Kit	(1)
117	42-09-0035	Front Arm Assembly Service Kit	(1)
118	28-50-6355	Lever Housing Service Kit	(1)
120	44-20-1070	Latch Service Kit	(2)
121	14-34-0023	D-Handle Service Assembly	(1)
122	42-86-0045	Hose and Quick Connector Assembly	(1)
123	42-36-1634	Water Tank Service Assembly	(1)
	12-20-0183	Service Nameplate (Not Shown)	(1)

