



SERVICE PARTS LIST

BULLETIN NO.
54-00-3700

SPECIFY CATALOG NO. AND SERIAL NO. WHEN ORDERING PARTS		REVISED BULLETIN	DATE
M18™ RED Exterior Rotary LASER LEVEL			July 2023
CATALOG NO.	3701-20	WIRING INSTRUCTION	
SERIAL NO.	M95A		

EXAMPLE:
Component Parts (Small #)
Are Included When Ordering
The Assembly (Large #).

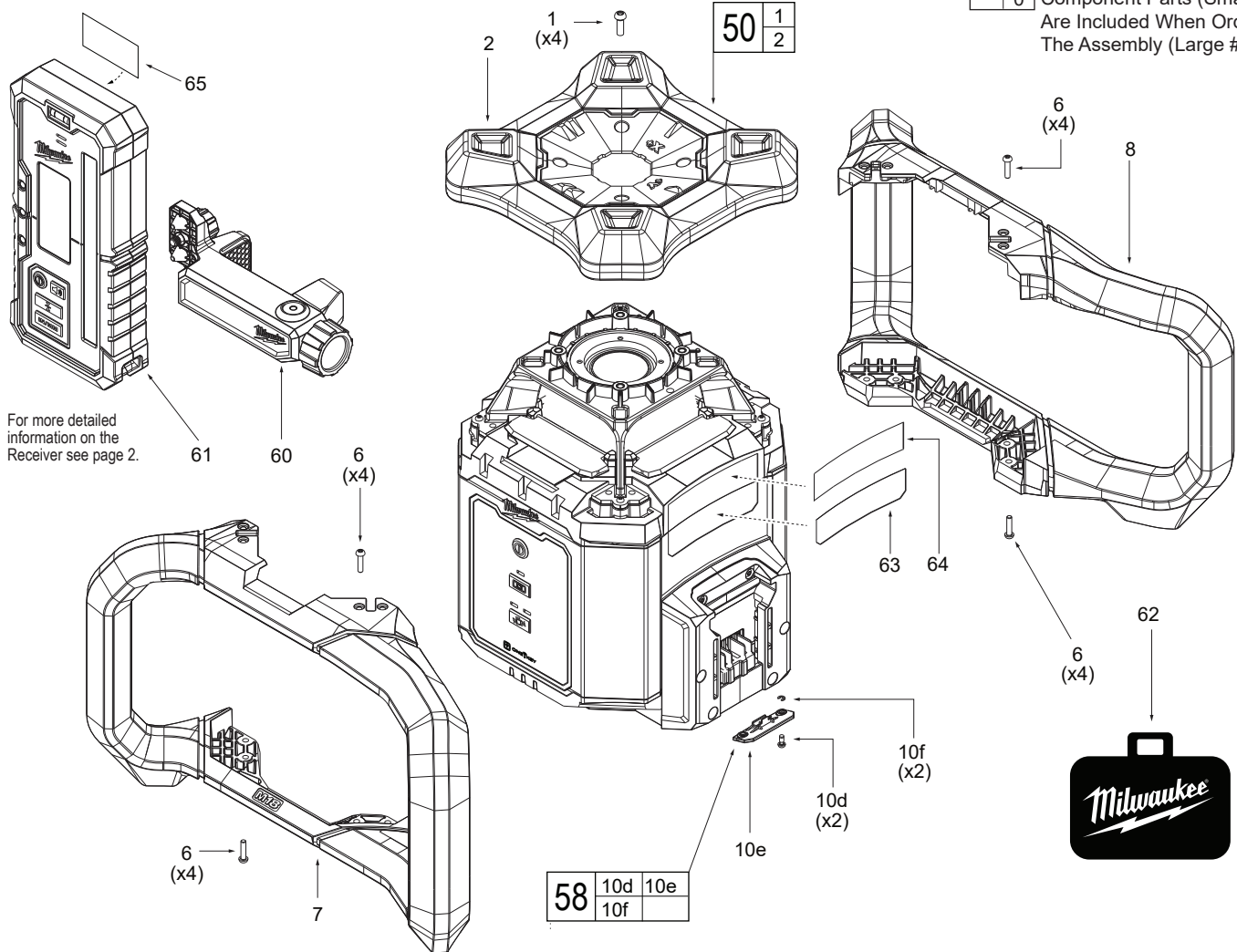

FIG.	PART NO.	DESCRIPTION OF PART	NO. REQ.
1	05-74-0747	M4 x 10mm Pan Hd. Torx T-20 Screw	(4)
2	42-38-0038	Top Bumper / Rotary Laser	(1)
6	05-74-0748	M3 x 12mm PH Torx T-10 M Screw	(38)
7	31-44-0611	Rotary Handle A-Side	(1)
8	31-44-0613	Rotary Handle B-Side	(1)
10d	05-74-0758	M2.6 x 6mm T8 ST Screw with Slot	(2)
10e	-----	Coin Cell Cover	(1)
10f	42-70-0041	E-Clip / ID=1.9mm	(2)
50	42-38-0037	Top Bumper Kit / Rotary Laser	(1)
58	31-15-0226	Coin Cell Cover Assembly	(1)
60	22-38-0106	Rotary Detector Clamp Assembly	(1)
61	3711	Red Rotary Laser Receiver Assembly	(1)
62	42-55-0127	BMC - Blow Molded Case	(1)
63	12-20-0305	Service Nameplate - Laser	(1)
64	10-20-7214	Warning Label - Laser	(1)
65	12-20-0306	Service Nameplate - Receiver	(1)

SCREW TORQUE SPECIFICATIONS				
FIG.	PART NO.	WHERE USED	SEAT TORQUE	
			(kgf-cm)	(lb-in)
10d	05-74-0758	Coincell Cover	5.0 ± 0.5	4.3 ± 0.4

Service needs pertaining to accuracy or calibration can only be performed at MILWAUKEE TOOL Central Repair:
1401 Sycamore Ave., Greenwood, MS 38930-7277 OR
2198 Southtech Drive, Greenwood, IN 46143-6725

OR Via e-Service at: www.milwaukeetool.com/e-service.

QUESTIONS: please call 1.800.SAWDUST OR
Return it to a MILWAUKEE FACTORY SERVICE CENTER location,
freight prepaid and insured. A copy of the proof of purchase should
be included with the return product.

FIG. NOTES
63, 64, 65 A clean, dry surface is essential for proper performance for any adhesive system. The area intended for application of any adhesive label or nameplate must be prepared by cleaning with isopropyl and alcohol. The solvent is to be applied with a clean, lint free applicator the surface allowed to dry before applying the label or name plate.

EXTERIOR ROTARY LASER - RECEIVER

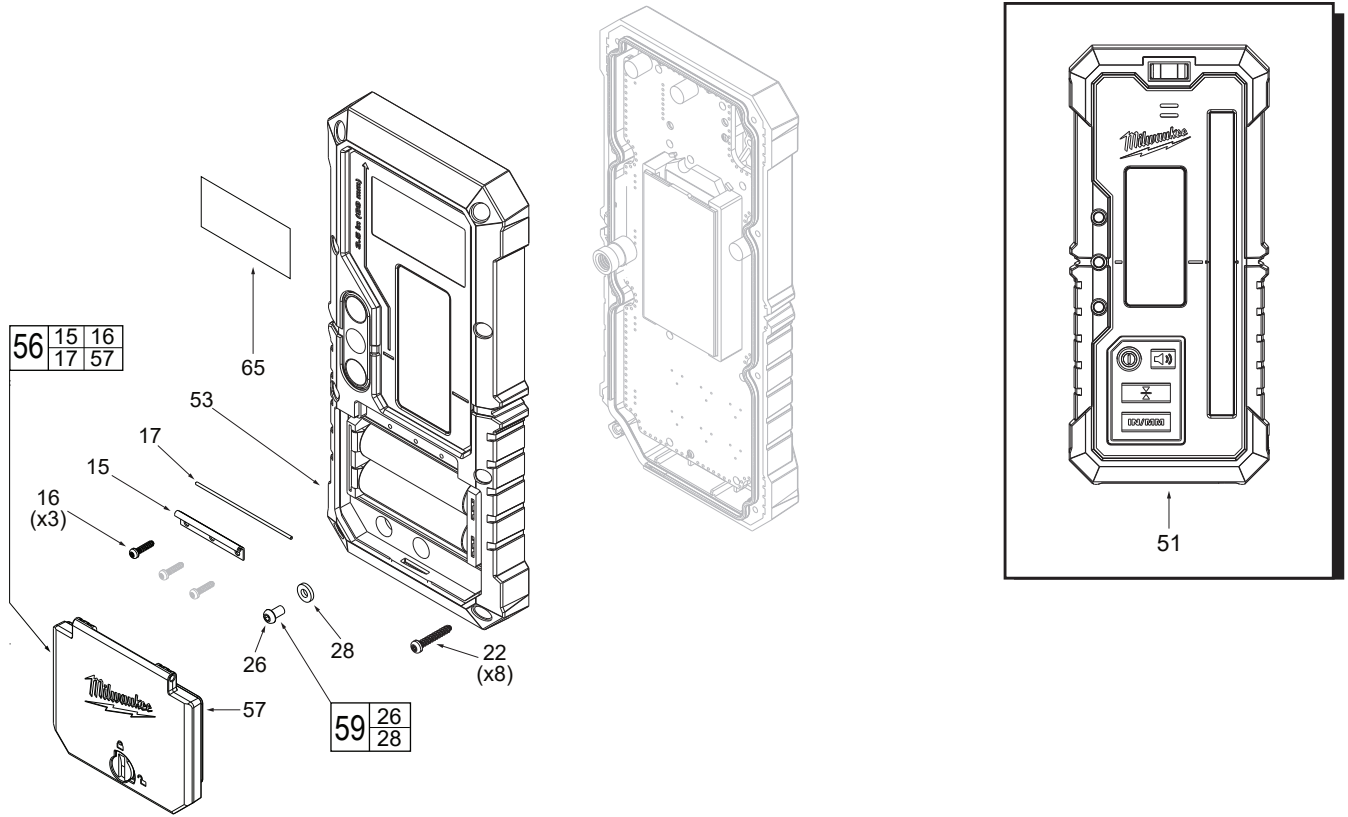

FIG.	PART NO.	DESCRIPTION OF PART	NO. REQ.
15	31-21-0048	Power Cell Door Hinge	(1)
16	05-74-0754	M2 x 8mm Pan Head T6 ST Screw	(3)
17	31-21-0049	Power Cell Door Pin	(1)
22	05-74-0756	M2.5 x 15mm Pan Head T8 Screw	(8)
26	05-74-0761	M3x5mm PH H2 Leak Test Screw	(1)
28	43-44-0613	Leak Test Gasket/ ID=3mm T=1.2mm	(1)
51	3711	Red Exterior Rotary Laser Detector	(1)
53	31-50-0201	Bottom Housing Assembly/Detector	(1)
56	31-21-0051	Power Cell Door Kit/Detector	(1)
57	31-21-0052	Power Cell Door Assembly/Detector	(1)
59	43-44-0612	Leak Test Gasket Kit	(1)
65	12-20-0306	Service Nameplate	(1)