



PIPE TOOLS & VISES  
SINCE 1896

# 5401TMSO Threading Machines

Replacement Parts

## Parts Manual for 120V and 240V models

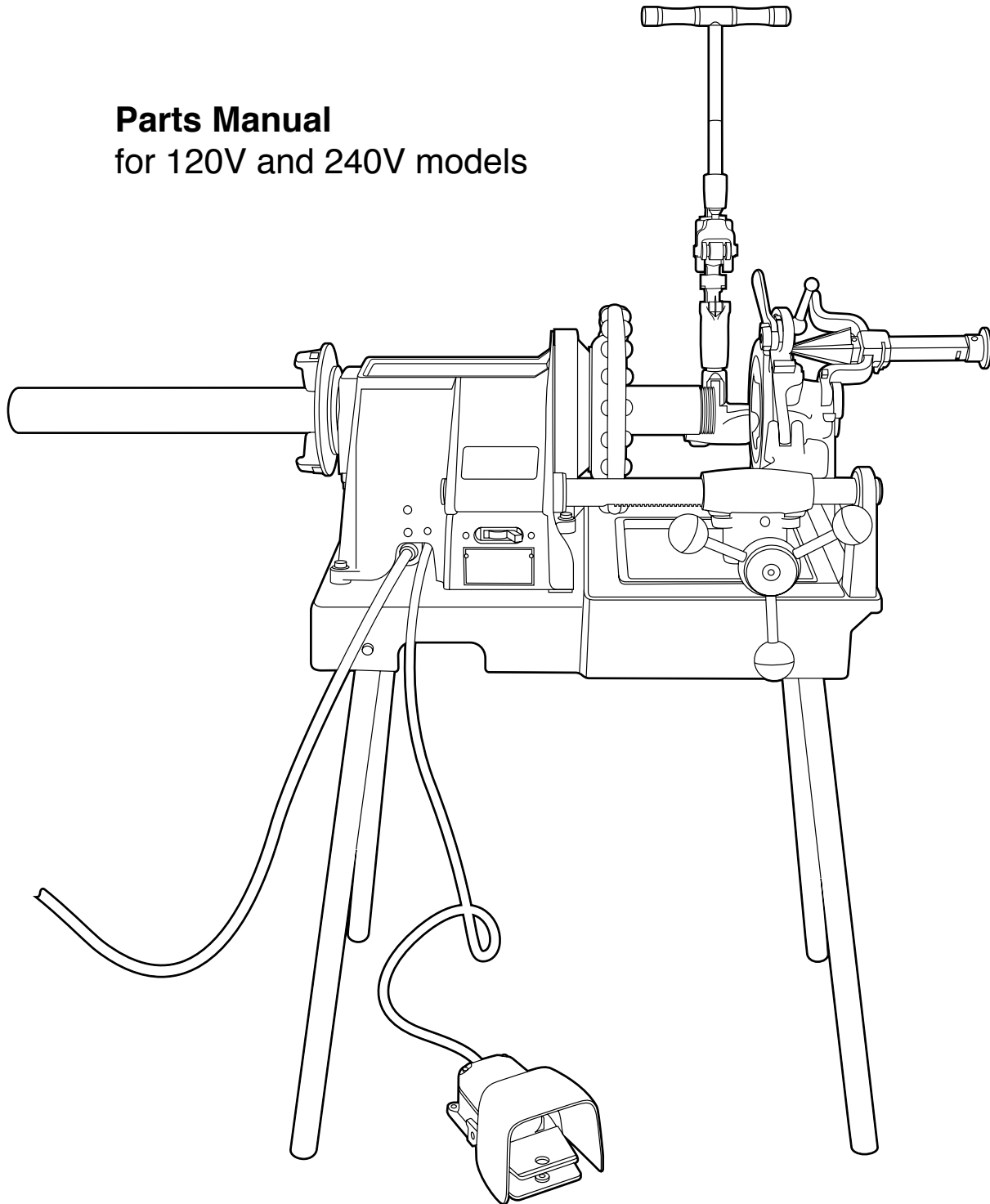

Reed Manufacturing Company  
1425 West 8th Street  
Erie, PA 16502 USA

**QUALITY**  
& Service  
that Last a Lifetime

Phone: 800-666-3691 or 814-452-3691  
Fax: 800-456-1697 or 814-455-1697  
[www.reedmfgco.com](http://www.reedmfgco.com)

# 5401TMSO (120 and 240 Volt) Threading Machine

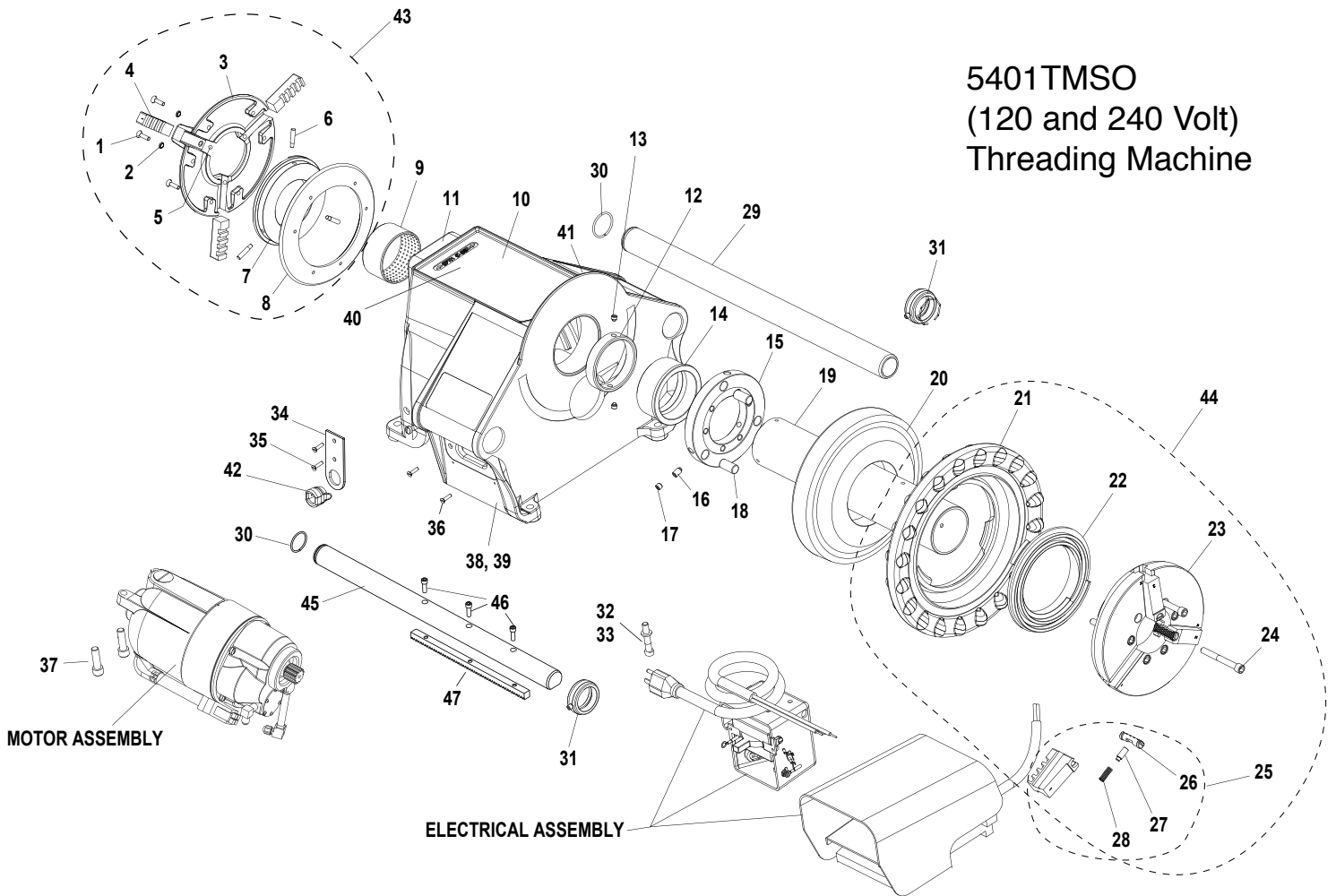

## Parts List

Ref. No.	Description	Item Code	Qty.	Ridgid #
1	SCREW, SLOTTED	35400	6	46790 6/Pk
2	LOCK WASHER	35401	6	40270 6/Pk
3	CENTERING HEAD	95400	1	43735
4	REAR JAW SET	95882	1	46500
5	BALL BEARING	35406	3	—
6	STEP PIN	95411	3	45260 5/Pk
7	SCROLL, REAR	95412	1	44095
8	BACK PLATE	95401	1	43740
9	REAR BEARING	95414	1	—
10	BODY	95571	1	—
11	GREASE FITTING	40338	1	46860
12	THRUST RING	95419	1	45345
13	SET SCREW	35404	2	33785 5/Pk
14	FRONT BEARING	95415	1	—
15	DRIVE RING	95427	1	30027
16	SET SCREW	35412	3	45265 3/Pk
17	SET SCREW	35413	3	45300 5/Pk
18	DRIVE DOWEL PIN	35415	3	30022 3/Pk
19	DRIVE SHAFT	95413	1	44100
20	RING GEAR	95409	1	30017
21	HAND WHEEL	95403	1	89150

Ref. No.	Description	Item Code	Qty.	Ridgid #
22	SCROLL, FRONT	95404	1	43540
23	CAP	95405	1	43525
24	BOLT, SHCS	35405	6	45295 6/Pk
25	JAW SET, FRONT	95552	1	44090
26	JAW INSERT	95421	3	44715
27	PIN	95422	3	—
28	COMPRESSION SPRING	95451	3	—
29	SUPPORT BAR	95397	1	—
30	SPRING RING	95424	2	44525
31	RETAINING RING ASSEMBLY	95880	2	44725
32	LOCK WASHER	35429	1	—
33	BOLT, SHCS	35403	1	—
34	STRAIN RELIEF PLATE	95423	1	45825
35	SCREW	35407	2	44735 5/Pk
36	SCREW	35408	2	45280
37	BOLT, SHCS	35411	2	46745 5/Pk
38	DRIVE SCREW	37710	4	—
39a	NAME PLATE, 120V models	95418	1	—
39b	NAME PLATE, 240V models	95583	1	—
40	WARNING STICKER	95578	1	88690
41	GREASE FITTING	35450	1	—

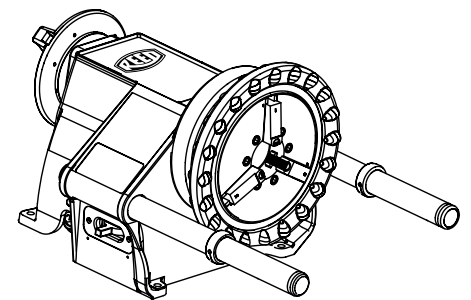

Ref. No.	Description	Item Code	Qty.	Ridgid #
42a	CORD GROMMET, 120V models	95429	1	40736
42b	CORD GROMMET, 240V models	41310	1	—
43	REAR JAW ASSEMBLY	95476	1	—
44	FRONT HANDWHEEL SCROLL / JAW ASSEM.	95484	1	—
45	SUPPORT BAR	95396	1	—
46	BOLT, SHCS	30004	3	—
47	GEAR RACK	95384	1	—

BODY BEARINGS AND HARDWARE INCLUDES:  
9, 10, 11, 14, 39, 40, 41, 45, 46, 95569 1

5401TMSO  
Threading Machine Base

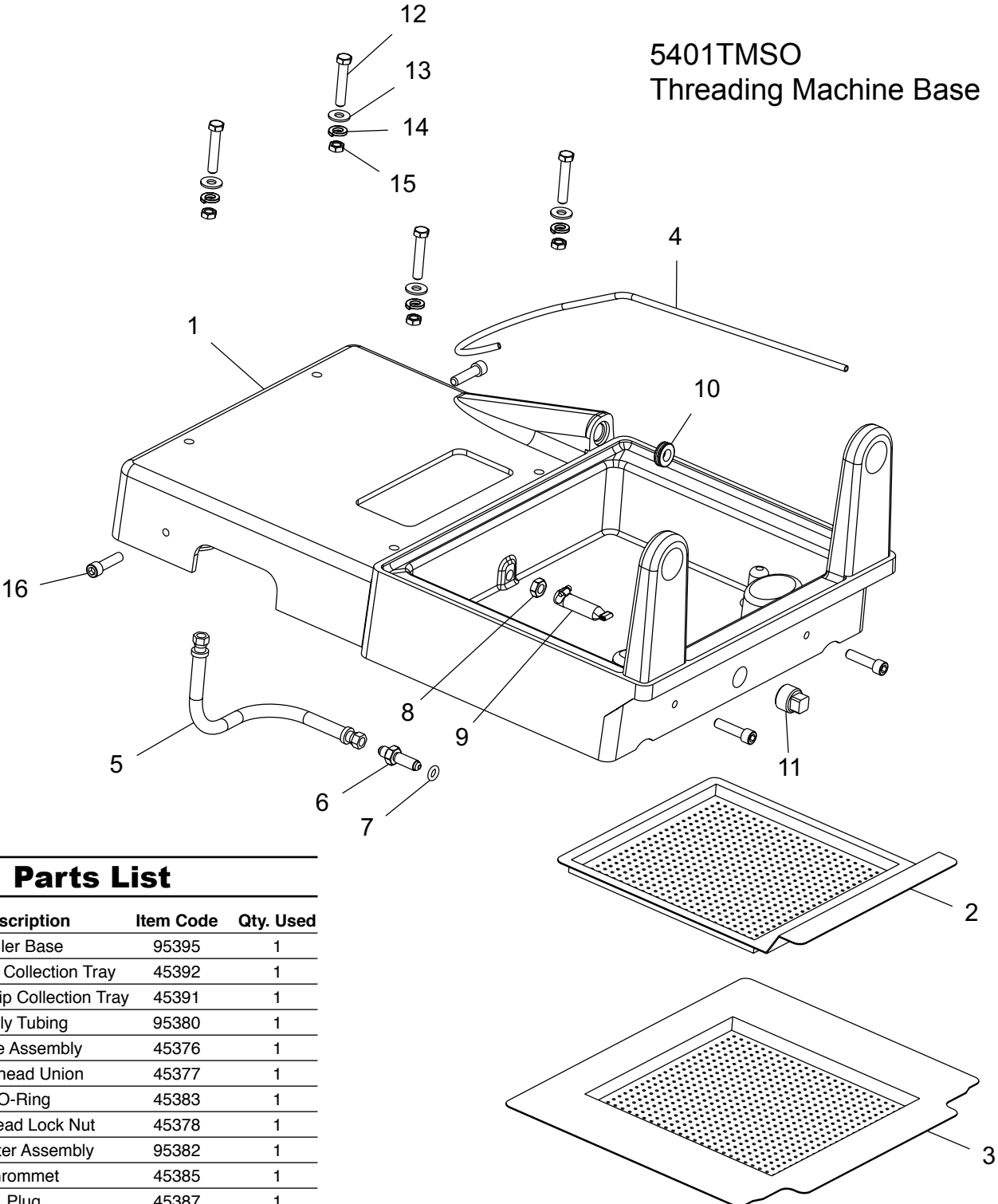

**Parts List**

Ref. No.	Description	Item Code	Qty. Used
1	Oiler Base	95395	1
2	Top Chip Collection Tray	45392	1
3	Bottom Chip Collection Tray	45391	1
4	Poly Tubing	95380	1
5	Hose Assembly	45376	1
6	Bulkhead Union	45377	1
7	O-Ring	45383	1
8	Bulkhead Lock Nut	45378	1
9	Oil Filter Assembly	95382	1
10	Grommet	45385	1
11	Plug	45387	1
12	3/8-16 Bolt	30097	4
13	3/8" Washer	30011	4
14	3/8" Lock Washer	30033	4
15	3/8-16 Nut	39032	4
16	3/8-16X1-1/2 SHCS	30217	4

# 5401TMSO (120 Volt) Motor Assembly

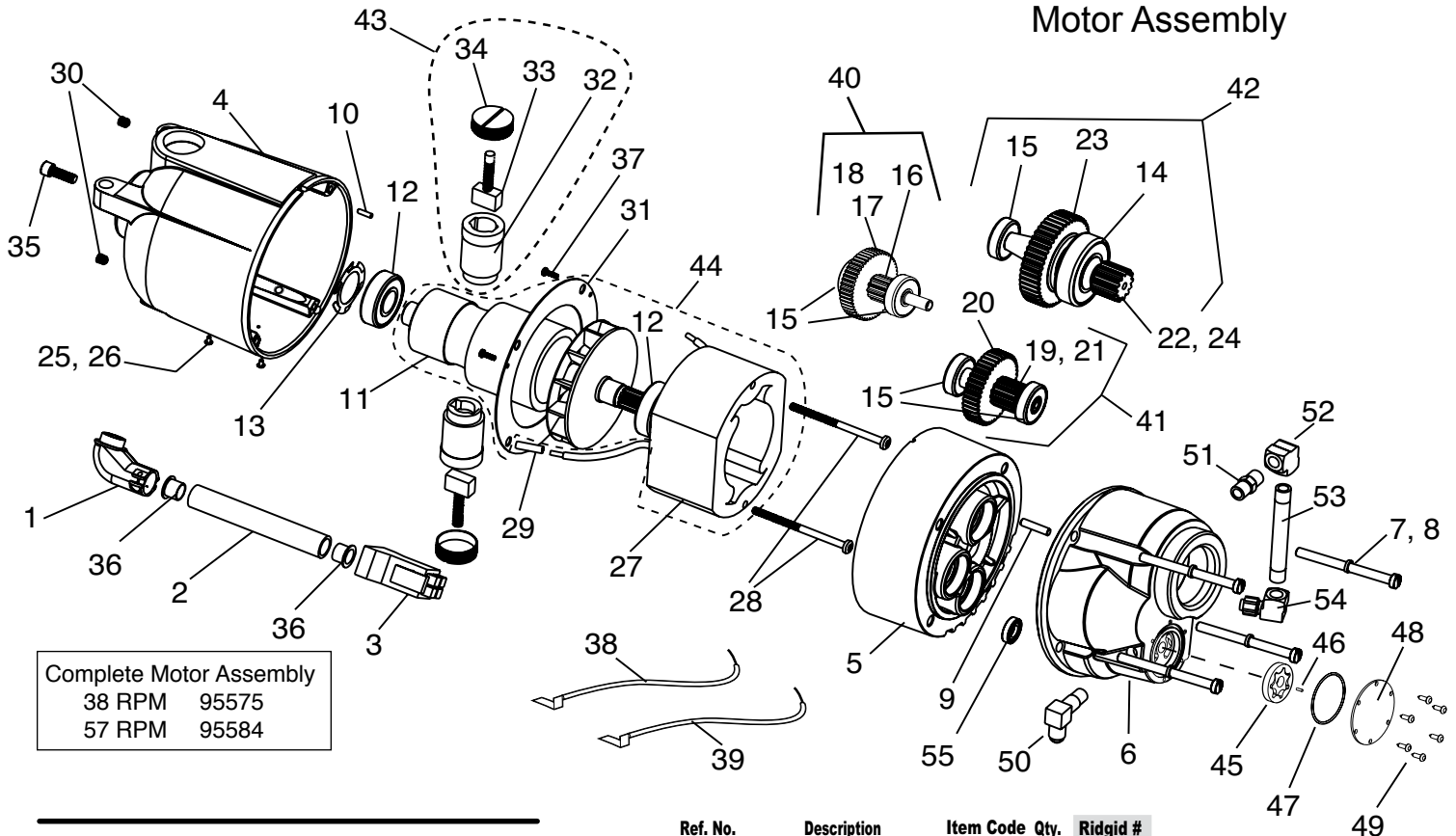

Complete Motor Assembly  
38 RPM 95575  
57 RPM 95584

## Parts List

Ref. No.	Description	Item Code	Qty.	Ridgid #
1	90° CONNECTOR	95452	1	46900
2	CONDUIT	95453	1	—
3	PLUG	95454	1	46830
4	MOTOR HOUSING	95406	1	—
5	FAN HOUSING	95407	1	43165
6	GEAR COVER WITH PUMP CAVITY	95540	1	96830
7	LOCK WASHER	35428	4	45150 5/PK
8	SCREW	35427	4	45075 5/PK
9	DOWEL PIN	95417	1	—
10	DOWEL PIN	35430	1	—
11	ARMATURE W/FAN	95572	1	44010
12	BEARING	98855	2	44565
13	FINGER DISK SPRING	95445	1	44580
14	BEARING	98845	1	45315
15	BEARING	98846	5	45060
16	GEAR SHAFT - 1ST	95595	1	—
17	SPUR GEAR	98809	1	44985
18	KEY	48807	1	44985
19	GEAR SHAFT - 2ND- 38 RPM	95448	1	45005
	- 57 RPM	95564	1	45005
20	SPUR GEAR	95447	1	45005
21	KEY	48810	1	45005
22	GEAR SHAFT - 3RD	95450	1	45370
23	SPUR GEAR - 38 RPM	95449	1	45370
	- 57 RPM	95563	1	45370
24	KEY	48816	1	45370
25	NAME PLATE	95456	1	—
26	DRIVE SCREW	30133	2	85920 5/PK

See Ref. No. 40  
See Ref. No. 41  
See Ref. No. 42

Ref. No.	Description	Item Code	Qty.	Ridgid #
27	FIELD	95573	1	86690 2/Pk
28	FIELD SCREW	98848	2	44555 2/Pk
29	INSULATOR TUBE	98885	2	—
30	SET SCREW	30018	2	39770 5/Pk
31	FAN PLATE	95474	1	—
32	BRUSH HOLDER	95455	2	—
33	BRUSH ASSEMBLY, PAIR	95570	1	44540
34	BRUSH CAP	95459	2	—
35	LOCK SCREW	35435	1	—
36	BUSHING PLASTIC	35434	2	—
37	SCREW	35449	3	—
38	BRUSH LEAD, BLUE w/TERMINAL	95580	1	—
39	BRUSH LEAD, WHITE w/TERMINAL	95579	1	—
40	SHAFT ASSEMBLY 1	95399	1	—
41	SHAFT ASSEMBLY 2 - 38 RPM	95479	1	45005
	57 - RPM	95584	1	—
42	SHAFT ASSEMBLY 3 - 38 RPM	95480	1	45370
	57 RPM	95550	1	—
43	BRUSH/HOLDER/CAP ASSEMBLY	95585	2	—
44	FIELD & ARMATURE	95587	1	—
45	GEROTOR SET	95599	1	96870
46	DOWEL PIN	35596	1	96885
47	O-RING	35595	1	96875
48	PUMP COVER	95591	1	96840
49	SCREWS	35594	6	96890
50	90° LONG ELBOW (JIC/PIPE)	45379	1	—
51	HEX NIPPLE	45375	1	—
52	90° ELBOW	45374	1	—
53	PIPE NIPPLE	45373	1	—
54	90° ELBOW (POLY/PIPE)	45372	1	—
55	OIL SEAL	45596	1	—

See Ref. No. 43

# 5401TMSO (240 Volt) Motor Assembly

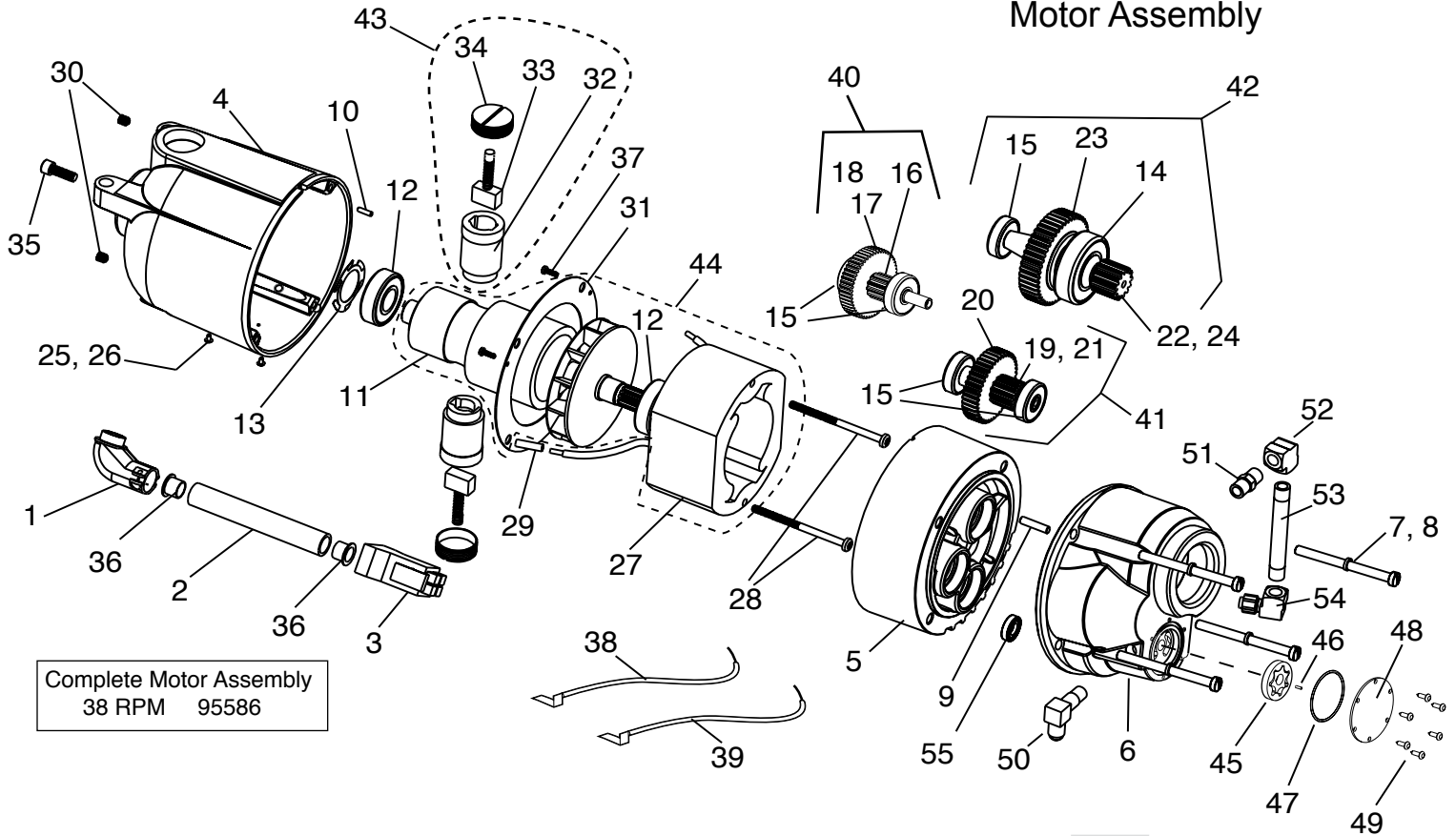

Complete Motor Assembly  
38 RPM 95586

## Parts List

Ref. No.	Description	Item Code	Qty.	Ridgid #
1	90° CONNECTOR	95452	1	46900
2	CONDUIT	95453	1	—
3	PLUG	95454	1	46830
4	MOTOR HOUSING	95406	1	—
5	FAN HOUSING	95407	1	43165
6	GEAR COVER WITH PUMP CAVITY	95540	1	96830
7	LOCK WASHER	35428	4	45150 5/Pk
8	SCREW	35427	4	45075 5/Pk
9	DOWEL PIN	95417	1	—
10	DOWEL PIN	35430	1	—
11	ARAMATURE W/FAN AND BEARINGS	95545	1	—
12	BEARING	98855	2	44565
13	FINGER DISK SPRING	95445	1	44580
14	BEARING	98845	1	45315
15	BEARING	98846	5	45060
16	GEAR SHAFT - 1ST	95595	1	—
17	SPUR GEAR	98809	1	44985
18	KEY	48807	1	44985
19	GEAR SHAFT - 2ND- 38 RPM	95448	1	45005
20	SPUR GEAR	95447	1	45005
21	KEY	48810	1	45005
22	GEAR SHAFT - 3RD	95450	1	45370
23	SPUR GEAR - 38 RPM	95449	1	45370
24	KEY	48816	1	45370
25	NAME PLATE	95582	1	—
26	DRIVE SCREW	30133	2	85920 5/Pk

See  
Ref. No. 40

See  
Ref. No. 41

See  
Ref. No. 42

Ref. No.	Description	Item Code	Qty.	Ridgid #
27	FIELD, 240V	95544	1	—
28	FIELD SCREW	98848	2	44555 2/Pk
29	INSULATOR TUBE	98885	2	—
30	SET SCREW	30018	2	39770 5/Pk
31	FAN PLATE	95474	1	—
32	BRUSH HOLDER	95455	2	—
33	BRUSH ASSEMBLY, PAIR	95542	1	—
34	BRUSH CAP	95459	2	—
35	LOCK SCREW	35435	1	—
36	BUSHING PLASTIC	35434	2	—
37	SCREW	35449	3	—
38	BRUSH LEAD, BLUE w/TERMINAL	95580	1	—
39	BRUSH LEAD, WHITE w/TERMINAL	95579	1	—
40	SHAFT ASSEMBLY 1	95399	1	—
41	SHAFT ASSEMBLY 2 - 38 RPM	95479	1	45005
42	SHAFT ASSEMBLY 3 - 38 RPM	95480	1	45370
43	BRUSH/HOLDER/CAP ASSEMBLIES	95543	1	—
44	FIELD/ARMATURE SET W/BEARINGS	95546	1	—
45	GEROTOR SET	95599	1	96870
46	DOWEL PIN	35596	1	96885
47	O-RING	35595	1	96875
48	PUMP COVER	95591	1	96840
49	SCREWS	35594	6	96890
50	90° LONG ELBOW (JIC/PIPE)	45379	1	—
51	HEX NIPPLE	45375	1	—
52	90° ELBOW	45374	1	—
53	PIPE NIPPLE	45373	1	—
54	90° ELBOW (POLY/PIPE)	45372	1	—
55	OIL SEAL	45596	1	—

See  
Ref. No. 43

RIDGID® is a registered trademark of RIDGID, Inc. and is not associated with Reed Manufacturing Company

**CARRIAGE #05367**  
**5401TMSO Carriage**  
**with Handwheel**

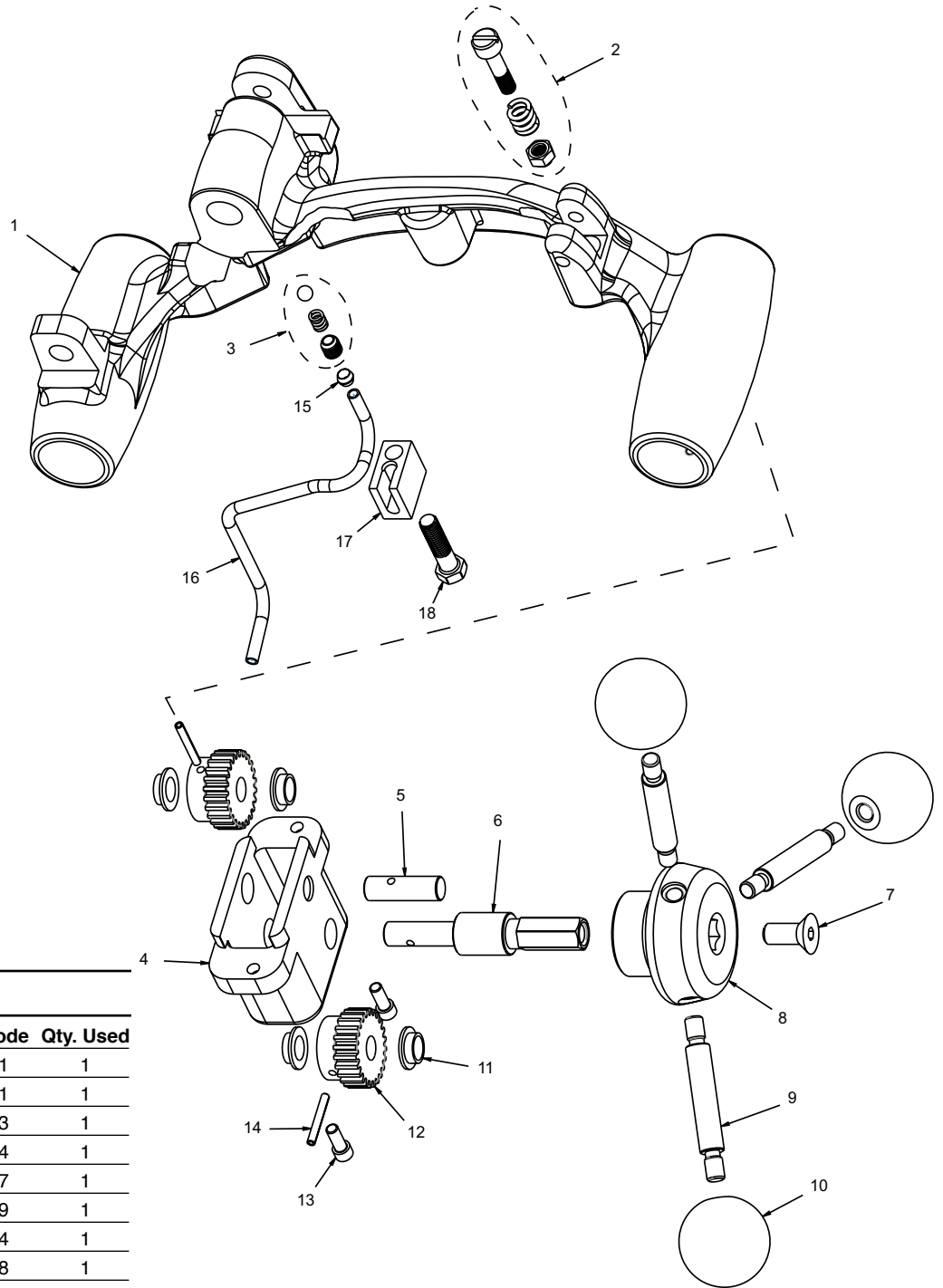

**Parts List**

Ref. No.	Description	Item Code	Qty. Used
1	Carriage Body	95381	1
2	Stop Bolt Assembly	95881	1
3	Ball Retainer Kit	95883	1
4	Handwheel Bracket	95394	1
5	Idler Shaft	95387	1
6	Handwheel Shaft	95389	1
7	Flat Socket Head Cap Screw	35294	1
8	Handwheel Hub	95388	1
9	Handwheel Spoke	95390	3
10	Ball Knob	40054	3
11	Bronze Bushing	40461	4
12	Gear	95386	2
13	1/4-20 X 5/8 SHCS	30105	2
14	Spirol Pin	30233	2
15	1/4" Ferrule	45719	1
16	Bent Tube	45370	1
17	Tube Retainer Block	95590	1
18	3/8-16 X 1-1/2L Bolt	35590	1

5401TMSOCUTTER #05366  
5401TMSO Pipe Cutter

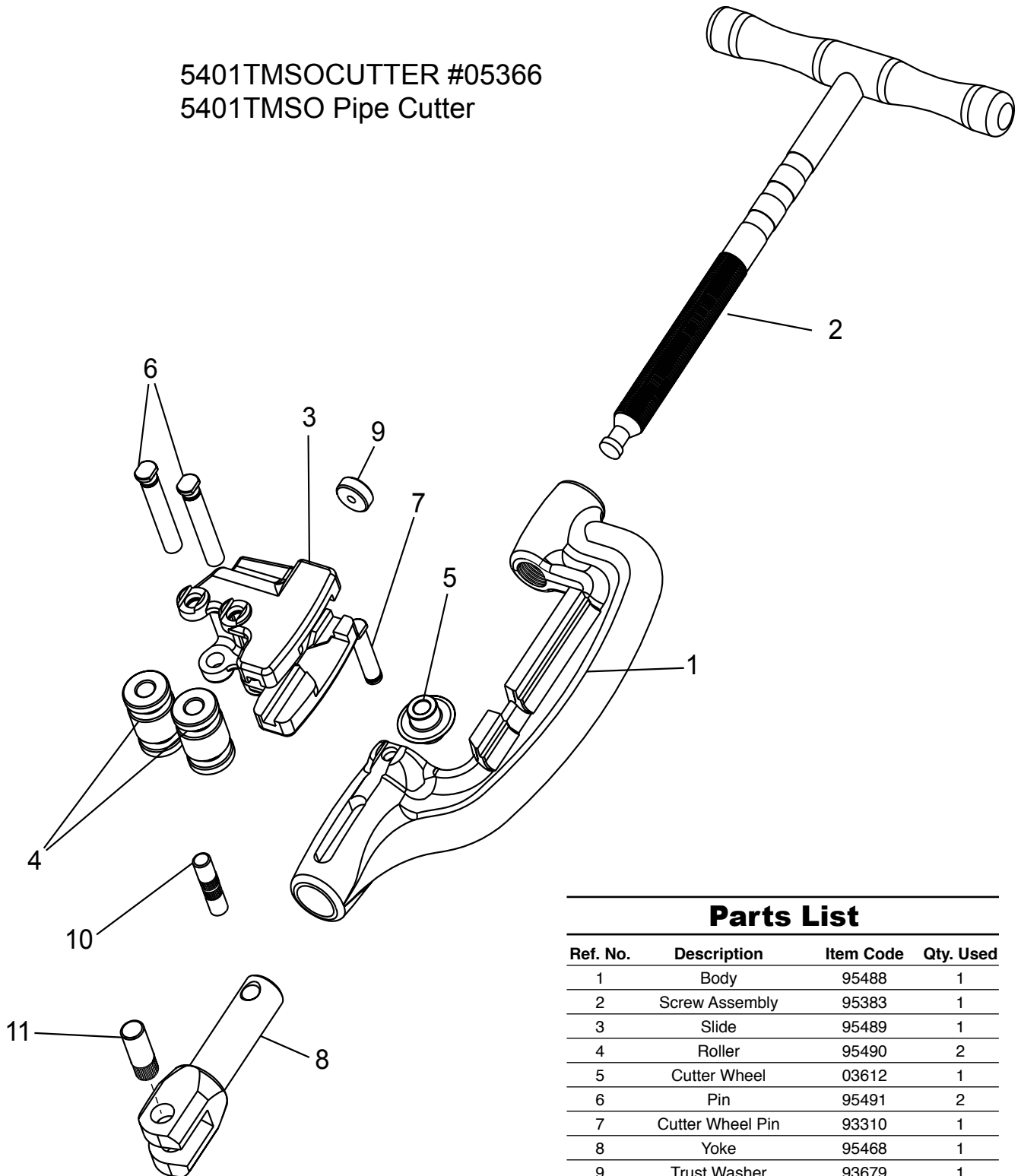

**Parts List**

Ref. No.	Description	Item Code	Qty. Used
1	Body	95488	1
2	Screw Assembly	95383	1
3	Slide	95489	1
4	Roller	95490	2
5	Cutter Wheel	03612	1
6	Pin	95491	2
7	Cutter Wheel Pin	93310	1
8	Yoke	95468	1
9	Trust Washer	93679	1
10	Knurled Pin	95560	1
11	1/2 x 1-1/4 Pin	95561	1

## Reamer #05308

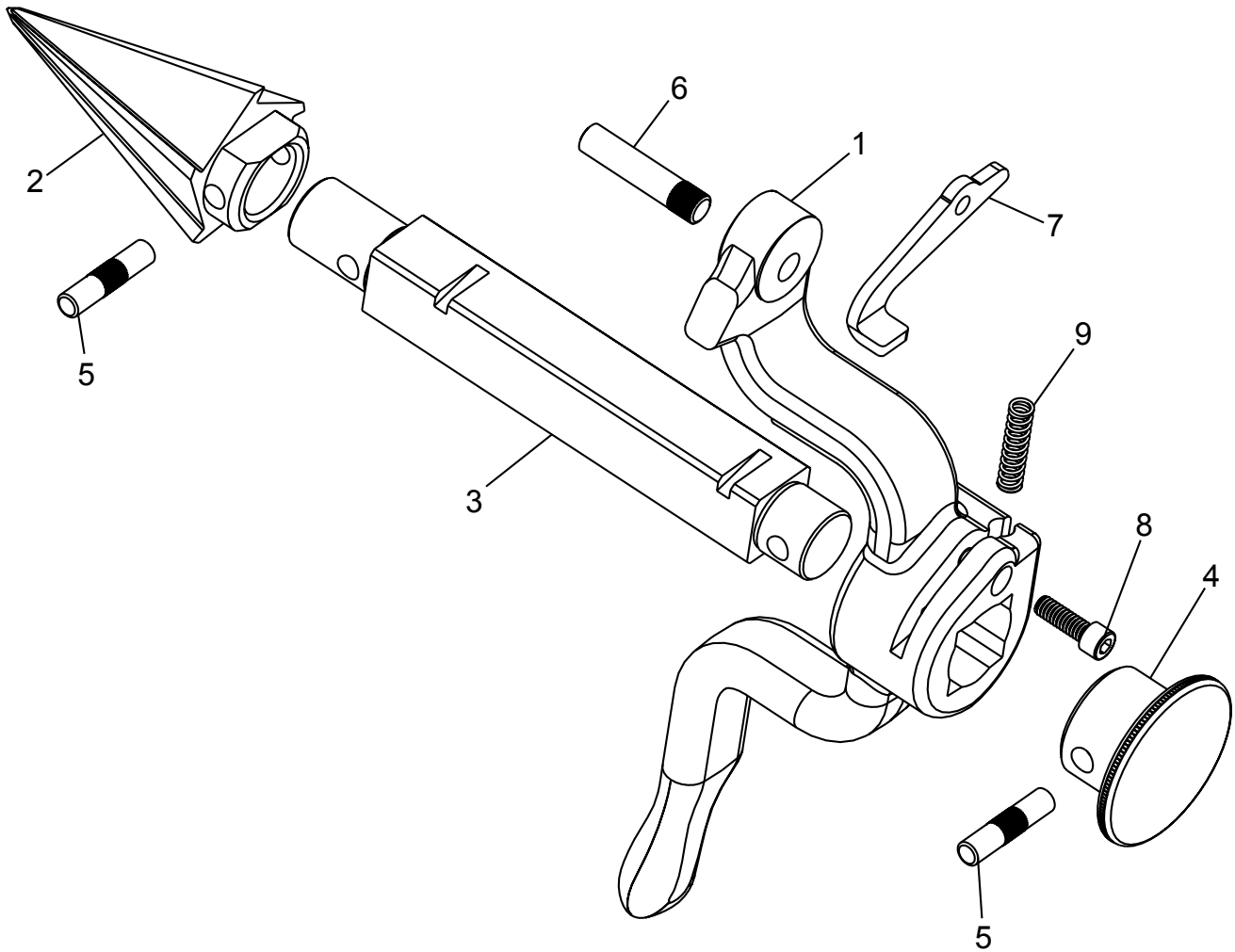

### Parts List

Ref. No.	Description	Item Code	Qty. Used
1	Arm	95487	1
2	Reamer	95492	1
3	Bar	95493	1
4	Knob	95494	1
5	Pin	95495	2
6	Hinge Pin	95496	1
7	Latch	95497	1
8	1/4 x 3/4" Pin	30004	1
9	Spring	95451	1



## 5401TMSO (120 Volt) Electrical Assembly

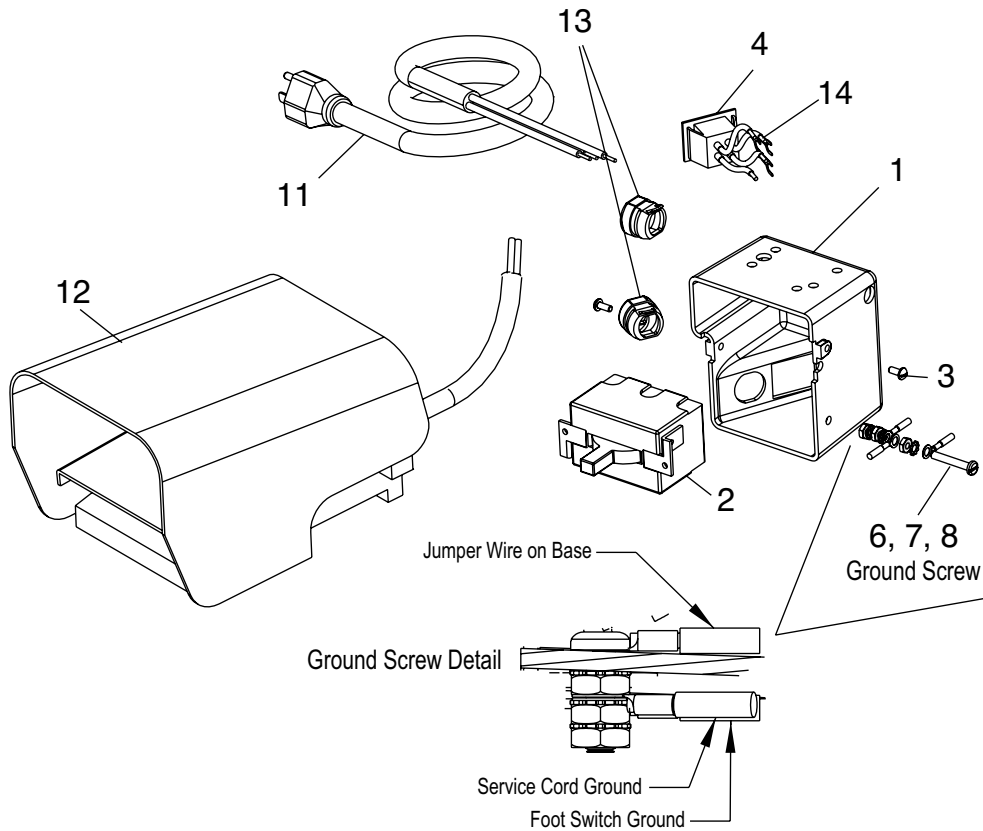

### Parts List

Ref. No.	Description	Item Code	Qty.	Ridgid #
1	SWITCH BOX	95430	1	—
2	SWITCH	95557	1	44505
3	SCREW	30106	2	—
4	OUTLET JUMPER ASSY.	95556	1	—
5	RING TONGUE TERMINAL	98859	3	—
6	SCREW (GROUND)	30159	1	—
7	LOCK WASHER	35423	3	46985 5/Pk
8	HEX NUT	30117	3	—
9	GROUND WIRE	95438	1	—
10	SCREW	35431	1	—
11	LINE CORD W/PLUG	95432	1	46740
12	FOOT SWITCH W/CORD	95574	1	36642
13	CORD GROMMET	95429	3	46735
14	SPADE TERMINAL	35436	4	—

RIDGID® is a registered trademark of RIDGID, Inc. and is not associated with Reed Manufacturing Company

### 5401TMSO (120 Volt) Wiring Schematic

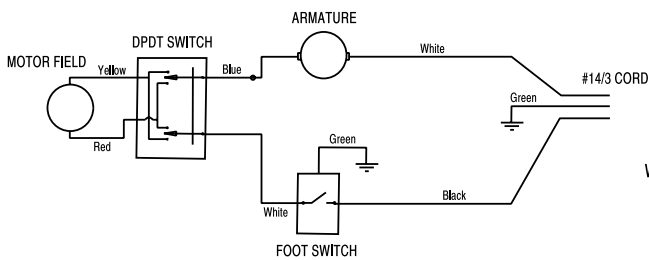

### 5401TMSO (120 Volt) Wiring Diagram

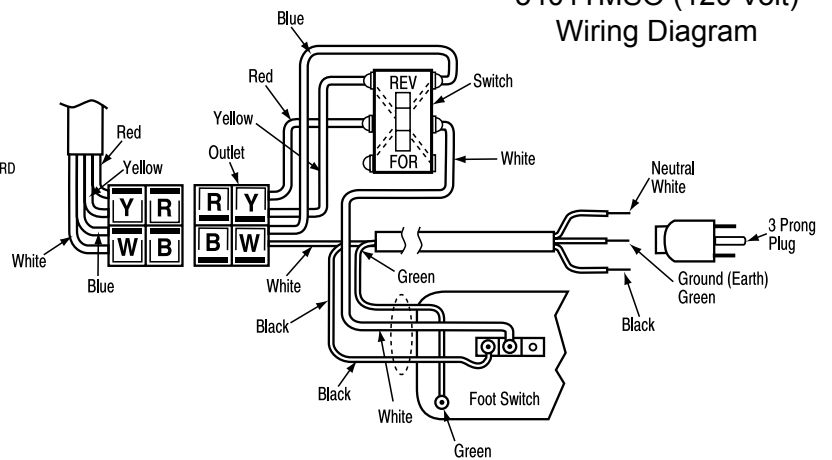

# 5401TMSO (240 Volt) Electrical Assembly

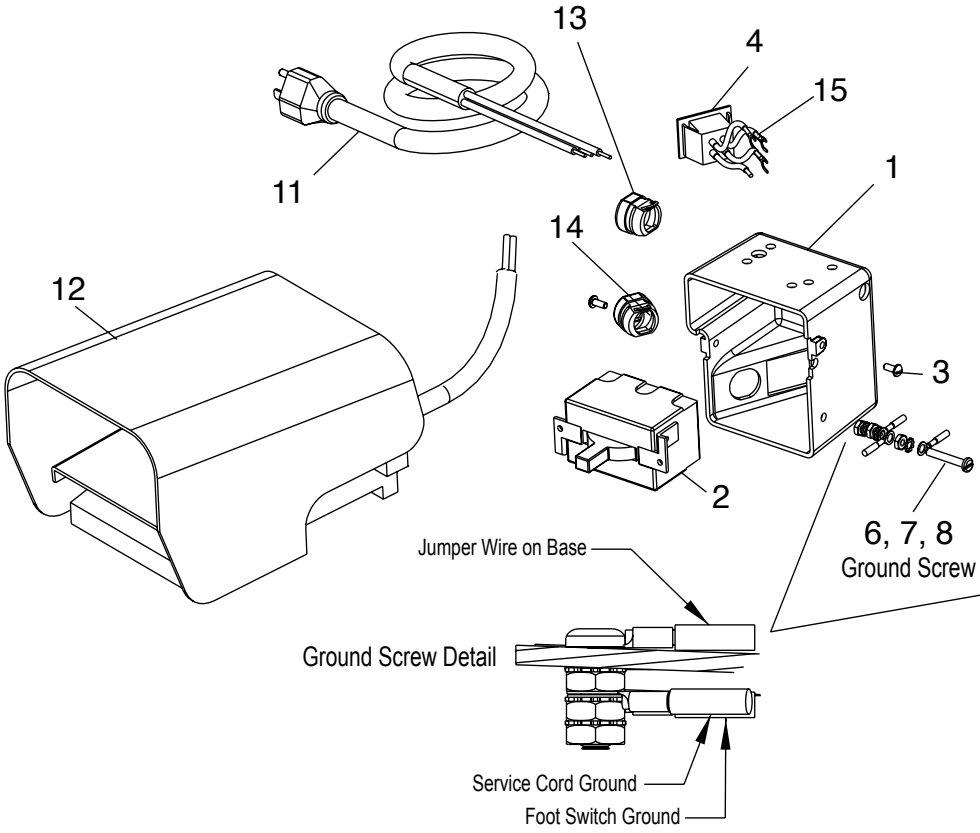

## Parts List

Ref. No.	Description	Item Code	Qty.	Ridgid #
1	SWITCH BOX	95430	1	—
2	SWITCH	95557	1	44505
3	SCREW	30106	2	—
4	OUTLET JUMPER ASSY.	95556	1	—
5	RING TONGUE TERMINAL	98859	3	—
6	SCREW (GROUND)	30159	1	—
7	LOCK WASHER	35423	3	46985 5/Pk
8	HEX NUT	30117	3	—
9	GROUND WIRE	95438	1	—
10	SCREW	35431	1	—
11	LINE CORD W/PLUG	95461	1	—
12	FOOT SWITCH W/CORD	95574	1	36642
13	CORD GROMMET	95429	1	46735
14	CORD GROMMET	41310	1	—
15	SPADE TERMINAL	35436	4	—

RIDGID® is a registered trademark of RIDGID, Inc. and is not associated with Reed Manufacturing Company

5401TMSO (240 Volt)  
Wiring Schematic

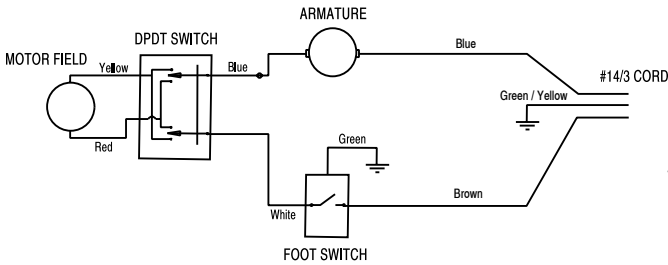

5401TMSO (240 Volt)  
Wiring Diagram

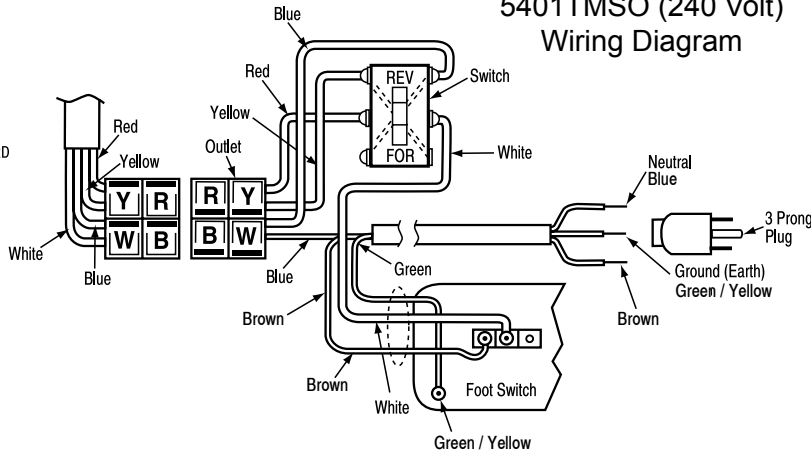

## Reed Lifetime Warranty

Reed Hand Tools are for the professional trade and are warranted against all failure due to defects in workmanship and materials for the normal life of the tool.

FAILURES DUE TO MISUSE, ABUSE, OR NORMAL WEAR AND TEAR ARE NOT COVERED BY THIS WARRANTY.

Power units for Universal Pipe Cutters, Saw It®, electric test pumps, and threading power drives are warranted for a period of one year from date of purchase.

NO PARTY IS AUTHORIZED TO EXTEND ANY OTHER WARRANTY. NO WARRANTY FOR MERCHANTABILITY OR FITNESS FOR A PARTICULAR PURPOSE SHALL APPLY.

No warranty claims will be allowed unless the product in question is received freight prepaid at the Reed factory. All warranty claims are limited to repair or replacement, at the option of the company, at no charge to the customer. REED IS NOT LIABLE FOR ANY DAMAGE OF ANY SORT, INCLUDING INCIDENTAL AND CONSEQUENTIAL DAMAGES. Some states do not allow the exclusion or limitation of incidental or consequential damages, so the above exclusion may not apply.

This warranty gives you specific legal rights, and you may also have other rights which vary from state to state.

