



PIPE TOOLS & VISES
SINCE 1896



CSA
approved for
the United States
and Canada

Catalog No. - 700PD
Item Code #05270

700PD Power Drive

The REED 700PD Power Drive is a portable, electric-motor-driven, heavy-duty power drive which provides power for threading pipe and conduit up to 2" (50 mm) in diameter.

- Automate the pipe threading process
- Dropheads available separately in sizes from 1/2" to 2".

700V Safety Arm (#05275) included



WARNING!

READ AND UNDERSTAND ALL INSTRUCTIONS.
FAILURE TO FOLLOW ALL INSTRUCTION LISTED
INSIDE MAY RESULT IN ELECTRIC SHOCK, FIRE,
AND/OR SERIOUS PERSONAL INJURY.

SAVE THESE INSTRUCTIONS!

REED MANUFACTURING COMPANY
1425 WEST EIGHTH ST. ERIE, PA 16502 USA
PHONE: 800-666-3691 OR 814-452-3691 FAX: 800-456-1697 OR 814-455-1697
www.reedmfgco.com

WORK AREA

1. **Keep your work area clean and well lit. Cluttered benches and dark areas invite accidents.**
2. **Do not operate power tools in explosive atmospheres, such as in the presence of flammable liquids, gases, or dust.** Power tools create sparks which may ignite the dust or fumes.
3. **Keep bystanders, children, and visitors away while operating a power tool.** Distractions can cause you to lose control.

ELECTRICAL SAFETY

1. **Grounded tools must be plugged into an outlet properly installed and grounded in accordance with all codes and ordinances. Never remove the grounding prong or modify the plug in any way. Do not use any adaptor plugs. Check with a qualified electrician if you are in doubt as to whether the outlet is properly grounded.** If the tools should electrically malfunction or breakdown, grounding provides a low resistance path to carry electricity away from the user.
2. **Avoid body contact with grounded surfaces such as pipes, radiators, ranges and refrigerators.** There is an increased risk of electric shock if your body is grounded.
3. **Don't expose power tools to rain or wet conditions.** Water entering a power tool will increase the risk of electric shock.
4. **Do not abuse the cord. Never use the cord to carry the tools or pull the plug from an outlet. Keep cord away from heat, oil, sharp edges or moving parts.** Damaged cords increase the risk of electric shock.
5. **When operating a power tool outside, use an outdoor extension cord marked "W-A" or "W".** These cords are rated for outdoor use and reduce the risk of electric shock.
6. **Use proper extension cords (see chart).** Insufficient conductor size will cause excessive voltage drop, loss of power and overheating.

Minimum Wire Gauge for Cord Set			
Nameplate Amps	TOTAL LENGTH (IN FEET)		
	0 - 25	26 - 50	51 - 100
0 - 6	18 AWG	16 AWG	16 AWG
6 - 10	18 AWG	16 AWG	14 AWG
10 - 12	16 AWG	16 AWG	14 AWG
12 - 16	14 AWG	12 AWG	NOT RECOMMENDED

7. **Connect the tool to an AC power supply that matches the name plate specifications.** Incorrect voltage supply can cause electrical shock or burns.

PERSONAL SAFETY

1. **Stay alert, watch what you are doing and use common sense when operating a power tool. Do not use tool while tired or under the influence of drugs, alcohol, or medication.** A moment of inattention while operating power tools may result in serious personal injury.
2. **Dress properly. Do not wear loose clothing or jewelry. Contain long hair. Keep your hair, clothing and gloves away from moving parts.** Loose clothes, jewelry, or long hair can be caught in moving parts.
3. **Avoid accidental starting. Be sure switch is OFF before plugging in.** Carrying tools with a finger on the switch or plugging in tools that have the switch ON invites accidents.

4. **Remove adjusting keys or switches before turning the tool on.** A wrench or a key that is left attached to a rotating part of the tool may result in personal injury.
5. **Do not overreach. Keep proper footing and balance at all times.** Proper footing and balance enables better control of the tool in unexpected situations.
6. **Use safety equipment. Always wear eye protection.** Dust mask, non-skid safety shoes, hard hat, or hearing protection must be used for appropriate conditions.

TOOL USE AND CARE

1. **Use clamps or other practical methods to secure and support the workpiece to a stable platform.** Holding the work by hand or against your body is unstable and may lead to loss of control.
2. **Do not force the tool. Use the correct tool for your application.** The correct tool will do the job better and safer at the rate for which it is designed.
3. **Do not use the tool if switch does not turn it ON or OFF.** Any tool that cannot be controlled with the switch is dangerous and must be repaired.
4. **Disconnect the plug from the power source before making any adjustments, changing accessories, or storing the tool.** Such preventive safety measures reduce the risk of starting the tool accidentally.
5. **Store idle tools out of reach of children and other untrained persons.** Tools are dangerous in the hands of untrained users.
6. **Maintain tools with care. Keep cutting tools sharp and clean.** Properly maintained tools, with sharp cutting edges are less likely to bind and are easier to control.
7. **Check for misalignment or binding of moving parts, breakage of parts, and any other condition that may affect the tool's operation. If damaged, have the tool serviced before using.** Many accidents are caused by poorly maintained tools.
8. **Use only accessories that are recommended by the manufacturer for your model.** Accessories that may be suitable for one tool may become hazardous when used on another tool.

SERVICE

1. **Tool service must be performed only by qualified repair personnel.** Service or maintenance performed by unqualified personnel could result in a risk of injury.
2. **When servicing a tool, use only identical replacement parts. Follow instructions in the Maintenance section of this manual.** Use of unauthorized parts or failure to follow Maintenance Instructions may create a risk of electric shock or injury.

SPECIFIC SAFETY RULES



The Operator's Manual contains specific safety information and instructions for your protection against serious injuries including:

- Loss of fingers, hands, arms or other body parts if clothing or gloves get caught in moving parts.
- Electrical shock or burns from contact with wires, motor or other power drive parts.
- Impact injuries, including broken bones if machine tips over or workpiece falls.
- Eye injuries, including being blinded by the workpiece or workpiece chips.

Read and follow the safety labels on the machine. Know the location and functions of all controls before using the tool.

Switch Safety

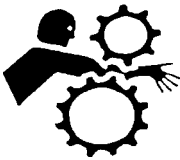
The MOMENTARY CONTACT SWITCH is for your safety. It lets you shut off the motor by removing your finger. If clothing should become caught in the tool, it will continue to wind up. Because this tool has high torque, the clothing itself can bind around your arm or other body parts with enough force to crush or break bones.

 WARNING		
		
<p>WARNING: CLOTHING/GLOVES CAN BE CAUGHT IN MOVING PARTS. FINGERS, HANDS, ARMS OR OTHER BODY PARTS CAN BE CRUSHED OR BROKEN.</p> <ul style="list-style-type: none"> • Do not wear gloves. • Keep sleeves and jackets buttoned. • Keep switch in working order. • Use safety arm when threading. • Do not carry plugged-in tool with finger on switch. 		

TOOL SAFETY

1. The **POWER DRIVE** is made to thread pipe. Follow instructions in this Operator's Manual on tool use. Other uses may increase the risk of injury.
2. **ALWAYS** secure **POWER DRIVE** using the provided **700V safety arm (#05275)**. Do not use this **POWER DRIVE** without the provided safety arm. The safety arm resists torque developed during threading and prevents losing control of the tool.
3. Do not use dull or damaged dies. Sharp cutting tools are less likely to bind and tool is easier to control
4. Do not use if **MOMENTARY CONTACT SWITCH** is broken. The purpose of the switch is to prevent injuries.

FUNCTIONAL DESCRIPTION

The REED 700PD Power Drive is an electric-motor-driven, heavy-duty power drive which provides power for threading pipe and conduit up to 2" in diameter. The 700PD is NOT designed to turn geared threaders, tapping machines, or other equipment.

SPECIFICATIONS / STANDARD EQUIPMENT

Threading Capacity

Pipe and Conduit: 1/8" through 2" right hand threads only.

Motor, Gears, Speed

- 120 Volts, AC (50 - 60 Hz), 1/2 horsepower, double insulated.
- Momentary contact switch, spring return to OFF position.
- Mechanical forward/reverse switch: 25 RPM.
- Spur gear reduction, bearing mounted shafts, gears packed in grease.
- Spring-loaded adapter pawls.
- Gear case is cast aluminum. Motor housing and handle are cast aluminum.
- Safety Arm is ductile iron and steel.
- Machine weight: 31.4 lbs (14.3 Kg).
- Safety Arm weight: 10.5 lbs (4.8 Kg).
- The 700V safety arm (standard) is necessary for operation to absorb power drive torque.

OPERATION

For threading with drophead die heads only, such as Reed R12+ Dropheads with R12+ Segmental Dies.

WARNING: OPERATOR SHOULD BE THOROUGHLY FAMILIAR WITH SAFETY INFORMATION BEFORE ATTEMPTING TO OPERATE THIS EQUIPMENT.

1. Push die heads, small end first, squarely into power drive opening until spring-loaded adapter pawls catch securely.

NOTE: Installation can be on either side of face gear.

2. Secure pipe in portable tripod or bench vise, if available.

WARNING: WHEN THREADING ANY SIZE PIPE, THE SUPPLIED 700V SAFETY ARM SHOULD ALWAYS BE USED AND SECURELY LOCKED ON PIPE BECAUSE OF TORQUE DEVELOPED DURING THREADING.

3. Ensure at least 6" (150 mm) of exposed pipe end. Position 700V safety arm between 4" (100 mm) and 7" (180 mm) from the end of the pipe so the end of the guide bar is 1" (25 mm) to 4" (100 mm) beyond the end of the pipe. Clamp the safety arm securely onto the pipe. When threading 1 1/2" and 2" pipe, it is best to place the safety arm just 4" (100 mm) from the end of the pipe for firmest control of higher torque.
4. Place die head over end of pipe. Make sure power drive is correctly positioned on support arm. For right hand threads, die head should rotate clockwise (looking at face of die head).

NOTE: During threading, apply plenty of REED Threadguard cutting oil to dies.

5. Simultaneously actuate switch button and exert pressure against die head with palm of free hand to make sure thread is started.
6. Keep switch button depressed until end of pipe is even with edge of chaser, then release switch button.

WARNING: HOLD ON TO POWER DRIVE HANDLE FIRMLY TO RESIST INITIAL TORQUE WHILE BACKING OFF DIE HEAD.

7. After completion of the thread, and after the motor has stopped, actuate the switch in the reverse direction.
8. When dies clear the end of the pipe, grip handle on top of the power drive and remove the power drive from the pipe. Release the safety arm and remove it as well.

MAINTENANCE

WARNING: ALWAYS UNPLUG POWER CORD BEFORE SERVICING POWER DRIVE.

NOTE: If any maintenance is required other than brush replacement, take power drive to an authorized REED warranty repair center or return to factory.

Motor Brush Replacement

Check motor brushes every 6 months or 250 working hours and replace the brushes when worn to less than 1/4" (5 mm). Harsh environmental conditions could warrant more frequent checks. When checking the brushes for wear, also clean the brush holders with a clean rag.

Lubrication

Gearing has been greased at the factory and does not require additional grease. It is best to blow dust off the machine after work is over.

R12+ HSS Segmental Dies & Dropheads

R12+ SEGMENTAL DIES

Cat. No.	Item Code	Size	Std. Pkg.
R12DNPVC1/2	05560	1/2" PVC	4
R12DNPVC3/4	05561	3/4" PVC	4
R12DNPVC1	05562	1" PVC	4
R12DNPVC1 1/4	05563	1 1/4" PVC	4
R12DNPVC1 1/2	05564	1 1/2" PVC	4
R12DNPVC2	05565	2" PVC	4
R12DN1/2	05606	1/2" NPT	4
R12DN3/4	05608	3/4" NPT	4
R12DN1	05610	1" NPT	4
R12DN1 1/4	05612	1 1/4" NPT	4
R12DN1 1/2	05614	1 1/2" NPT	4
R12DN2	05616	2" NPT	4
R12DNBSPT1/2	05643	1/2" BSPT	4
R12DNBSPT3/4	05644	3/4" BSPT	4
R12DNBSPT1	05645	1" BSPT	4
R12DNBSPT1 1/4	05646	1 1/4" BSPT	4
R12DNBSPT1 1/2	05647	1 1/2" BSPT	4
R12DNBSPT2	05648	2" BSPT	4
R12DNPSM1/2	05680	1/2" NPSM	4
R12DNPSM3/4	05681	3/4" NPSM	4
R12DNPSM1	05682	1" NPSM	4
R12DNPSM1 1/4	05683	1 1/4" NPSM	4
R12DNPSM1 1/2	05684	1 1/2" NPSM	4
R12DNPSM2	05685	2" NPSM	4

R12+ DROPHEADS

Cat. No.	Item Code	Size
DHR121/2PVC	05568	1/2" PVC (NPT)
DHR12 3/4PVC	05569	3/4" PVC (NPT)
DHR121PVC	05570	1" PVC (NPT)
DHR121 1/4PVC	05571	1 1/4" PVC (NPT)
DHR121 1/2PVC	05572	1 1/2" PVC (NPT)
DHR12 2PVC	05573	2" PVC (NPT)
DHR12 3/4BSPT	05594	3/4" BSPT
DHR121BSPT	05595	1" BSPT
DHR121 1/4BSPT	05596	1 1/4" BSPT
DHR121 1/2 BSPT	05597	1 1/2" BSPT
DHR12 2BSPT	05598	2" BSPT
DHR121/2NPT	05626	1/2" NPT
DHR123/4NPT	05628	3/4" NPT
DHR121NPT	05630	1" NPT
DHR121 1/4NPT	05632	1 1/4" NPT
DHR121 1/2NPT	05634	1 1/2" NPT
DHR122NPT	05636	2" NPT
DHR121/2NPSM	05690	1/2" NPSM
DHR123/4NPSM	05691	3/4" NPSM
DHR12 NPSM	05692	1" NPSM
DHR121 1/4NPSM	05693	1 1/4" NPSM
DHR121 1/2NPSM	05694	1 1/2" NPSM
DHR122NPSM	05695	2" NPSM

R12+ THREADER SETS

Find R12+ Threader Sets in the Reed catalog or www.reedmfco.com.

Wiring Diagram (115/230V)

Standard Color Code

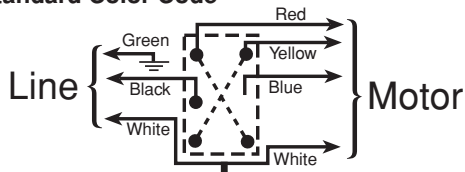

European Color Code

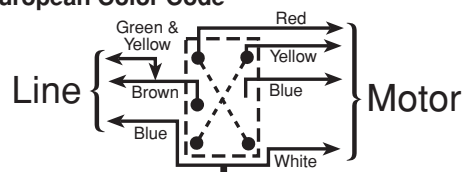

Fig. 1 700PD



Fig. 2 Inserting R12+ Drophead

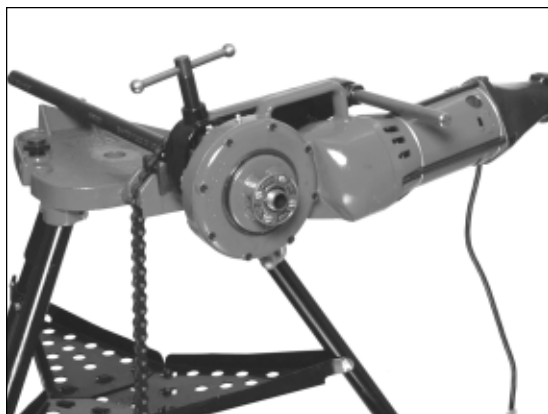

Fig. 3 Set Up for Threading

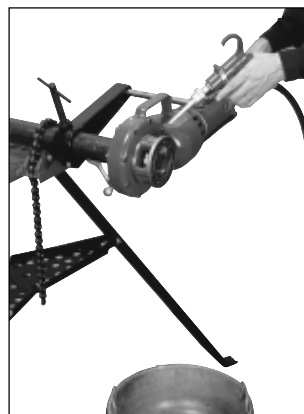

Fig. 4 Threading 2" Pipe

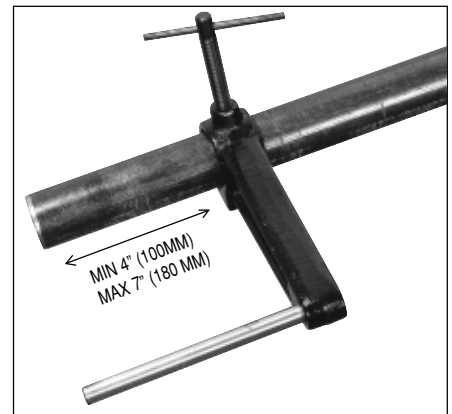
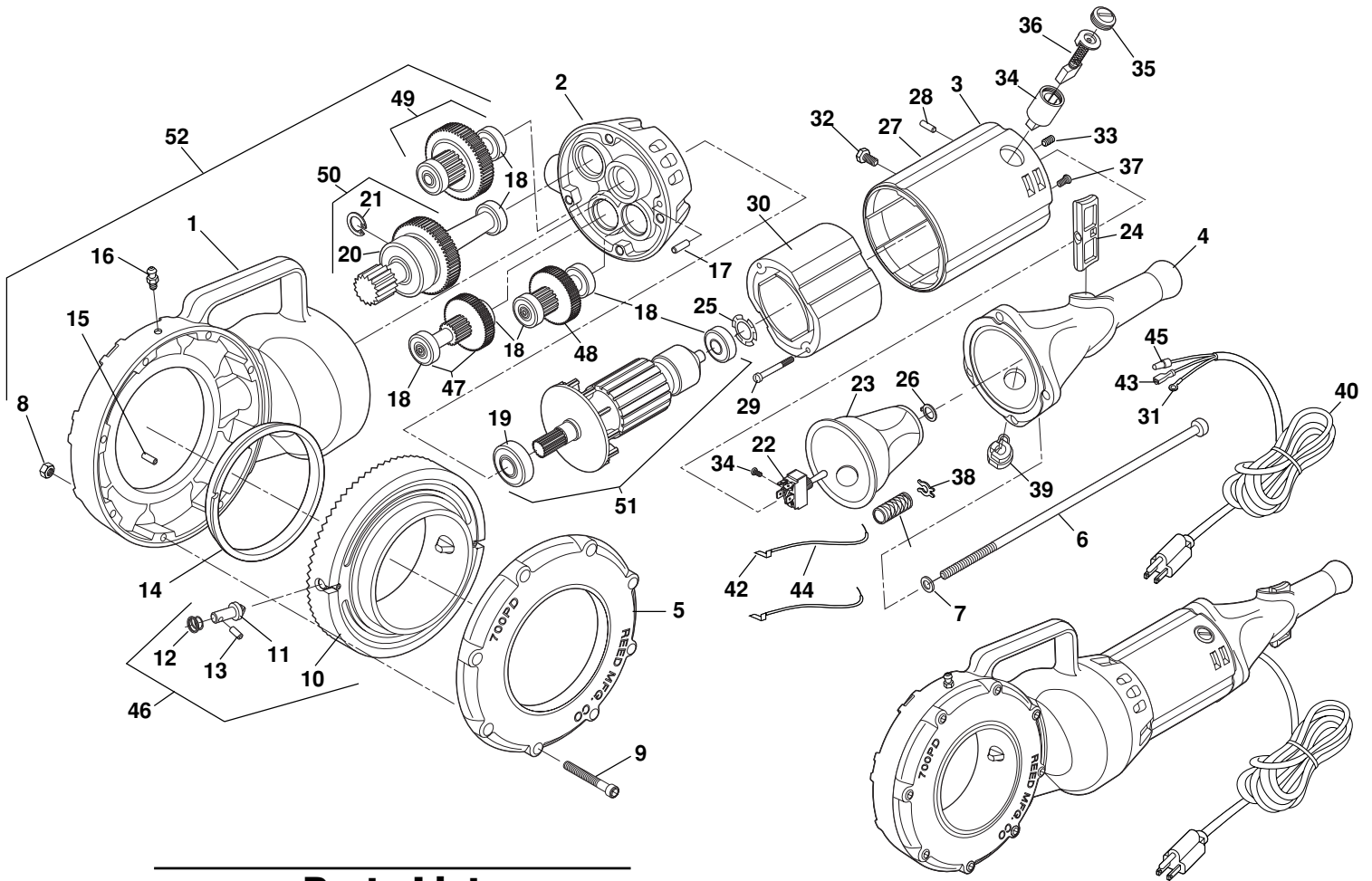

Fig. 5 Safety Arm Position

700PD



Parts List

Ref. No.	Description	Item Code	Qty. Used
1	Gear Case	98800	1
2	Fan Housing	98801	1
3	Motor Housing	98802	1
4	Handle	98803	1
5	Coverplate	98804	1
6	Tie Bolt	98830	4
7	Lock Washer	30049	4
8	Lock Nut	30108	8
9	Socket Head Cap Screw	38838	8
10	Facegear	98805	1
11	Adaptor Pawl	98837	2
12	Pawl Spring	98836	2
13	Pawl Spring Pin	38835	2
14	Face Bearing	98806	1
15	Face Bag Spring Pin	38857	1
16	Grease Fitting	40338	2
17	Dowel Pin	48847	1
18	Bearing	98846	7
19	Bearing	98855	1
20	Bearing	98845	1
21	Retaining Ring	38856	1
22	Switch Assembly	98872	1
23	Switch Insulator	98878	1
24	Switch Button	98849	1
25	Finger Disk Spring	98858	1
26	Lock Ring	38875	1

Ref. No.	Description	Item Code	Qty. Used
27	Name Plate	98833	1
28	Fastener, Drive Pin	30133	2
29	Field Screw	98848	2
30	Field	98825	1
31	Ring Tongue Terminal	98859	1
32	Lock Screw	38865	1
33	Set Screw	30018	2
34	Brush Holder, Pack of 2	98897	1
35	Brush Cap, Pack of 2	98898	1
36	Brush Assembly, Pack of 2	98899	1
37	Ground Screw	38870	1
38	X Washer	99010	2
39	Cord Retainer	98883	1
40	Cord	98882	1
41	Insulator Tube	98885	1
42	Terminal Flag, Brush	98877	2
43	Terminal	98860	4
44	Wire	38879	1
45	Wire Nut	98880	1
46	Face Gear Assembly	98902	1
47	Gear Shaft Assembly 1	98903	1
48	Gear Shaft Assembly 2	98904	1
49	Gear Shaft Assembly 3	98905	1
50	Gear Shaft Assembly 4	98906	1
51	Armature Assembly	98908	1
52	Gear Case Assembly	98901	1



Reed Lifetime Warranty

Reed Hand Tools are for the professional trade and are warranted against all failure due to defects in workmanship and materials for the normal life of the tool.

FAILURES DUE TO MISUSE, ABUSE, OR NORMAL WEAR AND TEAR ARE NOT COVERED BY THIS WARRANTY.

Power units for Universal Pipe Cutters and threading power drives are warranted for a period of one year from date purchased.

NO PARTY IS AUTHORIZED TO EXTEND ANY OTHER WARRANTY. NO WARRANTY FOR MERCHANTABILITY OR FITNESS FOR A PARTICULAR PURPOSE SHALL APPLY.

No warranty claims will be allowed unless the product in question is received freight prepaid at the Reed factory. All warranty claims are limited to repair or replacement, at the option of the company, at no charge to the customer. REED IS NOT LIABLE FOR ANY DAMAGE OF ANY SORT, INCLUDING INCIDENTAL AND CONSEQUENTIAL DAMAGES. Some states do not allow the exclusion or limitation of incidental or consequential damages, so the above exclusion may not apply.

This warranty gives you specific legal rights, and you may also have other rights which vary from state to state.



PIPE TOOLS & VISES
SINCE 1896

REED MANUFACTURING COMPANY

1425 WEST EIGHTH ST. ERIE, PA 16502 USA

PHONE: 800-666-3691 OR 814-452-3691 FAX: 800-456-1697 OR 814-455-1697

www.reedmfgco.com